

**SHEAR STRENGTH AND SHEAR STIFFNESS OF
PERMANENT STEEL BRIDGE DECK FORMS**

By

**Robert M. Currah
Karl H. Frank**

**with support from
American Iron & Steel Institute
Texas Department of Transportation
and
Federal Highway Administration**

ACKNOWLEDGEMENTS

This research program was conducted at the Phil M. Ferguson Structural Engineering Laboratory located at the Balcones Research Center of The University of Texas at Austin. Funding for this research project was provided by the American Iron and Steel Institute, the Texas Department of Transportation and the Federal Highway Administration. In addition, deck materials were donated by Buffalo Specialty Products, Inc. and Bowman Metal Deck. Their assistance in this program is greatly appreciated.

The authors wish to thank Professor Michael D. Engelhardt for his invaluable input on this project.

It has been a particular pleasure to have worked with Todd Helwig over the past two years. Todd was responsible for the design of the test frame and the establishment of the test program. Together, we constructed the test frame and conducted many of the initial deck tests. He has worked extensively on the project from its inception and deserves much of the credit for the successful completion of this report. We wish Todd the best in the completion of the deck study and everything he tackles in the future. Thanks also to Erik Soderberg for conducting the tension tests and good luck with the support study.

The help of the technicians, faculty, staff and fellow students is also greatly appreciated. The professional and friendly atmosphere at Ferguson Lab provides a great place for students to work and learn. Thanks to April, Laurie, Blake, Wayne², Pat, Ryan and Ray for all the assistance so willingly extended. Special thanks to Sharon Cunningham for her guidance during the writing of this report.

ABSTRACT

SHEAR STRENGTH AND SHEAR STIFFNESS OF PERMANENT STEEL BRIDGE DECK FORMS

by

ROBERT MITCHELL CURRAH, B.S.
SUPERVISING PROFESSOR: KARL H. FRANK

The behavior of several types of Permanent Steel Bridge Deck Forms was studied. The tests were conducted on full scale deck panels typically 8 feet wide with deck spans ranging from approximately 7½ feet to 13 feet. Loading was applied through a test frame in order to impart a shear deflection to the deck panels. The objective of this study was to examine the shear strength and shear stiffness of the deck forms included in the test program.

It is common practice to support bridge deck forms on support angles attached to the bridge girders to allow for elevation adjustment of the deck forms during erection of the steel bridge deck. The majority of the tests in this study were conducted using a rigid deck support member attached to the test frame. The results of these tests provided strength and stiffness capacities of the deck forms without any effect due to the flexibility of the deck support angle. Several additional tests were performed with the deck panels supported on support angles similar to those used in the industry today. These tests provided a preliminary indication of the effect that these support methods have on the shear strength and shear stiffness of the girder/deck form system.

Test results were compared to strength and stiffness values predicted by the Steel Deck Institute (SDI) Design Manual to determine if this design manual could be used to estimate the shear capacities of Permanent Steel Bridge Deck Forms. The SDI design equations were found to provide acceptable shear strength and shear stiffness values for certain types of Permanent Steel Bridge Deck Forms but not for all types. The results of these comparisons are presented in this report.

TABLE OF CONTENTS

CHAPTER 1 INTRODUCTION	1
1.1 Background	1
1.2 Objective of Study	1
1.3 Shear Diaphragms	3
1.3.1 Building Applications.	3
1.3.2 Potential Bridge Applications.	5
1.4 Diaphragm Strength	6
1.5 Failure Modes	7
1.5.1 Failure of an End Fastener.	8
1.5.2 Failure of a Seam Fastener.	8
1.5.3 Bearing Deformation at End Fasteners - Parallel to Span.	8
1.5.4 Bearing Deformation at End Fasteners - Perp. to Span.	9
1.5.5 Deck Bearing Deformation at a Seam Fastener.	9
1.5.6 Overall Shear Buckling of Deck Panel.	9
1.5.7 Failure of the Deck Support Angle.	9
1.6 Diaphragm Shear Stiffness	9
1.7 Deck Fasteners	10
1.8 Standard Deck Support Angle Configurations	10
CHAPTER 2 PERMANENT METAL DECK FORM TYPES	13
2.1 Overview	13
2.2 Open Deck	16
2.3 Flat Soffit Deck Forms	16
2.4 Deck Panel Test Widths	17
2.5 Deck Strength Properties	17
CHAPTER 3 TEST APPARATUS & PROCEDURE	21
3.1 Overview	21
3.2 Test Frame	21
3.3 Instrumentation	24
3.4 Deck Attachment	24
3.4.1 Rigid Connection.	24
3.4.2 Welded Angle Eccentric Connection	25
3.4.3 Strap Angle Eccentric Connection	25
3.5 Test Procedure	26
3.6 Frame Friction Tests	29
CHAPTER 4 TEST RESULTS	31
4.1 Overview	31
4.1.1 Unloaded Shear Stiffness	31
4.1.2 Loaded Shear Stiffness	32
4.1.3 Deck Panel Shear Strength.	34
4.1.4 Ductility of Failure	34
4.1.5 Midspan Deck Deflections	34

4.2 Deck Tests Results	35
4.2.1 Standard and Fully Fastened Configurations	35
4.2.2 Standard/Full Fastener Combinations.	43
4.2.3 8' Wide Panel - Missing Fasteners	43
4.2.4 12' Wide Panel.	45
4.2.5 Support Angle Configurations	46
4.2.6 Powder-Actuated Fasteners	48
4.3 Modes of Failure	49
4.3.1 Failure of an End Fastener	49
4.3.2 Substantial Deck Bearing Deformation	49
4.3.3 Deck Support Angle Failures.	50
4.3.4 Powder-Actuated Fastener Failures	50
CHAPTER 5 ANALYSIS & COMPARISON OF RESULTS	53
5.1 Overview	53
5.2 Effect of Fastener Spacings on Shear Stiffness	53
5.3 Experimental Shear Stiffness Values	55
5.3.1 Open Profile Stiffness Values	56
5.3.2 Flat Soffit (LSM) Profile Stiffness Values	57
5.3.3 Recommended Design Shear Stiffness.	58
5.4 Experimental Shear Strength Values	59
5.5 Non-Rigid Support Configuration Considerations	59
5.5.1 Estimation of Support Connection Stiffness	60
5.6 Effect of Overall Panel Width	61
5.6.1 Deck Panel with Rigid Connection.	61
5.6.2 Deck Panel with Welded Eccentric Angle Connection.	62
5.7 Powder-Actuated Pins at End Fasteners	63
5.8 Design Manual Stiffness and Strength	63
5.8.1 SDI Design Stiffness vs. Measured Stiffness	63
5.8.2 SDI Design Strength vs. Measured Strength.	67
CHAPTER 6 SUMMARY AND CONCLUSIONS	71
6.1 Stiffness and Strength Capacities	71
6.1.1 Recommended Fastener Configurations	71
6.1.2 Experimental Shear Stiffness & Shear Strength Values	72
6.2 Support Angle Considerations	72
6.3 Estimation of Stiffness and Strength	73
APPENDIX A	75
BIBLIOGRAPHY	85

LIST OF TABLES

Table 2.1	Open profile decks included in test program.	16
Table 2.2	Flat soffit decks included in test program.	17
Table 2.3	Experimental and ASTM deck properties.	19
Table 4.1	Test results for 8' wide panels with standard and fully fastened configurations.	36
Table 4.2	Test results for combinations of standard and fully fastened configurations.	44
Table 4.3	Test results for 8' wide panel with missing side lap fasteners.	45
Table 4.4	Test results for 8' wide panel with missing end fasteners.	45
Table 4.5	Test results for 12' wide panel with missing side lap fasteners.	47
Table 4.6	Comparison of rigid support tests with eccentric support tests - 8' wide panels.	47
Table 4.7	Comparison of 8' wide and 14' wide panels - rigid and eccentric supports.	48
Table 4.8	Comparison of end fastener types - 8' wide panel.	49
Table 5.1	Effect of fastener spacing on shear stiffness.	54
Table 5.2	Shear stiffness comparison of standard fastener configurations with fully fastened configurations.	55
Table 5.3	Open profile type deck stiffness comparisons - fully fastened configuration.	56
Table 5.4	Flat soffit (LSM) type deck stiffness comparisons - fully fastened configuration.	57
Table 5.5	Experimental shear stiffness and shear strength values.	58
Table 5.6	Development of support connection stiffness.	60
Table 5.7	Comparison of 8' wide and 14' wide panels - rigid & eccentric supports.	62
Table 5.8	Comparison of experimental and SDI shear stiffness values - open profile decks - standard fastener configuration.	66
Table 5.9	Comparison of experimental and SDI shear stiffness values - open profile decks - fully fastened configuration.	66
Table 5.10	Comparison of experimental and empirical shear stiffness values - LSM decks - fully fastened configuration.	67
Table 5.11	Comparison of experimental and SDI shear strength values - open profile decks - fully fastened configuration.	69
Table 5.12	Comparison of experimental and empirical shear strength values - LSM decks - fully fastened configuration.	70
Table A.1	Deck profile dimensions - open profile decks included in study.	76

LIST OF FIGURES

Figure 1.1	Fundamental shear diaphragm.	2
Figure 1.2	Typical steel deck sheeting layout and profile.	3
Figure 1.3	Relationship of sheeting arrangement to structural components.	4
Figure 1.4	Attachment of deck panel to supporting structure.	4
Figure 1.5	Test assembly capable of applying only shear strain to a deck panel.	6
Figure 1.6	Typical load-deflection curve.	7
Figure 1.7	End fastener deck bearing deformations - parallel to span.	8
Figure 1.8	End fastener deck bearing deformations - perpendicular to span.	9
Figure 1.9	Deck support angles - welded to girders.	10
Figure 1.10	Deck support angles - welding to girders not permitted.	10
Figure 2.1	Typical open profile deck.	13
Figure 2.2	Tapered "closed" end configuration.	14
Figure 2.3	Support condition of open profile deck.	14
Figure 2.4	Typical flat soffit deck.	14
Figure 2.5	Flat soffit deck with 24" coverage.	15
Figure 2.6	Flat soffit deck with 16" coverage.	15
Figure 2.7	Support condition of flat soffit deck.	15
Figure 2.8	Side lap fastener arrangement for flat soffit decks.	16
Figure 3.1	Plan of test frame.	21
Figure 3.2	Cross section through deck support beams.	22
Figure 3.3	Cross section through adjustable connector strap.	22
Figure 3.4	Blow-up of pin and bearing assembly.	23
Figure 3.5	Instrumentation of test frame.	23
Figure 3.6	Rigid connection of deck support angle to simulated girder flange.	24
Figure 3.7	Welded eccentric connection of deck support angle to simulated girder flange.	25
Figure 3.8	Plan of strap angles and deck support angle for non-welded connection.	25
Figure 3.9	Non-welded eccentric connection of deck support angle to simulated girder flange.	26
Figure 3.10	Simulation of 80 psf dead load with concrete blocks.	27
Figure 4.1	Shear load vs. shear strain - all unloaded cycles.	31
Figure 4.2	Comparison of initial cycle stiffness to incremental stiffnesses.	32
Figure 4.3	Shear load vs. shear strain - all loaded cycles except ultimate cycle.	32
Figure 4.4	Shear load vs. shear strain - all loaded cycles.	33
Figure 4.5	Shear load vs. shear strain - ultimate cycle.	34
Figure 4.6	Fastener configurations - deck types BUBF18, BUBF16, & BUBF14.	37
Figure 4.7	Fastener configurations - deck types BOSW18 & BO8.5P.	38
Figure 4.8	Fastener configuration - deck type BOS816.	39
Figure 4.9	Fastener configurations - deck types LSM1524, LSM1724 & LSM2224.	40
Figure 4.10	Fastener configurations - deck types LSM1516, LSM1716 & LSM2216.	41
Figure 4.11	Shear load vs. shear strain - ultimate cycles for open profile decks.	42
Figure 4.12	Shear load vs. shear strain - ultimate cycles for flat soffit profile decks.	43
Figure 4.13	8' wide panel with standard end and side lap fasteners.	44
Figure 4.14	12' wide panel with standard end and side lap fasteners.	46

Figure 4.15	Fastener fracture accompanied by bearing deformation.	50
Figure 4.16	Tear-out of deck material at fastener location.	51
Figure 4.17	Support angle warping at tension corner.	52
Figure 4.18	Support angle warping at compression corner.	52
Figure 5.1	Deck profile dimensions used in manual equations.	64
Figure A.1	Open profile diaphragm geometries.	80

CHAPTER 1

INTRODUCTION

1.1 Background

Composite plate girders are a frequent component of highway bridge construction. The design of these girders, which are generally governed by the AASHTO specifications, must consider all loading stages. The loading stage that is often the most critical for composite bridge girders is the loading that occurs during the placement of the concrete bridge deck, when the steel plate girder must carry the entire construction load. This construction load includes the weight of the steel girder, the formwork (including any Permanent Steel Bridge Deck Forms), the fresh concrete, the finishing machine and all other equipment and personnel used in the placement of the concrete.

The design of composite plate girders, particularly in the positive bending moment regions where the neutral axis of the composite member lies near the top flange of the steel section, often results in the selection of a small plate element for this top flange. During the concrete placement phase of construction, this small top flange, which is loaded in compression in the positive bending moment regions, makes the girder susceptible to lateral torsional buckling between the bridge cross-frames or diaphragms.

Under current design specifications, lateral torsional buckling must be resisted through either the use of cross frames and diaphragms or an increase in the size of the top flange of the girder. Current AASHTO specifications limit the maximum spacing of cross-frames or diaphragms to twenty-five feet.¹ Permanent Steel Bridge Deck Forms are not presently permitted to be used as bracing elements to stabilize the top girder flanges against lateral torsional buckling.

1.2 Objective of Study

An investigation of the ability of Permanent Steel Bridge Deck Forms, acting as shear diaphragms, to brace bridge plate girders against lateral torsional buckling during the construction phase is currently being conducted at The University of Texas under the sponsorship of the American Iron and Steel Institute, the Texas Department of Transportation and the Federal Highway Administration. The study includes both analytical and experimental studies.

The analytical portion of this investigation is being conducted using finite element programs to perform eigenvalue buckling and large displacement analyses to determine the deck shear stiffness and strength required to adequately brace a twin girder system against lateral torsional buckling. Strength and stiffness requirements from the twin girder analysis will be used to determine requirements for bridges containing multiple girders.

The shear stiffness and strength of a typical deck system is dependent primarily upon the deck panel sheet profile and span, the fastener type and spacing at both the deck panel ends and the deck panel seams, and the method of connecting the forms to the girders.^{3,4,5,6} The connection is generally accomplished through the use of deck support angles, which can be attached to the bridge girders in

a number of ways. Two of the more common methods of attaching deck support angles to the girders are presented later in this chapter.

The University's experimental investigation of deck system stiffness and strength capacities has been divided into two separate studies. The first study, which is the focus of this report, was primarily an examination of the shear stiffness and shear strength of the deck panels and their associated fasteners unaccompanied by any contribution from the deck support angle configuration. This was accomplished by rigidly attaching the deck panel support angle to the simulated girder. This arrangement, described in section 3.4 of this report, eliminated any reduction in the deck system stiffness and strength which might arise from any flexibility of the connector. The results of experiments conducted utilizing this rigid support angle connection are presented in this report. Additionally, several pilot tests were conducted using two common support angle configurations to determine the effect of the connection upon the stiffness and strength of the deck/fastener/support system. The results of these tests are also presented in this report.

A second experimental study examining the stiffness and strength capacities of various common deck support angle configurations is presently being conducted. The results of the two studies will then be combined to determine reasonable values of system stiffness and strength.

Results from the analytical studies, which calculate the stiffness and strength requirements, can then be compared to the experimental results to determine whether the deck systems are capable of providing adequate bracing to prevent lateral torsional buckling during the concrete placement phase of construction.

1.3 Shear Diaphragms

Shear diaphragms, fundamentally, consist of a structural framework covered by some type of sheeting as shown in Figure 1.1. The sheeting has considerable in-plane stiffness and tends to prevent any in-plane joint rotation in the structural frame when a lateral load is applied to the structure. It is important to note that the sheeting diaphragm action assists only in resisting the loading that causes joint displacement in the plane of the sheeting and offers no help in resisting any out-of-plane loads.⁵ Several diaphragm applications, particularly composite floor systems and bridge deck systems, must combine this sheeting diaphragm action with substantial out-of-plane flexural capacity to support the weight of a fresh concrete slab. The presence of concrete over a corrugated deck panel can increase its diaphragm action shear strength and stiffness.⁴

1.3.1 Building Applications. Historically, diaphragms have been considered to be "short-deep

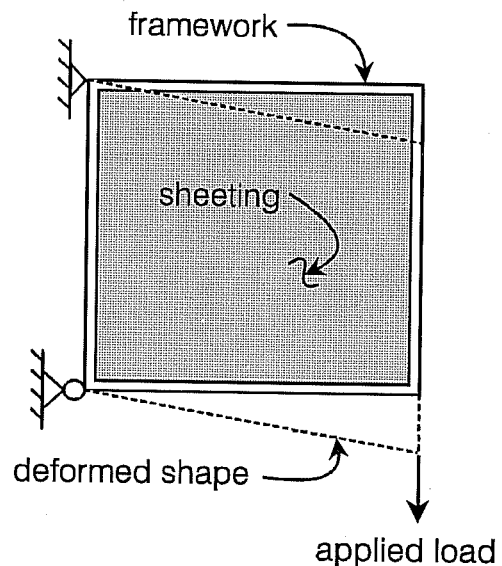

Figure 1.1 Fundamental shear diaphragm.

beams" in which the depth is the dimension parallel to the applied loading and the span is the dimension perpendicular to the load. These shear diaphragms, which are planer structural systems, have been utilized in the roofs, walls and floors of buildings to provide both in-plane shear strength and shear stiffness to the structure.⁵

Current composite construction utilizes composite action where concrete slabs are in contact with steel supporting members in building floor systems.^{2,7} The steel deck forms included in floor slab composite construction are frequently used to provide lateral stability through diaphragm action and serve as slab reinforcement.

Prior to the placement of concrete, composite floor systems generally consist of steel deck sheeting, shown in Figure 1.2, covering a structural system of steel beams. The steel deck sheeting may span either perpendicular or parallel to the span of the diaphragm and is attached to the steel beams by welding mechanical shear connectors through the deck to the beams.⁷ These shear connectors are designed to transfer the shear forces associated with the composite flexural action and can also be designed to carry the additional shear forces associated with the diaphragm action required to stabilize the floor system against lateral forces. When mechanical shear connectors are not used, or when they are not welded through the steel deck, diaphragm action is possible only if the fasteners connecting the steel deck to the structure are adequate to transfer the diaphragm forces from the structure to the deck.⁵

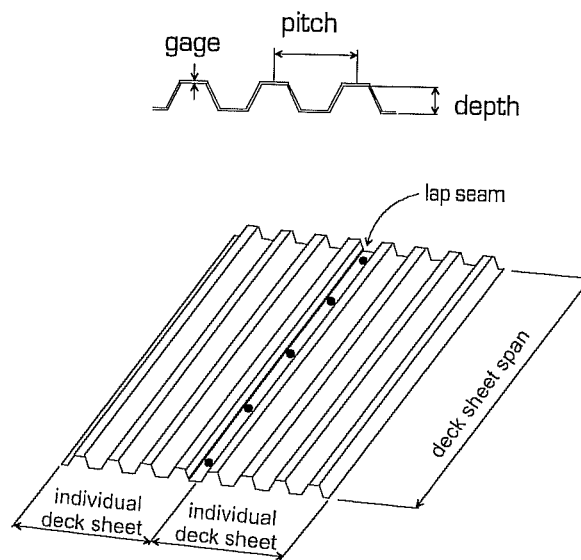

Figure 1.2 Typical steel deck sheeting layout and profile.

Figure 1.3 illustrates the basic sheeting arrangement and its relationship to the structural components mentioned above. The applied load shown in Figure 1.3 would be equivalent to lateral loads acting on a building which are transferred to the structure at the floor level. The sheeting, acting with the structural beams, resists any induced lateral displacement in the manner of a "short-deep beam".⁵ This diaphragm action provides the planer system with a definite capacity to resist in-plane deformations caused by the lateral loads.

In the design of buildings, the design unit of a diaphragm is an individual panel, which is defined as the area bounded by the end edge members and any two adjacent parallel members.⁵ Figure 1.4 shows an individual panel and illustrates the three types of fasteners used in the attachment of the deck panel to the supporting structure.

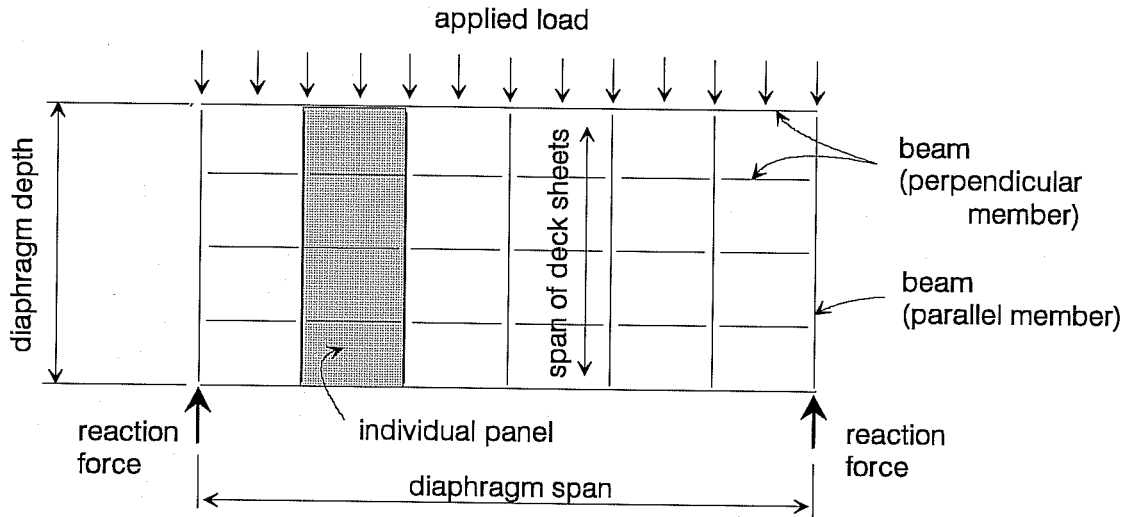

Figure 1.3 Relationship of sheeting arrangement to structural components.

Sheet-to-perpendicular member fasteners are the primary connection between the deck sheeting and the supporting structure. It is essential that the deck sheets are firmly attached to the perpendicular supporting members through the troughs of the deck profile. Fasteners located at perpendicular members have a significant effect on the stiffness of the diaphragm, with diaphragms having fasteners at every deck profile trough demonstrating considerably more stiffness than diaphragms having fasteners only at alternate troughs.⁵

Fasteners connecting deck sheets to parallel members are often considered optional due to the fact that diaphragm action is only marginally effected by the omission of these fasteners.⁵ It should be noted, however, that when these fasteners are omitted and the diaphragm is fastened only at the perpendicular members, the entire applied load must be transferred to the deck sheeting through the sheet to perpendicular member fasteners. This places considerable demands on the sheet to perpendicular member fasteners, particularly the fasteners at the outside edges of the deck panel. Significant demands will always be placed on the deck panel end fasteners in bridge deck construction since there are never any parallel members present. These demands will be compounded by the fact that there are also no intermediate perpendicular members available for deck attachment.

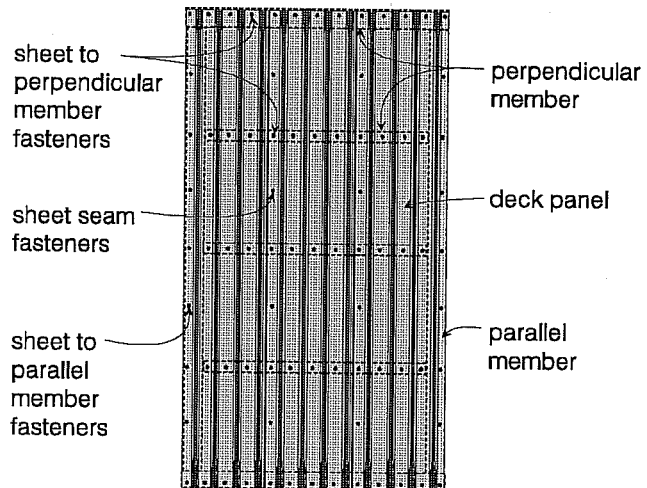

Figure 1.4 Attachment of deck panel to supporting structure.

Seam fasteners, which connect the longitudinal edge of one individual deck sheet to the edge of the adjacent deck sheet, are often designed to dictate the mode of failure of a deck panel in building diaphragms. This mode of failure, involving the tearing of the deck sheet material at each seam fastener along a given seam, produces a ductile failure, providing the seam fasteners do not fracture in a brittle manner.⁵

1.3.2 Potential Bridge Applications. Current design specifications do not allow the Permanent Steel Bridge Deck Forms to be used as shear diaphragms to brace the bridge girders. It is possible, however, that the girder/deck form system may possess substantial in-plane shear strength and stiffness which could realistically be used to reduce or eliminate other bracing members. The system of girders and deck forms in bridge construction is quite similar to composite floor systems used in buildings which consist of a steel deck sheeting covering a system of structural beam members. There are, however, several important differences between bridge deck systems and composite floor systems that are of particular interest when considering the shear diaphragm capacity of a given deck system.

First of all, there is only one arrangement of deck sheeting possible for bridge deck construction. The steel deck sheeting must span between the bridge girders (perpendicular members) and there are no parallel members available for support or attachment of the longitudinal deck edges. It should also be noted that deck forms are fastened to bridge girders only at the ends of individual deck sheets as there are no intermediate members between girders, and deck sheets are not run continuously over the girders. Because of this simple span arrangement, the only fasteners needed for the installation of bridge deck forms are sheet-to-perpendicular-member fasteners at the deck sheet ends and sheet-to-sheet fasteners at the individual deck sheet seams.

Secondly, attachment of deck panels to bridge girders by welding mechanical shear connectors through the deck is not permitted. Attachment of the deck panels to the supporting members is usually accomplished through the use of screws whose strengths will often control the capacity of the diaphragm system.

Finally, bridge plate girder systems usually differ from composite floor beam systems in the following ways:

- bridge plate girders have smaller top flanges than composite floor beams, particularly the compression flange.
- bridge girder spacings are larger than composite floor beam spacings.
- bridge girder spans are much larger than composite floor beam spans.

The small compression flanges combined with a large dead load carried by each bridge girder, due to the increased spacings and spans, increases the girders susceptibility to lateral torsional buckling during the placement of the concrete deck.

For the purpose of this study, the design unit of a bridge deck diaphragm, which will be referred to as a deck panel, will be defined as the area bounded by the bridge girders and a width of approximately eight feet. This deck panel width was chosen to permit the utilization of a combination

of several individual deck sheets and still fit in the test apparatus. It should be noted that a deck panel is composed of several individual deck sheets.

Sheet-to-perpendicular-member fasteners and seam fasteners are the only fasteners required for the bridge deck system. It remains essential that the deck sheets are firmly attached to the supporting members at the ends of the deck sheets. It is assumed that fasteners located at perpendicular end members will have a significant effect on the stiffness of the diaphragm and that diaphragms having fasteners at every deck profile trough will demonstrate considerably more stiffness than diaphragms having fasteners only at alternate troughs. The effect of end fastener spacings along with seam fastener spacings will be investigated in this study.

1.4 Diaphragm Strength

The shear strength of a deck diaphragm can be determined experimentally by testing a deck panel, consisting of several individual deck sheets, in a test assembly such as that shown in Figure 1.5.⁴ As the lateral load P is increased, the frame tends to displace as shown. This displacement is restrained by the attached deck panel.

When the deck panel is loaded in shear to failure, a load-deflection curve having the shape of the curve shown in Figure 1.6 is produced. The strength P_{ult} is defined as the maximum load the deck panel can sustain.⁴

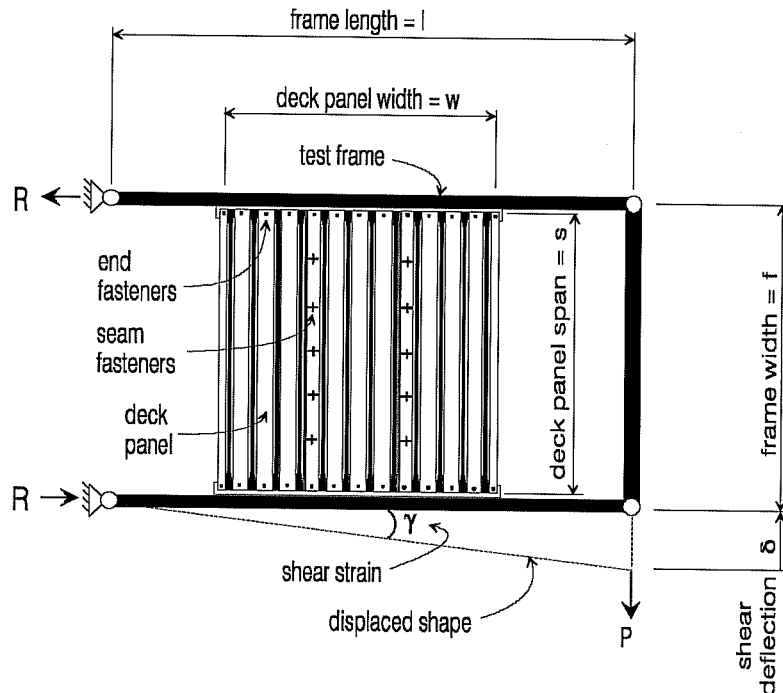

Figure 1.5 Test assembly capable of applying only shear strain to a deck panel.

The total shear along each end of the deck panel must be equivalent to the reaction R at the fixed support as depicted in Figure 1.5. This reaction can be determined statically by summing moments about either support and is equal to Pl/f . The average shear (S_{avg}) along each deck end is then computed as $(Pl/f)/w$. For the purposes of this study the diaphragm shear strength will be defined as S_{avg} computed at the ultimate load the deck panel can sustain (P_{ult}).

$$S_{avg} = (Pl / f) / w \quad \text{kips / inch}$$

(Eq. 1.4-1)

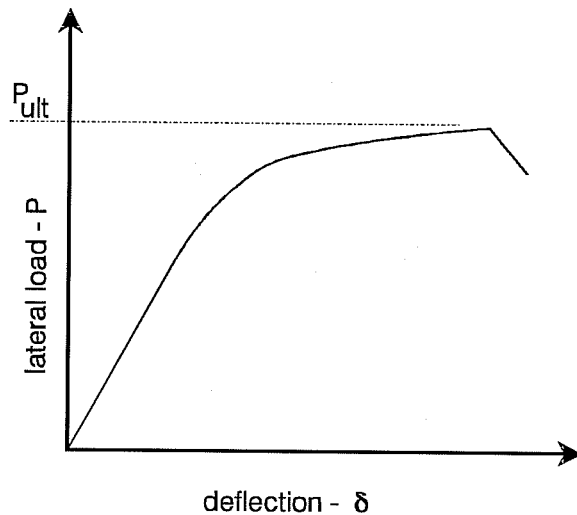

Figure 1.6 Typical load-deflection curve.

It should be noted that bridge decks are typically fastened to supporting members only at the ends of the deck sheets. This fastening configuration produces much larger forces, in the end fasteners, parallel to the deck span than the fastener forces generated perpendicular to the span. These large end fastener forces parallel to the span of the deck will generally control P_{ult} and consequently the shear strength of the deck panel.⁴

1.5 Failure Modes

The shear strength of a deck panel will normally be controlled by a combination of one or more of the following failure modes:

- (1) failure of an end fastener
- (2) failure of a seam fastener
- (3) deck bearing deformation at an end fastener with bearing deformation in a direction parallel to the deck span
- (4) deck bearing deformation at an end fastener with bearing deformation in a direction perpendicular to the deck span
- (5) deck bearing deformation at a seam fastener
- (6) overall shear buckling of the deck panel
- (7) failure of the deck support member

Each of the failure cases are detailed below.

1.5.1 Failure of an End Fastener. This non-ductile failure occurs with the fracture of an end fastener and results in a sudden loss of shear strength. Since bridge diaphragms are not fastened to parallel members along their longitudinal edges, the load applied to the deck panel must be transferred to the sheeting entirely through the end fasteners. This produces large forces, parallel to the deck span, in the end fasteners and in particular on the fasteners located at the corners of the deck panel.⁵ These large forces in the corner fasteners can result in fastener fractures, particularly when used with thicker decks.

1.5.2 Failure of a Seam Fastener. Seam fastener fractures are considerably more ductile than end fastener fractures due to the fact that seam failures cannot occur without movement of the adjacent sheet, thereby, providing some ductility to the system.⁵ This type of failure is not likely to occur in bridge deck panels, once again, due to the lack of deck fastening to parallel members which will force fractures of the end fasteners before enough force can be generated in the seam fasteners to cause fracture.

1.5.3 Bearing Deformation at End Fasteners - Parallel to Span. It was noted in section 1.5.1 that large forces are generated in end fasteners when, as is the case for all bridge decks, there are no fasteners connecting the deck panel to parallel supporting members. These large forces, which are parallel to the deck span, will produce significant bearing deformation in the deck material at the end fasteners. This deformation, shown in Figure 1.7, is also in a direction parallel to the deck span. It was also pointed out that the forces are largest at the corner fasteners of the deck panel with adjacent fasteners seeing smaller forces as we move away from the corners. This force distribution along the end of the deck panel results in larger bearing deformations at the corners of the panels than is found at the interior fasteners.⁵ It should be noted that as the bearing deformations occur a redistribution of fastener forces takes place along the end of the deck panel, however, the corner fasteners will continue to realize the largest force and will generally be the first to fail (either a fastener fracture or sheet tear-out at a fastener) should the loading become large enough to cause failure.

The amount of bearing deformation in the deck is dependent on the thickness and strength of the deck, with thinner decks experiencing more deformation resulting in a more ductile failure. Decks fabricated of thicker materials and decks from higher strength material will show a reduction in bearing deformation and may even approach a brittle, non-deforming, non-ductile fastener failure.

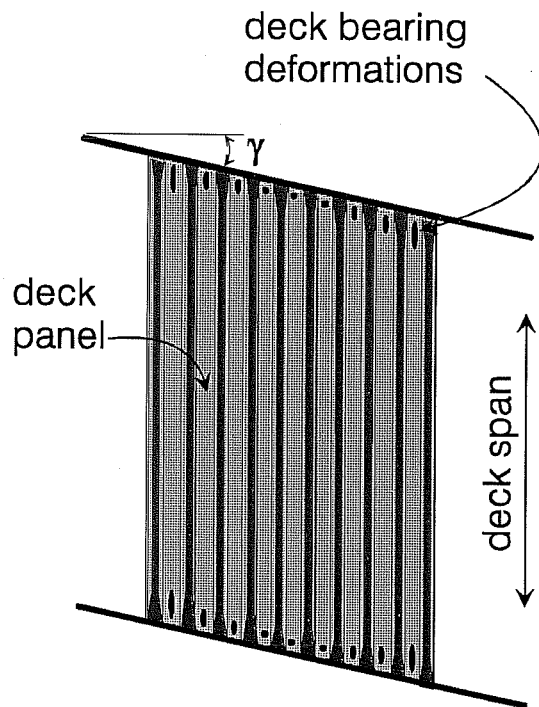

Figure 1.7 End fastener deck bearing deformations - parallel to span.

1.5.4 Bearing Deformation at End Fasteners - Perp. to Span. The end fasteners also carry a shear load in a direction perpendicular to the span of the deck. These forces are generally not large enough to cause bearing deformation perpendicular to the deck span as shown in Figure 1.8.

1.5.5 Deck Bearing Deformation at a Seam Fastener. Bearing deformations at fasteners along a lap seam usually consist of a simultaneous deformation at all seam fasteners along the particular seam. This is a very ductile type of failure and, as was stated earlier, cannot take place without some movement of the adjacent deck sheet. This movement will require that some bearing deformation at the end fasteners of the adjacent sheet has taken place.⁵

1.5.6 Overall Shear Buckling of Deck Panel. This type of failure involves the buckling of the entire deck sheet and is very unlikely with the relatively thick deck sheets used in bridge deck forms.

1.5.7 Failure of the Deck Support Angle. Deck support angles typically are of substantially greater thickness than the supported deck panels and consequently a deck failure or fastener failure will usually occur prior to any support failure and often prior to any bearing deformation in the support angle at the fasteners. It is expected that failure of a deck support member will not be encountered in the tests utilizing a deck support angle that is rigidly attached to the simulated girder flange.

It should be noted, however, that several tests were conducted using two standard deck support configurations. Due to the load eccentricity introduced in these configurations, it is expected that considerable warping of the deck support angles may take place but failure of the support member is still not expected.

1.6 Diaphragm Shear Stiffness

The shear stiffness of a diaphragm can also be measured by testing in the test assembly of Figure 1.5. The deck panel shear stiffness is important in assessing how forces are transferred, through the deck panel, from one bridge girder to the other.⁵ This force transfer is important to the stability of the deck/girder system.

The shear stiffness of a corrugated diaphragm (G') has traditionally been defined as S_{avg}/γ where S_{avg} is the average shear along the panel end and gamma (γ) is the shear strain in the deck

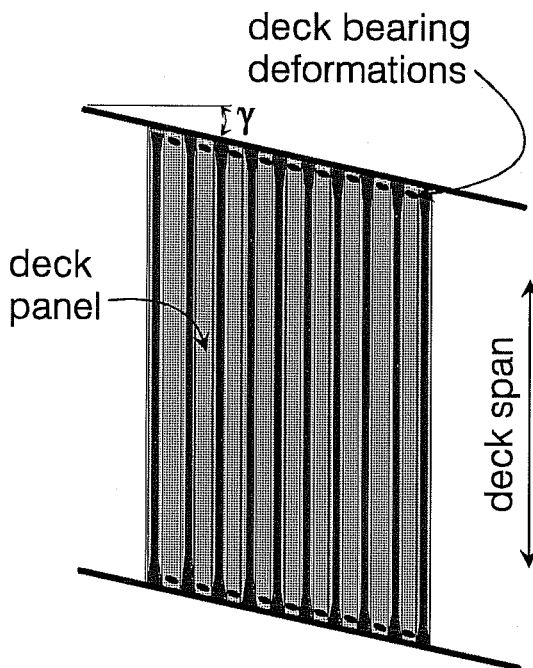

Figure 1.8 End fastener deck bearing deformations - perpendicular to span.

panel.⁴ S_{avg} was defined in Section 1.4 as $(Pl/f)/w$ and the shear strain γ is the angular deck displacement as shown in Figure 1.5. Combining these values we obtain the expression for G' as:

$$G' = Pl / fw\gamma \quad \text{kips / inch} \quad (\text{Eq. 1.6-1})$$

The load-deflection curve presented in Figure 1.6 illustrates a non-linear response as the load approaches P_{ult} , making the shear stiffness dependent on the load at which the shear strain is measured. Selection of an appropriate load which will produce reasonable shear stiffness values will be covered in Chapter 4.

Deck shear stiffness depends distinctly on deck material strength and modulus of elasticity, deck thickness, depth of deck profile, pitch of deck corrugations and span of deck panel. Previous studies⁴ have indicated that diaphragm shear stiffness is also affected by the following factors:

1. Decks with end closures exhibit considerably more resistance to distortion of the sheeting profile than do open ended decks resulting in substantially more shear stiffness.
2. Number of end fasteners attaching deck panel to support members. Deck panels with fasteners in every deck trough exhibit greater stiffness than panels fastened in every other trough.
3. Number of seam fasteners connecting adjacent deck sheets together in a deck panel. Additional seam fasteners produce an increase in stiffness.
4. Flexibility of deck support member.

The shear stiffness of a deck system is certainly dependent upon a combination of all of these factors.

1.7 Deck Fasteners

Fasteners required in the erection of Permanent Steel Bridge Deck Forms consist of end fasteners which fasten the deck sheets to the girders and seam fasteners, referred to as side lap fasteners, which connect the individual sheets together at the sheet overlaps.

End fasteners, which connect the light gage deck sheets to the heavier support members attached to the girders, customarily consist of arc spot welds, self-drilling TEKS screws, self-tapping screws or powder-actuated pin fasteners.

Side lap fasteners connecting individual light gage deck sheets at their seams include arc spot welds, self-drilling TEKS screws or button-punched material.⁸

Presently, self-drilling TEKS screws are the dominant method of attachment of bridge deck forms for both end fastening and side-lap fastening. For this reason, Buildex 1/4-14 self-drilling TEKS

screws will be used throughout this study. These screws are Ind. Hex Washer Head No. 2 TEKS, case hardened and partially threaded. Screws for end fastening will be 1/4" diameter x 1 1/8" long. Side lap screws will be 1/4" diameter x 3/4" long or 1 1/8" long depending on the deck profile being tested. This particular type of TEKS screw is used without a neoprene or metal washer.

1.8 Standard Deck Support Angle Configurations

There are several methods of fastening Permanent Steel Bridge Deck Forms to their supporting girders all of which allow for elevation adjustment of the deck with respect to the top of the plate girder. In order to facilitate the proper erection of bridge deck forms, this elevation adjustment capability is very desirable. Two support angle configurations commonly used in the industry today were chosen to investigate whether the method of deck support might contribute to a reduction in the shear strength or shear stiffness of a deck panel diaphragm system.

The first configuration, shown in Figure 1.9, is used when welding to the girder flange is permitted and consists of welding the deck support angles directly to the top of the girder's top flange. Once the support angles are welded to the girders, the deck panels can then be fastened with end fasteners to the angles. Current decks in use require that a minimum distance of 1/2" be maintained between the end fastener centerline and the deck end and the angle edge as shown in Figure 1.9. This requirement necessitates a minimum 1" lap of the deck panel onto the deck support angle.

When welding to the girder flange is not allowed, a more complicated method of deck support angle attachment, such as that presented in Figure 1.10, is used. This method usually consists of welding the deck support angles to loose strap angles which are typically spaced at approximately one foot on center along the girder span. These strap angles are not welded to the girder, however, hold-down clips are used to prevent any uplift of the deck panels. As before, the deck panels are then fastened to the deck support angles.

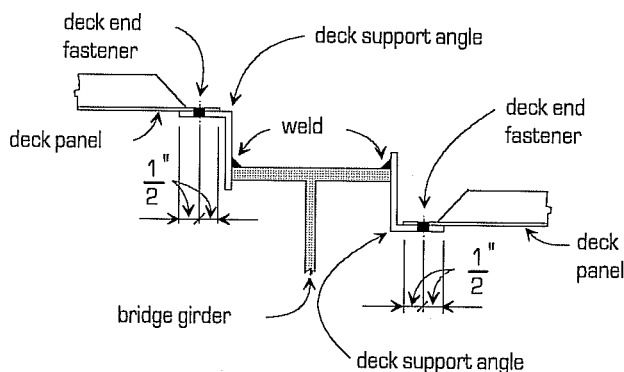

Figure 1.9 Deck support angles - welded to girders.

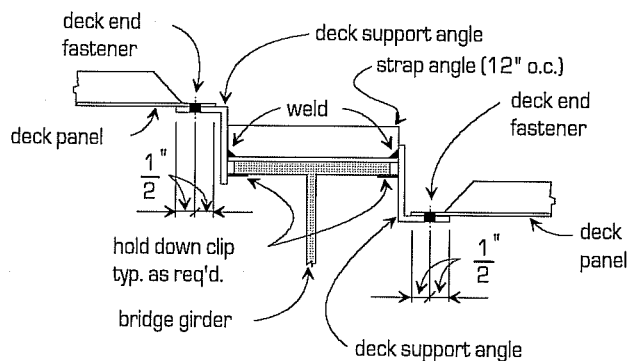

Figure 1.10 Deck support angles - welding to girders not permitted.

It should be noted that both methods of deck support angle attachment can introduce an eccentricity in the transfer of the lateral deck panel load to the top flange of the bridge girder. Because of this eccentricity, the flexibility of the deck support angle may substantially affect the overall stiffness of the girder/deck panel system.

The primary emphasis of this study is an attempt to determine the strength and stiffness capacities of various deck profiles without any contribution of the deck support angle, however, several pilot tests were conducted using the two support attachments described above to determine preliminary values of diaphragm strength and stiffness with the flexibility of the support angle included. The results of these pilot tests will be presented in this study.

CHAPTER 2

PERMANENT METAL DECK FORM TYPES

2.1 Overview

Deck types included in the testing program were Permanent Steel Bridge Deck Forms fabricated from zinc-coated, structural quality sheet steel conforming to ASTM Specification A446 Grade C or Grade E. The zinc coating requirements were ASTM A525, Designation G165, as required by the Federal Highway Administration specifications. Two different deck profile types were considered in this study. We will refer to these two types as "open deck" and "flat soffit deck".

Conventional open profile decks generally consist of open trough ribs which are filled with concrete during placement of the deck slab. The concrete in these troughs is not included in composite strength computations. The open troughs are frequently filled with styrofoam inserts prior to concrete placement to decrease the dead load associated with the deck slab and reduce the concrete quantity requirements. A typical open profile deck is shown in Figure 2.1 which illustrates the pitch, depth, thickness (gage), individual sheet cover width, rib trough and rib crest of a typical open deck panel. The pitch is the spacing between consecutive ribs and the depth is simply the overall depth of the section. Cover width denotes the amount of cover each individual deck sheet provides when used in conjunction with other deck sheets. The thickness of the deck material is referred to as its gage. All of the open profile decks tested were the tapered "closed" end sheets type, which indicates that the deck ends between the deck rib troughs are closed.

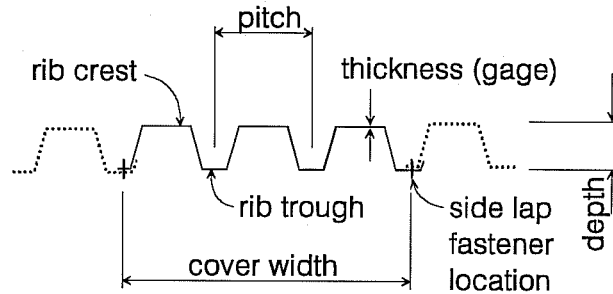

Figure 2.1 Typical open profile deck.

Figure 2.2 shows a typical example of a tapered end sheet. This type of deck panel eliminates the need for end closure flashings and also helps the deck resist warping due to lateral loads. As indicated in Figure 2.3, the entire depth of an open profile deck is positioned above the support surface. End fasteners and side lap fasteners are located only in the rib troughs of open deck types. Various open decks manufactured by Buffalo Specialty Products, Inc. and also Bowman Metal Deck, a division of Cyclops Corporation, were tested. These decks are described in the following sections.

The flat soffit deck forms tested were manufactured by Bowman Metal Deck and are fabricated in sheets consisting of two open trough ribs and two rib covers. A profile of a flat soffit deck is illustrated in Figure 2.4. As shown in Figures 2.5 and 2.6, these deck forms can be installed such that one or both of the trough ribs can be covered. This results in the partial (24" cover) or

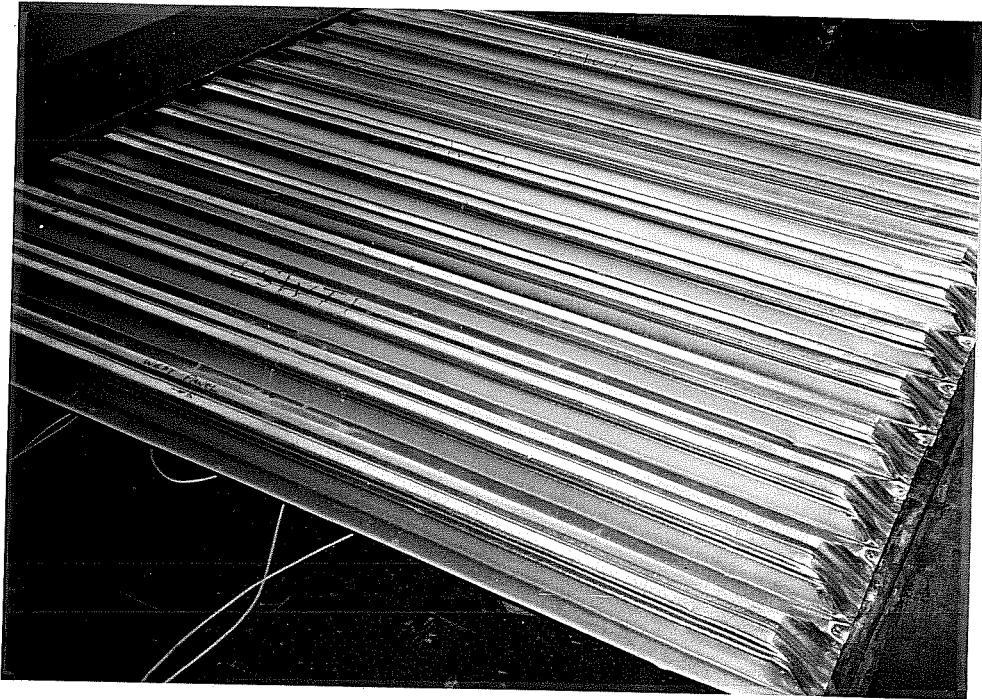

Figure 2.2 Tapered "closed" end configuration.

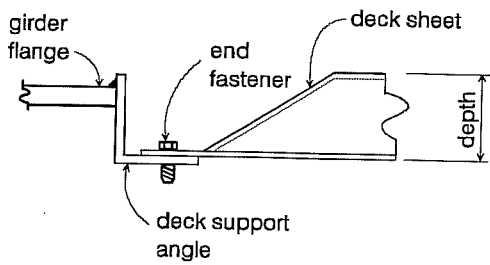

Figure 2.3 Support condition of open profile deck.

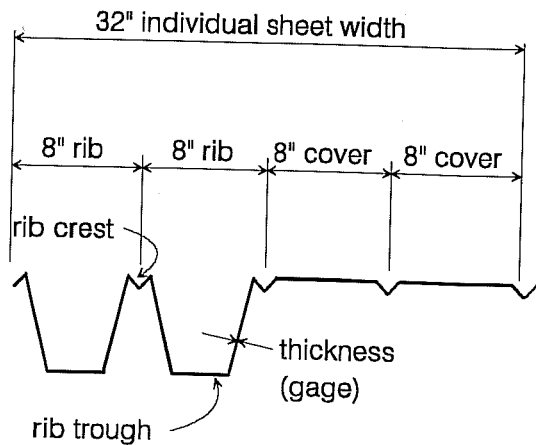

Figure 2.4 Typical flat soffit deck.

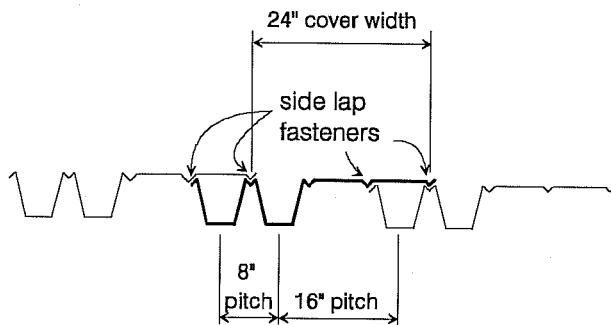

Figure 2.5 Flat soffit deck with 24" coverage.

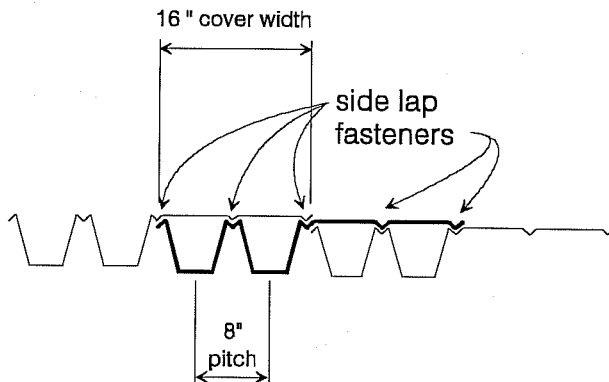

Figure 2.6 Flat soffit deck with 16" coverage.

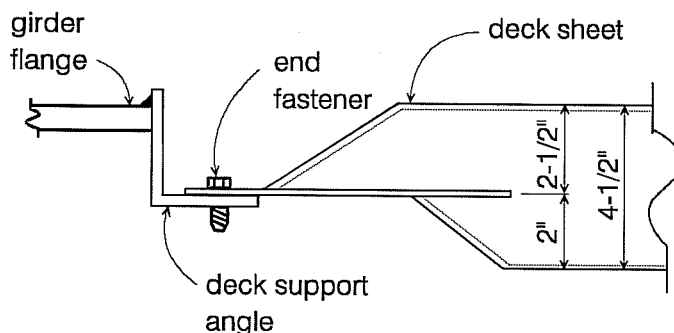

Figure 2.7 Support condition of flat soffit deck.

complete (16" cover) elimination of excess concrete being required to fill the troughs. Deck forms installed with a 16" coverage will also exhibit an increase in flexural strength over those installed with a 24" coverage. The deck ends between the deck rib troughs are closed, similar to the open deck types, once again eliminating the need for end closures. The flat soffit decks are supported near the mid-depth of the profile as shown in Figure 2.7. It should be noted that, for the flat soffit decks, end fasteners are located only at rib troughs, but side lap fasteners are not. As shown in Figures 2.5, 2.6 and 2.8, side lap fasteners are actually located at the points of contact between the deck panel covers and deck rib crests. This provides for a much greater number of possible side lap fastener locations in the flat soffit decks. These flat soffit decks are also described below.

The only type of deck fasteners used in this study were 1/4" diameter Buildex TEKS screws. These TEKS screws were used at both end fasteners and side lap fasteners. End fasteners are the fasteners that attach the deck panels to the support members and side lap fasteners join the individual deck sheets at the seam between one deck sheet and the next. Tests were conducted with end fasteners and side lap fasteners in two basic configurations. Initially panels were tested with end fasteners located in alternating troughs and with minimal side lap fasteners. The panels were then tested with end fasteners in all troughs and with additional side lap fasteners to determine the specific

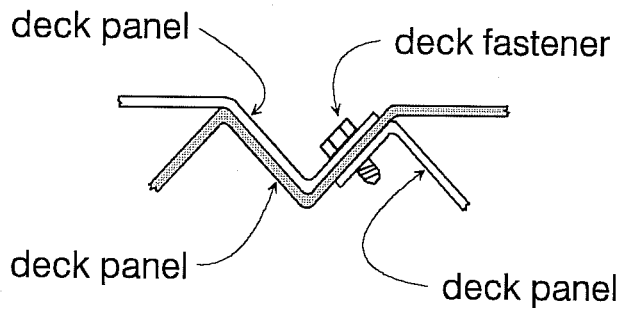

Figure 2.8 Side lap fastener arrangement for flat soffit decks.

influence of these additional fasteners on the stiffness of each deck type. These fastener configurations will be presented with the results of the tests in Chapter 4.

2.2 Open Deck

The various open profile decks tested in this study are presented in Table 2.1. Figure 2.1 identifies the properties listed, except for the deck form span, which is

Table 2.1 Open profile decks included in test program.

Deck Type	Manufacturer	Manufacturer's Designation	Gage	Depth (inches)	Pitch (inches)	Coverage (inches)	Span (feet)	Material Grade
BUBF18	Buffalo	Bridgeform	18	2.5	6.5	26	8'-0"	E
BUBF16	Buffalo	Bridgeform	16	2	6	24	7'-9"	E
BUBF14	Buffalo	Bridgeform	14	2.5	6.5	26	8'-6"	E
BOS816	Bowman	Super 8	16	3	8	24	10'-0"	C
BOSW18	Bowman	Strong Web	18	2.5	8	32	8'-0"	C
BO8.5P	Bowman	2 x 8½	16	2	8.5	34	7'-8"	C

simply the overall length of the deck panel tested. In addition, each deck is identified by a specific deck type number (i.e., BUBF18). These numbers identify each specific deck type and will be referred to in other sections of this document.

Buffalo Bridgeform deck forms (denoted as BU____) were supplied by Buffalo Specialty Products, Inc. of Buffalo, New York. Bowman Open Bridge deck forms (denoted as BO____) were supplied by Bowman Metal Deck, a division of Cyclops Corporation, located in Pittsburgh, Pennsylvania.

2.3 Flat Soffit Deck Forms

The various flat soffit deck profiles tested in this study are presented in Table 2.2. Figures 2.4, 2.5 and 2.6 identify the tabulated properties for the flat soffit deck profiles.

Table 2.2 Flat soffit decks included in test program.

Deck Type	Manufacturer	Manufacturer's Designation	Gage	Depth (inches)	Pitch (inches)	Coverage (inches)	Span (feet)	Material Grade
LSM1516	Bowman	LSM	15	4.5	8	16	12'-10"	C
LSM1524	Bowman	LSM	15	4.5	8 & 16	24	12'-10"	C
LSM1716	Bowman	LSM	17	4.5	8	16	12'-10"	C
LSM1724	Bowman	LSM	17	4.5	8 & 16	24	12'-10"	C
LSM2216	Bowman	LSM	22	4.5	8	16	8'-11½"	E
LSM2224	Bowman	LSM	22	4.5	8 & 16	24	8'-11½"	E

2.4 Deck Panel Test Widths

The majority of the tests performed in this study were conducted on deck panels approximately eight feet in width. These deck panel widths were actually a multiple of the cover widths for individual deck sheets, and consequently, varied for each deck profile type. For example, Bowman Strongweb deck forms (BOSW18) with a 32" cover width would require 3 individual deck sheets and would result in a deck panel 96" wide. Likewise, three Bowman 2 x 8 1/2 deck forms (BO8.5P) having a 34" cover width would result in a deck panel width of 102". Deck panel widths, for all deck profiles tested, ranged from 96" to 104" but will be referred to as 8' deck panel widths for the purpose of this study. All tests were conducted using deck panels containing at least three individual deck sheets.

Additionally, two tests were conducted to compare the effect of panel width upon the measured stiffness and strength. One test was done using six Bowman Super 8 deck panels (cover width of 24") which resulted in a deck panel width of 144". The second test was done using seven Bowman LSM2224 deck panels (cover width of 24") producing an overall panel width of 168".

It should be noted that partial deck sheets were required at the outside edges of the LSM deck panels in order to achieve a complete deck panel. For the LSM 16" cover width configuration, a starter deck sheet of two rib sections was installed in order to accept the first full deck sheet and a partial deck sheet consisting of two cover sections was installed at the opposite edge to complete the deck panel. Similarly for the LSM 24" cover width configuration, a starter sheet of one rib section and a final sheet of one rib section and two cover sections were required.

2.5 Deck Strength Properties

Tension tests, in accordance with ASTM A370-92 "Standard Test Methods and Definitions for Mechanical Testing of Steel Products", were conducted on test specimens obtained from two separate deck panels of each deck profile. Results presented are the average of the two specimens.

These specimens were standard rectangular plate-type tension test specimens 1.5" wide with an 8" gage length. All tension tests were performed in a hydraulic testing machine. The measured deck properties, presented in Table 2.3, were obtained from the test specimens and their corresponding tension tests.

Measured uncoated deck thicknesses were obtained by measuring the thickness of test specimens following removal of the zinc coating with hydrochloric acid. Thickness of material was measured before and after removal of the zinc to determine the coating thickness.

Dynamic yield stresses were obtained by averaging three distinct dynamic stress measurements taken along a well defined yield plateau for each specimen. The three stress measurements were generally within 1 ksi of each other for the Grade C decks and within 2 ksi for the Grade E decks. Static yield stresses are also the average of three static stress measurements along the yield plateau. The static measurements were obtained by measuring the stress two minutes after the rate of straining in the specimen was brought to zero.

In addition to the measured values, U.S. standard thicknesses² and ASTM A446 specified minimum yield and ultimate stresses are also shown for each deck profile type. Comparisons of the measured and specified minimum values are included.

All deck properties meet the ASTM A446 specification except the BO8.5P deck type which has a measured ultimate strength approximately 7% below the specified minimum. Several of the deck types also had measured thicknesses less than the U.S. Standard thickness for their respective nominal gages.

Table 2.3 Experimental and ASTM deck properties

DECK PROFILE TYPE	Deck Support Angles	BUBF18	BUBF16	BUBF14	BOS816	BOSW18	BO8.5P	LSM1516	LSM1524	LSM1716	LSM1724	LSM2216	LSM2224
Nominal gage	8	18	16	14	16	18	16	15	15	17	17	22	22
Coated thickness (measured-inches)	0.166	0.052	0.064	0.077	0.066	0.052	0.068	0.065	0.065	0.058	0.058	0.035	0.035
U.S. Standard thickness (inches)	0.168	0.052	0.064	0.079	0.064	0.052	0.064	0.071	0.071	0.058	0.058	0.034	0.034
% U.S. Standard	99%	100%	100%	97%	103%	100%	106%	92%	92%	100%	100%	103%	103%
Uncoated thickness (measured-inches)	0.162	0.048	0.060	0.072	0.062	0.047	0.062	0.060	0.060	0.054	0.054	0.030	0.030
U.S. Standard thickness (inches)	0.164	0.048	0.060	0.075	0.060	0.048	0.060	0.067	0.067	0.054	0.054	0.030	0.030
% U.S. Standard	99%	100%	100%	96%	103%	98%	103%	90%	90%	100%	100%	100%	100%
Galvanizing thickness (measured-inches)	0.004	0.004	0.004	0.004	0.005	0.005	0.005	0.005	0.005	0.004	0.004	0.005	0.005
Nominal Material Grade (ASTM A446)	C	E	E	E	C	C	C	C	C	C	C	E	E
Dynamic Yield Stress (measured-ksi)	48	92	103	88	49	54	43	61	61	56	56	93	93
Dynamic Yield Stress (ASTM A446-ksi)	40	80	80	80	40	40	40	40	40	40	40	80	80
% ASTM	120%	115%	129%	110%	123%	135%	108%	153%	153%	140%	140%	116%	116%
Static Yield Stress (measured-ksi)	45	89	100	85	47	50	41	58	58	52	52	90	90
Ultimate Stress (measured-ksi)	61	94	107	89	61	66	51	73	73	69	69	94	94
Ultimate Stress (ASTM A446-ksi)	55	82	82	82	55	55	55	55	55	55	55	82	82
% ASTM	111%	115%	130%	109%	111%	120%	93%	133%	133%	125%	125%	115%	115%

CHAPTER 3

TEST APPARATUS & PROCEDURE

3.1 Overview

The shear stiffness of a panel of deck was measured by testing the panel in an assembly such as that in Figure 1.5. As the load P is increased, the shear deflection, δ , is measured and the shear strain, γ , in the panel can be determined. The stiffness may then be computed as presented in Chapter 1.

3.2 Test Frame

In order to impart a shear deflection on the deck panel and at the same time limit any frame deformations, a test frame was designed and constructed that had sufficient stiffness in the plane of the loading to eliminate all undesirable movements and deformations. A plan of this frame is presented in Figure 3.1.

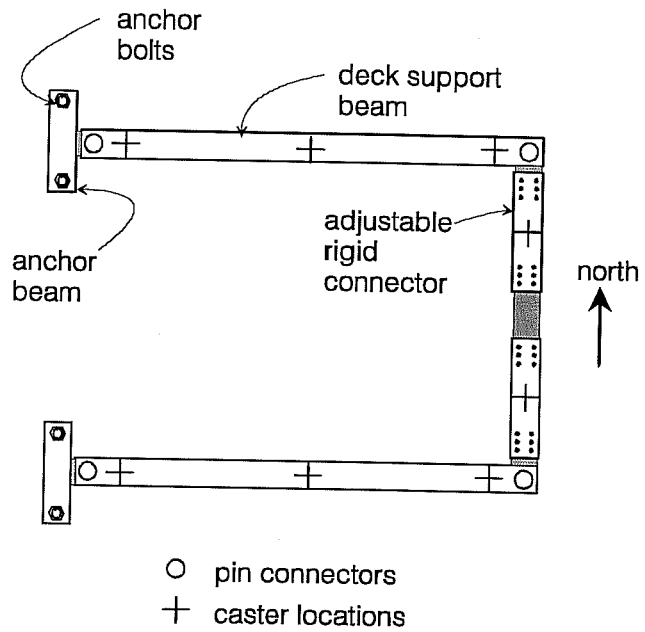

Figure 3.1 Plan of test frame.

The deck support beams were rigidly fixed against any translational movement on their west ends through a pin connection to the anchor beams. This connection was accomplished by pinning the end of each support beam through a clevis plate, which was bolted to the anchor beam. The anchor beams were rigidly fixed to a three foot thick reaction slab with two 4" diameter prestressed anchor bolts per beam. This arrangement allowed free in-plane rotation of the deck support beams at the west end, while at the same time restricting all translation of these beam ends. The anchor beams were checked during the initial tests to insure that these beams incurred no movement during application of lateral load.

The east ends of the deck support beams were free to translate and rotate in the plane of the frame. Once again, this was accomplished by pinning the ends of the support beams through plates at the ends of the adjustable rigid connector.

The weight of the deck support beams and the adjustable rigid connector were transferred to the reaction slab through eight heavy duty casters. Three of these casters were located on each support beam and two were located on the adjustable connector. These casters ran on smooth, flat steel plates positioned on the reaction slab to eliminate any roughness which may have been present on the concrete surface.

The deck support beams were designed and constructed to provide sufficient in-plane flexural stiffness to reduce the beam deformation that would occur under any of the in-plane loads expected during the tests. Since the deck forces are located at the top of the support beams, the beams were boxed to increase their torsional stiffness. A 1" by 18" plate was welded the full length of each support beam to provide this torsional stiffness and also to simulate the top flange of a typical bridge plate girder. Figure 3.2 shows a cross section of the deck support beams. Heavy duty casters were bolted to the deck support beams using 4 - 1/2" diameter bolts.

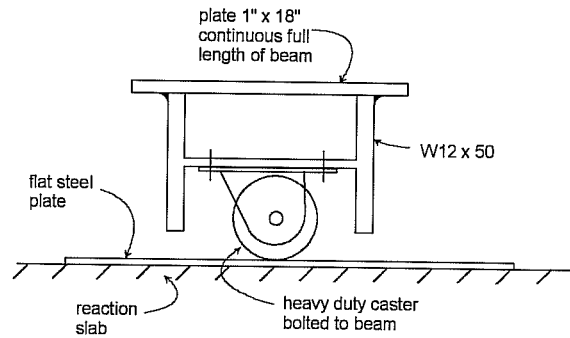

Figure 3.2 Cross section through deck support beams.

The east ends of the deck support beams were connected through an adjustable connector strap as shown in cross section in Figure 3.3. This connector was composed of a 2" plate sandwiched between two C10 x 25 channels and bolted with 1" diameter A325 bolts. The bolts were tightened to insure no slippage in the connection. This bolted assembly allowed for adjustment of the frame to accommodate various spans of deck, while at the same time providing enough stiffness to insure that the support beams remained parallel to each other under all applied lateral loads.

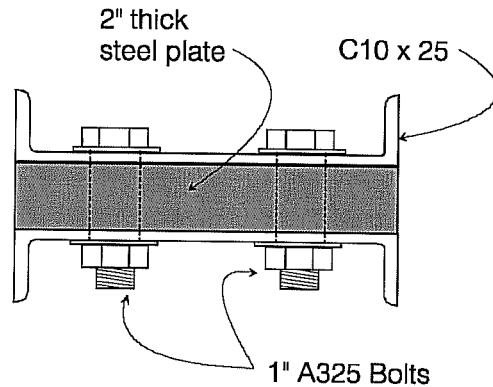

Figure 3.3 Cross section through adjustable connector strap.

The pin connections at the four corners of the test frame were assemblies consisting of a 2.5" diameter pin running in heavy duty needle roller bearings on both sides of the anchor beam clevis plates and both sides of the rigid connector end plates. These bearings were seated in specially fabricated housings which were bolted to the support beams and seated with steel filled epoxy. Figure 3.4 shows a blow-up of the pin and bearing assembly.

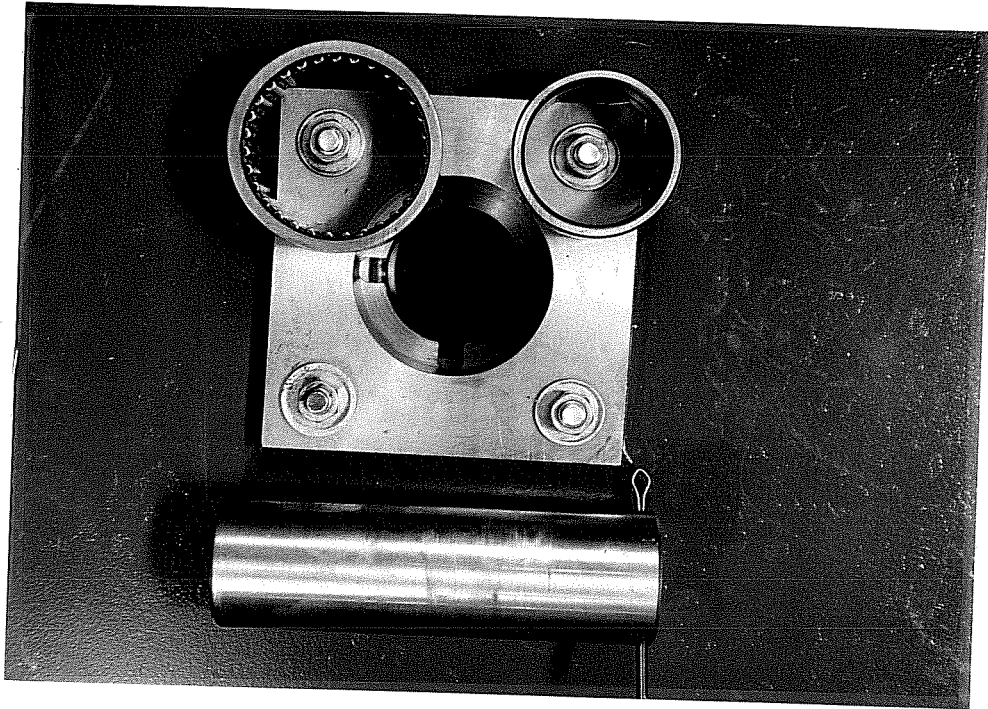

Figure 3.4 Blow-up of pin and bearing assembly.

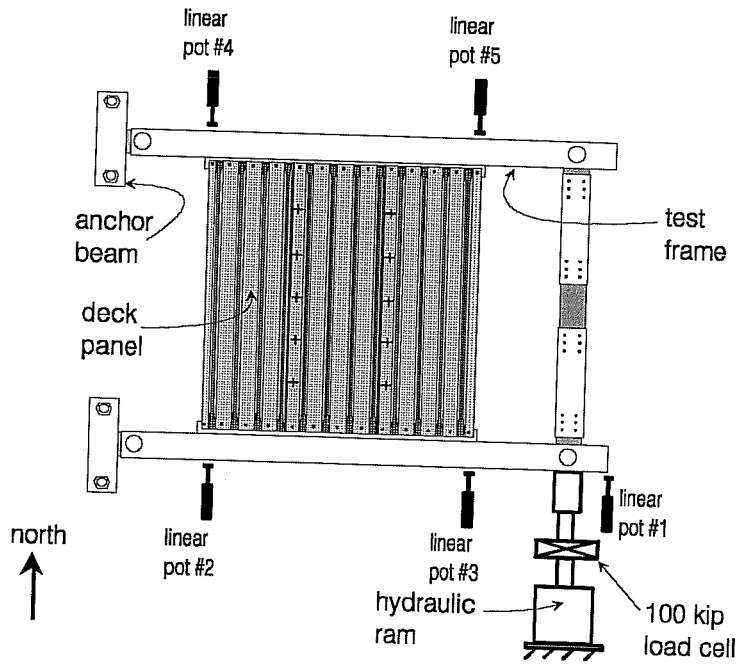

Figure 3.5 Instrumentation of test frame.

3.3 Instrumentation

Instrumentation of the test frame, which is located as shown in Figure 3.5, consisted of the following:

- The load, applied through a hydraulic ram at the end of the south support beam, was measured using a commercial load cell. The load cell was calibrated prior to testing and, based on two independent checks, measured the applied load to within 2% accuracy. The output from the load cell was collected by a computerized data acquisition system.
- Lateral movement of the support beams was measured by five linear potentiometers located at the level of the edge of the 1" x 18" plate. Movement was measured at the end of the south support beam and near each of the corners of the deck test panel, thereby providing five redundant measurements of shear deflection for comparison and averaging. The data from these linear potentiometers and all other linear potentiometers was also collected by the data acquisition system.
- Additional potentiometers, not shown in Figure 3.5, were located six inches directly below each of the linear potentiometers at the panel corners described above. Combined data from these pairs of potentiometers was used to determine whether or not the support beams were experiencing any cross sectional rotation (tipping) during the tests. Test data indicated that this tipping was insignificant throughout all of the tests.

3.4 Deck Attachment

3.4.1 Rigid Connection. The primary objective of this study was to determine the shear stiffness of the deck panels singularly, without any detractors from the deck support system. For this reason, a rigid connection between the deck panel and the support beams was used for the majority of the tests. To accomplish this connection, deck panels spanning between the two deck support beams were fastened to standard deck support angles rigidly attached to each of the deck support beams. At each deck support beam a standard deck support angle was welded to the bottom of the 1" by 18" plate using a continuous 1/8" fillet weld the full length of the support angle. This standard deck support angle was a galvanized angle 3" x 2" x 8 gage for all tests. The connection is shown in Figure 3.6.

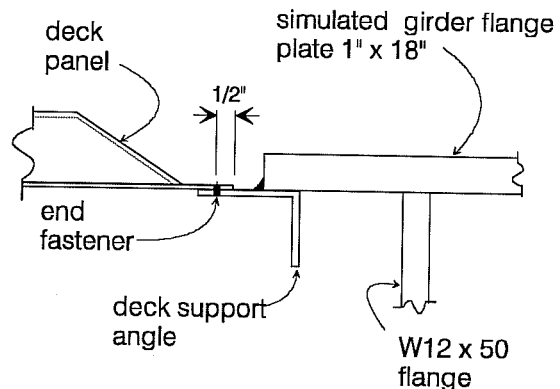

Figure 3.6 Rigid connection of deck support angle to simulated girder flange.

The deck panel ends were screwed to the support angles using 1/4" x 1-1/8" TEKS screws, with particular attention given to insuring that a distance of 1/2" from screw centerline to the end edge

of the deck panel was achieved. These end fasteners were installed using a Hilti Model TKT2000 (0 to 2080 rpm) adjustable screw gun set at a setting determined to be sufficient to draw the deck snug against the support angle and at the same time eliminate over-torquing the screw and twisting off the head. In addition to the end fasteners, 1/4" TEKS screws were used to connect the lap seams between individual deck sheets. Side lap fasteners were installed with the same screw gun set at a lower setting. This lower torque level was needed to prevent stripping out the light gage materials at the lap connections and varied with the thickness of the deck sheets. Spacing of the end fasteners and side lap fasteners is detailed in chapter four of this report.

3.4.2 Welded Angle Eccentric Connection. It is common practice, when welding to the plate girder flange is permitted, to weld the deck support angles to the girder top flange as discussed in section 1.8 and shown in Figure 1.9. To simulate this attachment, a standard deck support angle was welded to the 1" plate using 1/8" x 1-1/2" fillet welds at 12" on center the full length of the support angle. The support angle was positioned with the deck bearing surface 2-3/8" below the top of the 1" plate, as shown in Figure 3.7, in order to produce the largest eccentricity possible using this particular support angle. A galvanized 3" x 2" x 8 gage angle was once again used as the support angle.

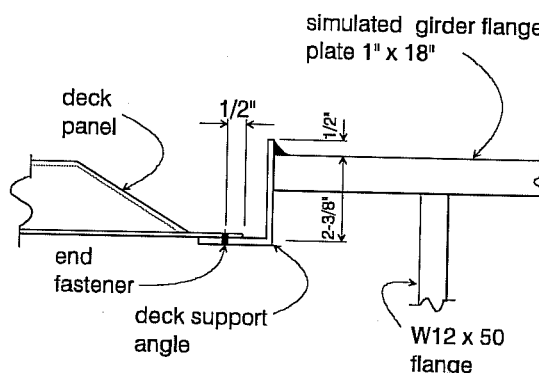

Figure 3.7 Welded eccentric connection of deck support angle to simulated girder flange.

Deck panels were fastened to the deck support angles using the same procedure as described above for the rigid connection tests.

3.4.3 Strap Angle Eccentric Connection. Simulation of the deck support angle attachment used when welding to the girder is not permitted was accomplished as illustrated in Figures 3.8 and 3.9.

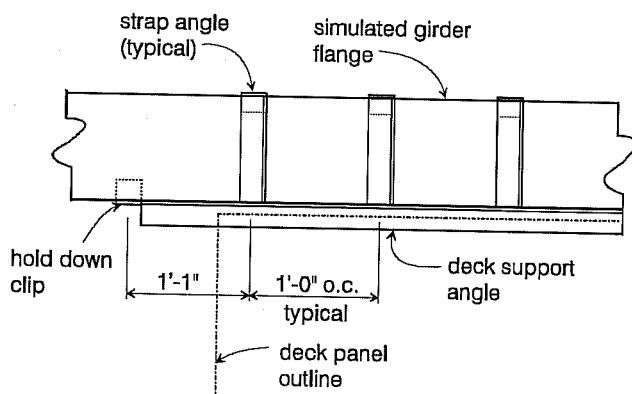

Figure 3.8 Plan of strap angles and deck support angle for non-welded connection.

The deck support angle was welded to the strap angle only and not to the 1" plate. The strap angle was held in place by a 2" long clip angle. Neither the strap angle nor the clip angle was welded to the 1" plate. The strap angles were spaced at 12" on center over the length of the deck support angle except at the ends where hold down clips were used. Once again the deck support angle was positioned with the deck bearing surface located 2-3/8" below the top of the 1" plate. Galvanized 3" x 2" x 8 gage angles were used for the deck support angles, strap angles and clip angles and the deck panels were attached in the

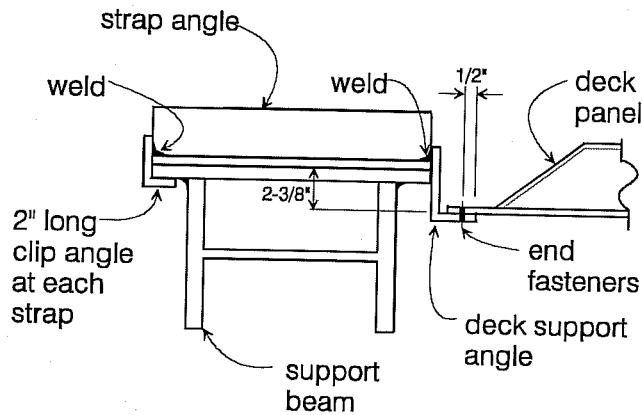

Figure 3.9 Non-welded eccentric connection of deck support angle to simulated girder flange.

same manner as the other methods of attachment.

This strap angle arrangement simulates a fascia girder attachment where removable cantilever forms are used on the outboard side of the girder.

3.5 Test Procedure

Two separate sets of cyclical loadings were conducted for each test. The first set of cycles was conducted on deck panels with no additional applied vertical load. This set of cycles was performed to determine the stiffness of the deck panels in a condition free of all loads except for the in-plane lateral loads. These tests are referred to as "unloaded" tests.

Upon completion of this first set of cycles, another set of cycles was executed with an 80 psf uniform dead load applied in addition to the in-plane lateral loads. Figure 3.10 shows the arrangement of concrete blocks simulating this uniformly distributed load, which would be approximately equal to the weight of a 6 inch slab of normal weight concrete. This second set of cycles, referred to as "loaded", was conducted to determine if out-of-plane loading had any effect on the shear stiffness of the deck panels. The final cycle of the "loaded" portion of the tests involved application of the in-plane lateral load until an ultimate limit state was reached or exceeded.

To begin each test, the test frame was moved into a squared position and the deck panels were attached to the deck support angles. The hydraulic ram was also relieved of any pressure to insure that no load existed in the load cell prior to the test. All linear potentiometers were positioned and their positions along the support beams were recorded. The position of the deck panel with respect to the support beam pivot points was also recorded. A thorough housecleaning and inspection was done at each pin assembly and caster to insure that no foreign particles were present which might inhibit the frame's movement. The load cell voltage amplifiers were reset and trimmed to a zero output and the shunt calibration values were checked and recorded. The data acquisition system was then activated and all initial data points were recorded and the system was zeroed. Prior to zeroing the system, several scans were taken to insure that none of the instruments were experiencing any unreasonable output fluctuations. If any fluctuations were discovered, the problem instruments were replaced and rechecked. Finally, the caster wheels were checked to make sure that their alignments were in the direction of frame travel.

The "unloaded" set of cycles consisted of the following:

- Cycle 1 - application of lateral load in the south direction up to a maximum load of 1.0 kip and return of this load back to a zero load reading.

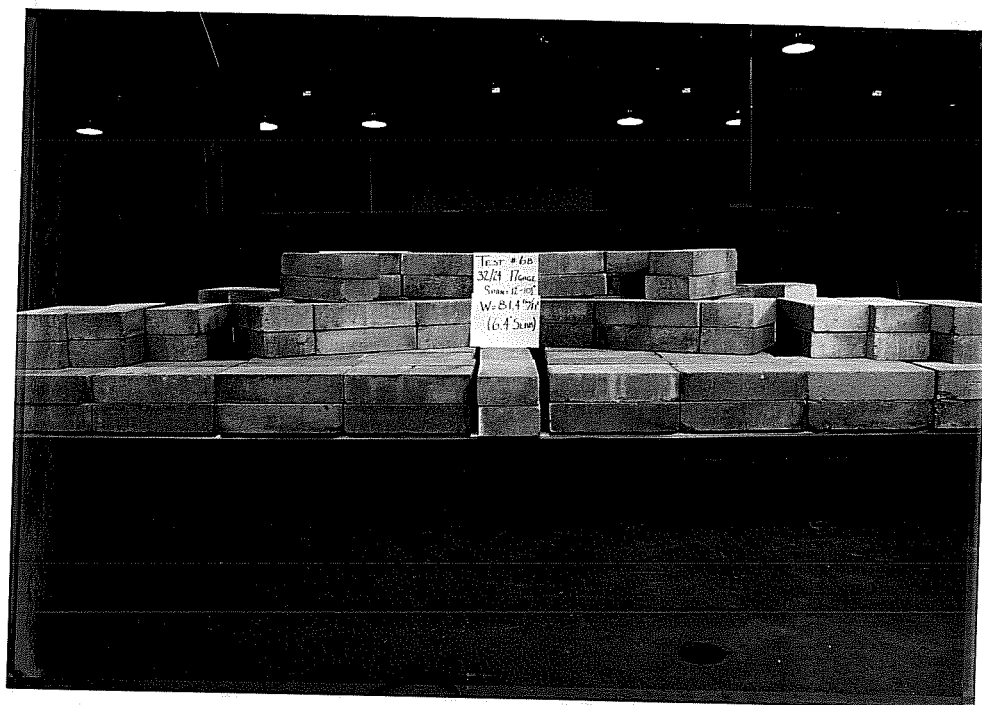

Figure 3.10 Simulation of 80 psf dead load with concrete blocks.

- Cycle 2 - application of lateral load in the north direction to 1.0 kip, reversing the load direction and continuing in the south direction through zero load to a load of 1.0 kip, reversing the direction of the load again and returning to a zero load reading.
- Cycle 3 - same as cycle 2.
- Cycle 4 - same as cycle 1.
- Cycle 5 - same as cycle 1.
- Cycle 6 - same as cycle 2.

At the completion of these six cycles, the frame was checked to insure that it was once again in a square configuration with no load remaining in the load system. Dead load concrete blocks were placed on the deck panels similar to those shown in Figure 3.10. Once again, a thorough housecleaning was done and all linear potentiometers were checked for correct location and freedom of movement. The load cell voltage amplifiers were reset and trimmed to a zero output and the shunt calibration values were checked and recorded. The data acquisition system was rezeroed and the caster wheels were checked for alignment.

Elevations at several points on the deck panel and support angles were recorded both prior to and after the placing of the concrete blocks to determine the deflection of the deck and support angles due to the addition of the uniform load on the deck.

The "loaded" set of cycles consisted of the following:

- Cycle 1 - application of lateral load in the south direction up to a maximum load of 1.5 kips and return of this load back to a zero load reading.
- Cycle 2 - application of lateral load in the north direction to 1.5 kips, reversing the load direction and continuing in the south direction through zero load to a load of 1.5 kips, reversing the direction of the load again and returning to a zero load reading.
- Cycle 3 - same as cycle 2.
- Cycle 4 - same as cycle 1.
- Cycle 5 - same as cycle 1.
- Cycle 6 - same as cycle 2.
- Cycle 7 - application of lateral load in the south direction up to or beyond a limit state, such as fracture of an end fastener or substantial bearing deformation at the end fasteners.

The lateral load was applied by a hydraulic cylinder which was controlled with a hand pump. The load was applied at a rate of approximately 0.2 kips/minute through the elastic portion of the test with a continuing uniform strain rate thereafter. The load was monitored during the test with a multimeter connected to the load cell amplifier. Data readings were taken at 50 pound load intervals during the first two cycles of each set of tests and at 100 pound intervals during the remaining cycles. An X-Y plotter was also used to monitor the applied load versus the southeast linear potentiometer (l.p. #3 in figure 3.5) during the tests.

Upon completion of the loaded tests, the deck panels were inspected for any visible screw failures, deck bearing deformation or any other deck deformations. The screws were removed and a record was made of all screw failure locations, amount of bearing deformation at the end fasteners and any deck deformation at the side lap seams. Two material specimens were obtained from each type of deck for the purpose of determining the actual material properties of the deck.

Raw voltage data, collected by the data acquisition system during each test, was converted to displacement and load units for use in a commercial computer spreadsheet.

3.6 Frame Friction Tests

The internal friction of the test frame was checked several times during the testing program. These tests consisted of measuring the loads required to displace the test frame without any deck panel present. Tests were conducted with the test frame acting under its own weight alone and also with the support beams loaded with a dead load that was equivalent to the 80 psf dead load for its corresponding panel width and span.

Results of these tests indicated that a lateral load of approximately 32 pounds was required to produce movement in the unloaded frame. With the application of dead load, it was determined that 0.0066 pounds of additional lateral force was required to move the frame for each pound of dead load added.

Shear stiffnesses and strengths reported in the following sections are the measured test values with the frame friction removed.

CHAPTER 4

TEST RESULTS

4.1 Overview

This chapter presents the results of the shear strength and shear stiffness tests performed on both the open and flat soffit deck profiles. Results reported include values for unloaded shear stiffness, loaded shear stiffness and deck panel shear strength along with load-deflection curves demonstrating ductility of failure.

The calculations of these values for deck profile type BUBF18 are presented in the subsections below as examples of the computational methods used throughout the study. Values for all deck profile types, computed using these methods, are presented in tabular form in Section 4.2.

4.1.1 Unloaded Shear Stiffness.

Each deck profile type was tested free of any out-of-plane dead load as described in Chapter 3. These tests are referred to as unloaded and included several cycles of lateral loading also described in Chapter 3. Figure 4.1 presents a plot of shear load versus shear strain for a complete set of cycles conducted on deck test specimen BUBF18 with no dead load present.

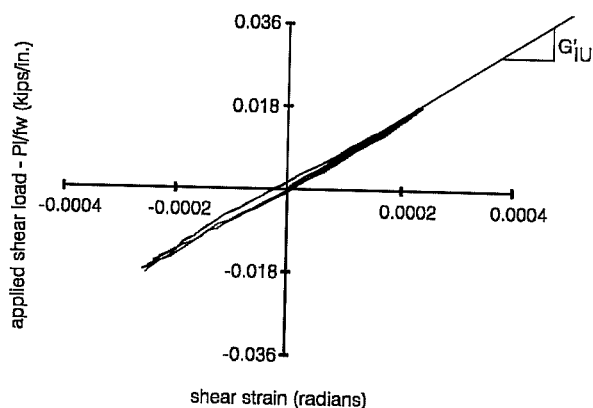

Figure 4.1 Shear load vs. shear strain - all unloaded cycles.

The initial unloaded shear stiffness, G'_{IU} , was determined from the initial cycle of each unloaded test (cycle 1) and is reported in the following sections as the unloaded shear stiffness. These stiffness values were calculated using the formulation for G' in Equation 1.6-1 and used shear strain values at maximum first cycle lateral load (approx. 1 kip) for the calculations. It should be noted that throughout this study lateral loads have been reduced by the test frame friction values presented in Chapter 3. Calculation of G'_{IU} for specimen BUBF18 proceeds as follows:

Lateral Load (P)	= .98 kips
Frame Length (l)	= 216 inches
Frame Width (f)	= 116.75 inches
Deck Panel Width (w)	= 104 inches
Shear Strain (γ)	= 0.000232
$G'_{IU} = Pl / fw\gamma$	= 75 kips/inch

In addition, incremental shear stiffnesses were calculated using differential shear strains and their corresponding differential shear loads from one lateral load value to the next. These incremental

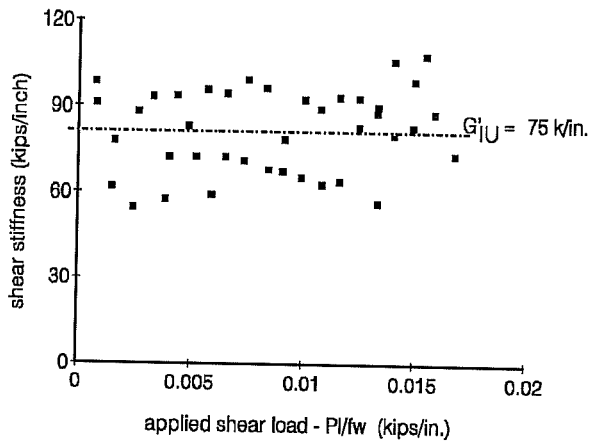

Figure 4.2 Comparison of initial cycle stiffness to incremental stiffnesses.

load and displacement steps. It was found that for each deck specimen the average of the incremental unloaded shear stiffnesses compared favorably with their corresponding initial shear stiffness for all lateral loading cycles and, therefore, only the initial unloaded shear stiffnesses are reported.

The loading cycles for the unloaded configurations were all limited to the elastic range of both the deck and deck fasteners and consequently no failure characteristics are presented.

4.1.2 Loaded Shear Stiffness. Tests were also conducted on all deck profile types with an 80 psf out-of-plane dead load present. These loaded tests also included several cycles of lateral loading and are described in Chapter 3. The shear stiffness for these loaded tests was determined using three independent methods.

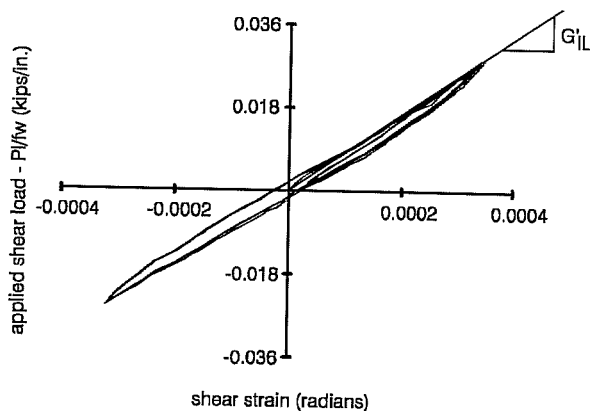

Figure 4.3 Shear load vs. shear strain - all loaded cycles except ultimate cycle.

unloaded shear stiffnesses were then plotted versus their corresponding shear load values for all cycles of lateral loading.

The computed initial unloaded shear stiffness value, G'_{IU} , was compared to the plot of incremental shear stiffnesses for the initial loading cycle to confirm the computed initial stiffness. The computed initial shear stiffness value was also compared to the plot of subsequent cycles of incremental stiffnesses to verify that the deck stiffness did not change substantially under cyclical loading. Figure 4.2 shows a typical comparison of initial unloaded shear stiffness to a related plot of incremental stiffnesses. The variation in the incremental stiffness shown in Figure 4.2 is not unexpected. The experimental error is larger for these small

The first method was similar to that used for the unloaded tests in that the stiffness was determined from the initial cycle of lateral loading (first lateral loading cycle performed with the 80 psf dead load in place) and used the shear strain at maximum first cycle lateral load (approx. 1.5 kips) in the computation of the stiffness. This load of 1.5 kips was chosen as the maximum cycle load to insure that the cyclical loading remained in the elastic range of both the deck and deck fasteners. Figure 4.3 presents a plot of shear load versus shear strain for the cyclical loading performed on deck test specimen BUBF18 with an 80 psf dead load present. All loading cycles are shown in Figure 4.3

except the ultimate loading cycle. Results of the calculation of the initial loaded shear stiffness, G'_{IL} , for the test using specimen BUBF18 are presented below as a typical example:

Lateral Load (P)	=	1.44 kips
Frame Length (l)	=	216 inches
Frame Width (f)	=	116.75 inches
Deck Panel Width (w)	=	104 inches
Shear Strain (γ)	=	0.000331
$G'_{IL} = Pl / fw\gamma$	=	77 kips/inch

Incremental shear stiffnesses were also plotted as a function of applied shear load for the decks with 80 psf dead load for all cycles of loading. Once again, comparison of initial loaded shear stiffness values and incremental loaded shear stiffnesses showed a close correlation for all tests and consequently only the initial loaded shear stiffness, G'_{IL} , will be presented.

A third method was used to determine the shear stiffness of the loaded decks. This method, recommended by the Steel Deck Institute⁴, utilized data from the final cycle of lateral loading, where the lateral load was increased until a limit state was reached. Shear stiffness $G'_{.4P_{ult}}$ is defined relative to the slope of the shear load vs. shear strain curve through $.4 S_{ult}$, where S_{ult} is the maximum applied shear load at failure. Figure 4.4 presents the shear load versus shear strain curve for all cycles of lateral loading up to and including the final cycle for deck test specimen BUBF18 with an 80 psf dead load. Shear stiffness $G'_{.4P_{ult}}$ was determined using the formulation presented in Chapter 1 and the values of applied shear load and shear strain observed at $.4 P_{ult}$. For specimen BUBF18 the resulting $G'_{.4P_{ult}}$ is:

Lateral Load ($P = .4P_{ult}$)	=	3.13 kips
Frame Length (l)	=	216 inches
Frame Width (f)	=	116.75 inches
Deck Panel Width (w)	=	104 inches
Shear Strain (γ)	=	0.00077
$G'_{.4P_{ult}} = Pl / fw\gamma$	=	72 kips/inch

It should be noted that values of G' obtained using the $.4 P_{ult}$ method are generally conservative when compared to the values extracted from the initial cycle of the loaded tests. This comparison is shown in Figure 4.4.

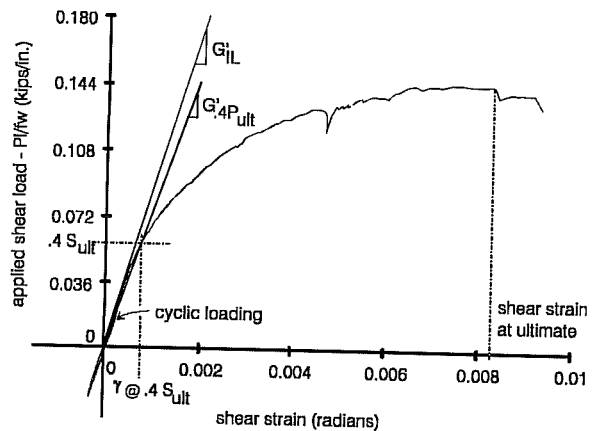

Figure 4.4 Shear load vs. shear strain - all loaded cycles.

4.1.3 Deck Panel Shear Strength. The diaphragm shear strength (S_{avg}) of a deck panel was defined in Chapter 1 as the average shear along the fastened panel edge at failure. The calculation of the diaphragm shear strength of specimen BUBF18 is shown below as a typical example of how shear strength values were determined:

Lateral Load ($P=P_{ult}$)	=	7.98 kips
Frame Length (l)	=	216 inches
Frame Width (f)	=	116.75 inches
Deck Panel Width (w)	=	104 inches
$S_{avg} = (Pl/f)/w$	=	0.142 kips/inch

The diaphragm shear strength S_{avg} above is also presented in the results tabulated later in this chapter as a function of the number of end fasteners in the panel. The quantity $S_{avg}/\text{Fastener}$ is defined as the diaphragm shear strength divided by the total number of end fasteners along one end of the deck panel. For the BUBF18 specimen this value is:

$$S_{avg} / \text{fastener} = .142 / 17 = 0.0084 \quad (\text{kips/in}) / \text{fastener}$$

4.1.4 Ductility of Failure. Lateral loading, of all tests involving fully fastened deck panels, was continued until a fastener fracture or extreme bearing deformation at a fastener occurred. This was done to obtain a clear indication of whether the deck panel responded in a ductile or non-ductile manner.

The ductility of a particular deck panel system is most clearly demonstrated by the load-deflection curve generated during the ultimate load cycle of the deck panel test. Figure 4.5 presents the shear load vs. shear strain curve for the BUBF18 deck profile specimen. This curve, which exhibits a well defined plastic plateau, indicates a reasonably ductile failure response.

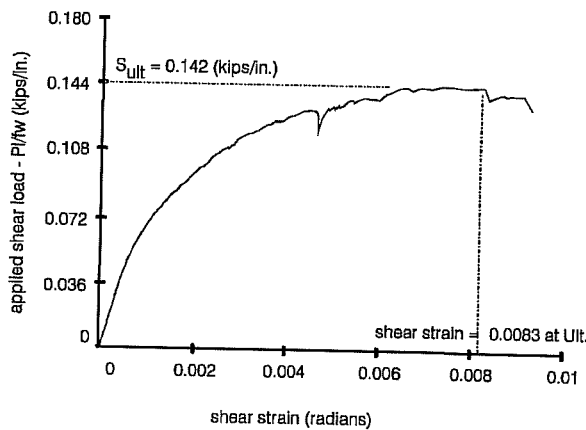

Figure 4.5 Shear load vs. shear strain - ultimate cycle.

Noticeable dips in the load-deflection curve are locations where the rate of loading was stopped momentarily and a slight drop off in load occurred. The rate of loading was held at approximately two hundred pounds per minute.

4.1.5 Midspan Deck Deflections. Midspan deflections, under the 80 psf dead load, were measured and compared to the theoretical deflections expected for these loads. Measured deflections were generally found to be within 20 percent of the theoretical values for the tests conducted using the rigid support detail. Deflections

observed for the tests with the non-rigid support details, however, were approximately 40 percent higher than the expected values.

4.2 Deck Tests Results

The primary goal of this study was to determine the shear strength and shear stiffness characteristics of various deck profile types and the effect that the end and side lap fasteners have on these properties. As was stated earlier, it was intended that the strength and stiffness values be determined without any contribution from the method of deck support. All tests, unless noted otherwise, were conducted using a rigid support angle connection, described in Chapter 3, in order to eliminate any deck support member influence.

In order to determine the effect that end and side lap fasteners have on shear strength and stiffness, tests were conducted on all deck types using two basic fastener configurations. These configurations will be referred to as the "standard" configuration and the "fully fastened" configuration. The standard configuration, recommended by the deck manufacturers for their specific decks, consists basically of end fasteners in alternate end rib troughs and limited side lap fasteners. The fully fastened configuration consists of end fasteners in every rib trough and more closely spaced side lap fasteners. It should be noted that for the LSM type decks the standard configuration and the fully fastened configuration are identical. These tests were conducted using test panels that were approximately 8 feet wide (actual panel widths were a multiple of individual sheet coverages as described in Chapter 2). The results of "standard" and "fully fastened" tests, all utilizing a rigid support angle, are presented in section 4.2.1.

Section 4.2.2 presents results of tests on deck panels 8 feet wide utilizing various combinations of standard and fully fastened ends and side laps for two types of deck profiles (BUBF18 and BOSW18). The effects of missing side lap fasteners and missing end fasteners, for 8 foot wide panels, are given in section 4.2.3. Panel widths of 12 feet are considered in section 4.2.4. Again, the test results presented in Sections 4.2.2, 4.2.3 and 4.2.4 were obtained from tests using a rigid support angle configuration.

Several pilot tests were conducted to determine the effect of deck support methods on the shear stiffness of the deck/girder system. Results of these tests are presented in Section 4.2.5.

Finally, Section 4.2.6 presents the results of a pilot test which utilized powder actuated fasteners in place of TEKS screws at the end fasteners.

4.2.1 Standard and Fully Fastened Configurations. Each open profile deck type and each flat soffit profile deck type, identified in Chapter 2, was tested in an 8 foot panel width using both the standard fastener configuration and the fully fastened configuration. Table 4.1 presents the results of these tests. Standard and fully fastened configurations for each deck profile type are shown in Figures 4.6 through 4.10.

All tests using a standard fastener configuration were conducted free of any out-of-plane dead load (unloaded) and, therefore, only unloaded shear stiffnesses are presented in Table 4.1 for the

Table 4.1 Test results for 8' wide panels with standard and fully fastened configurations.

Deck Type	Span (feet)	Gage	Pitch (inches)	Grade	Depth (inches)	Unloaded			Loaded			
						Standard Fasteners G'_{IU} (kips/in)	Fully Fastened G'_{IU} (kips/in)	Fully Fastened G'_{IL} (kips/in)	Fully Fastened $G'_{.4P_{ult}}$ (kips/in)	Fully Fastened S_{avg} (kips/in)	Fully Fastened $S_{avg}/Fastener$ (kips/in/fast.)	
BUBF18	8'-0"	18	6.5	E	2.5	39	75	77	72	0.142	0.0084	
BUBF16	7'-9"	16	6	E	2	45	83	94	82	0.172	0.0101	
BUBF14	8'-6"	14	6.5	E	2.5	58	99	98	88	0.156	0.0092	
BOS816	10'-0"	16	8	C	3	43	59	59	54	0.103	0.0079	
BOSW18	8'-0"	18	8	C	2.5	31	60	70	66	0.109	0.0084	
BO8.5P	7'-8"	16	8.5	C	2	49	93	95	94	0.133	0.0102	
LSM1516	12'-10"	15	8 & 8	C	4.5	63	63	65	59	0.095	0.0079	
LSM1524	12'-10"	15	8 & 16	C	4.5	38	38	42	41	0.076	0.0095	
LSM1716	12'-10"	17	8 & 8	C	4.5	50	50	55	42	0.108	0.0090	
LSM1724	12'-10"	17	8 & 16	C	4.5	31	31	40	37	0.069	0.0086	
LSM2216	8'-11 1/2"	22	8 & 8	E	4.5	21	21	24	26	0.074	0.0062	
LSM2224	8'-11 1/2"	22	8 & 16	E	4.5	13	13	20 ^a	21	0.050	0.0063	

a - G'_{IL} for LSM2224 was evaluated at approximately 1 kip lateral load due to the fact that $.4P_{ult}$ occurs at a lateral load smaller than 1.5 kips

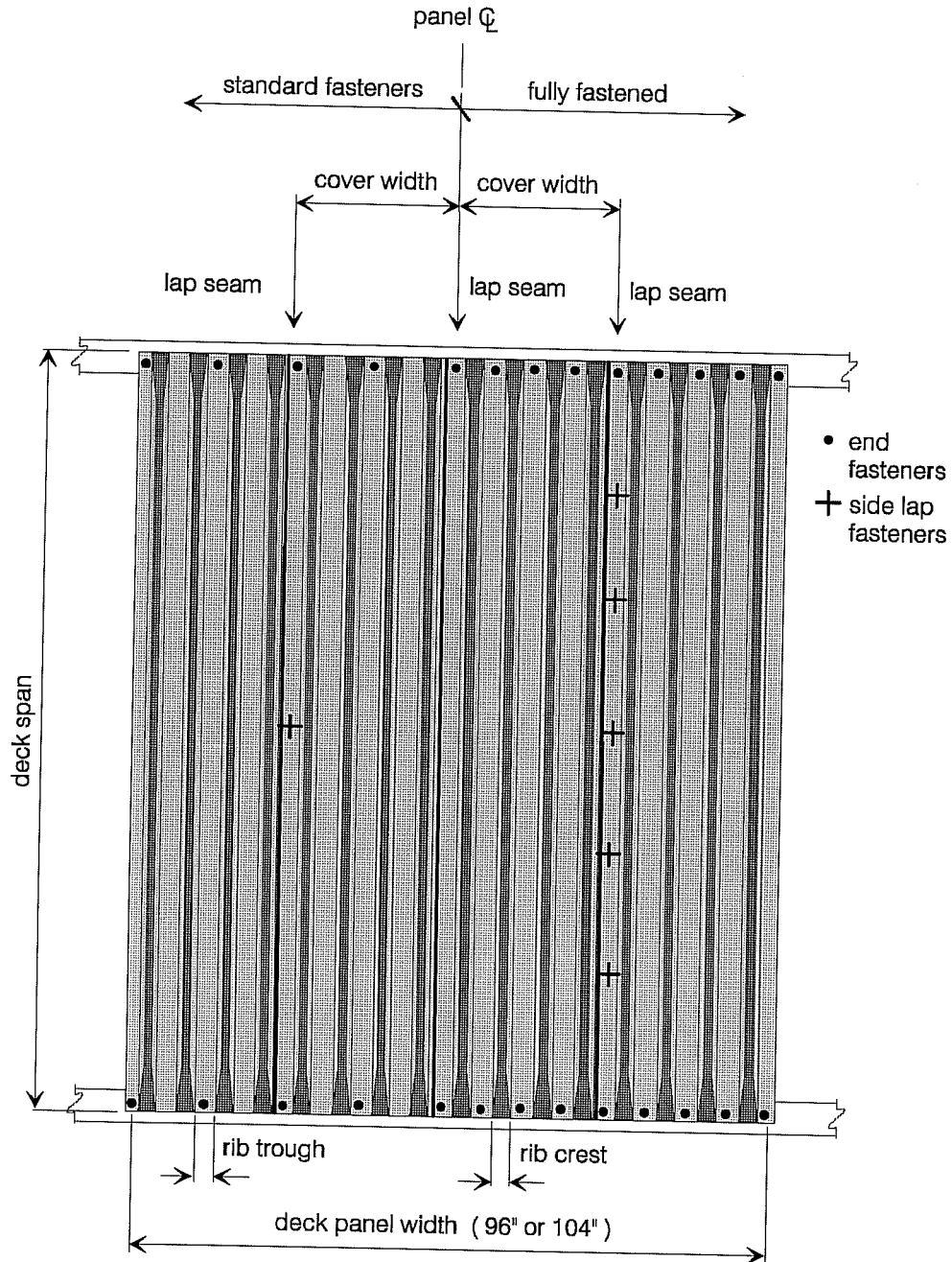

Figure 4.6 Fastener configurations - deck types BUBF18, BUBf16, and BUBF14.

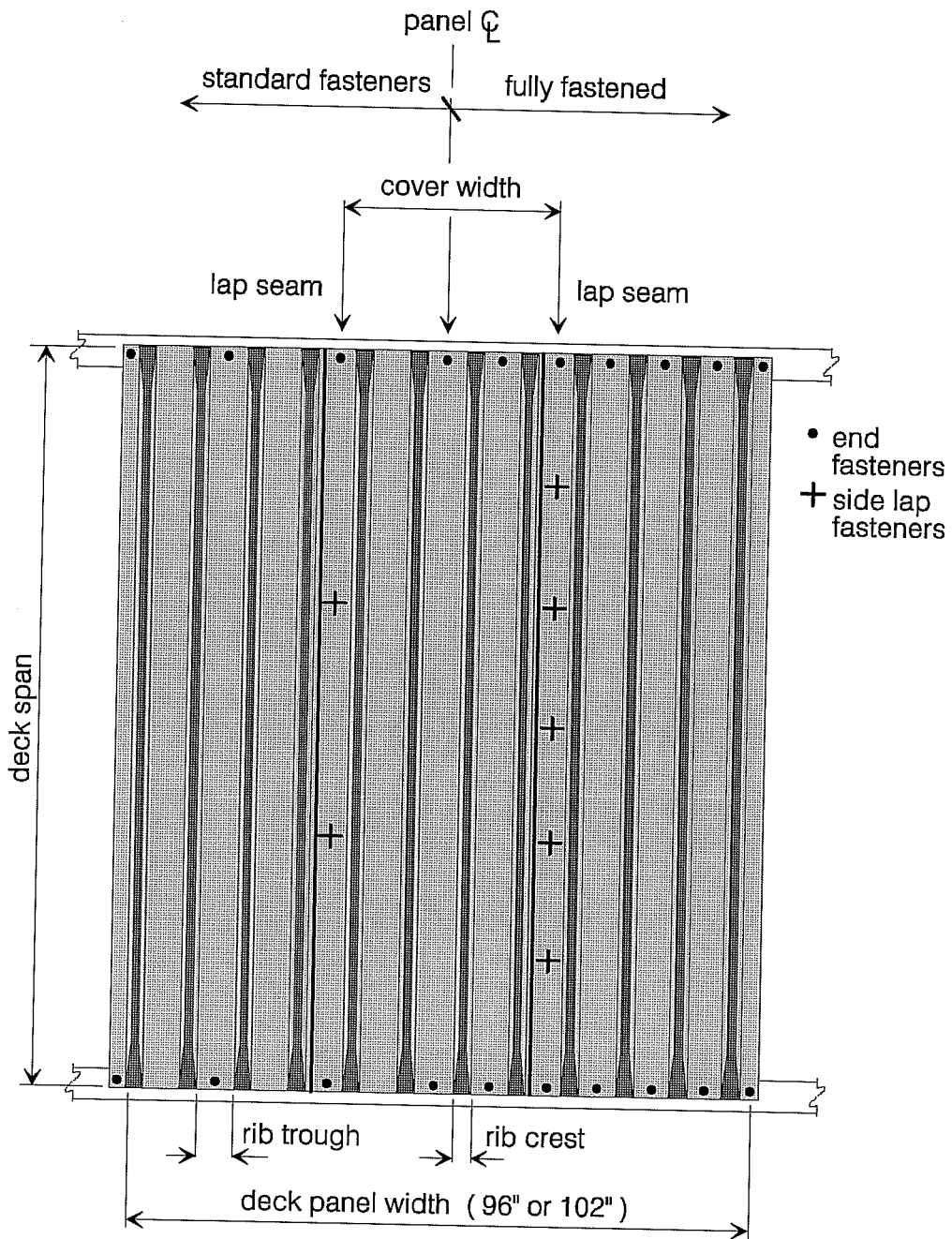

Figure 4.7 Fastener configurations - deck types BOSW18 and BO8.5P.

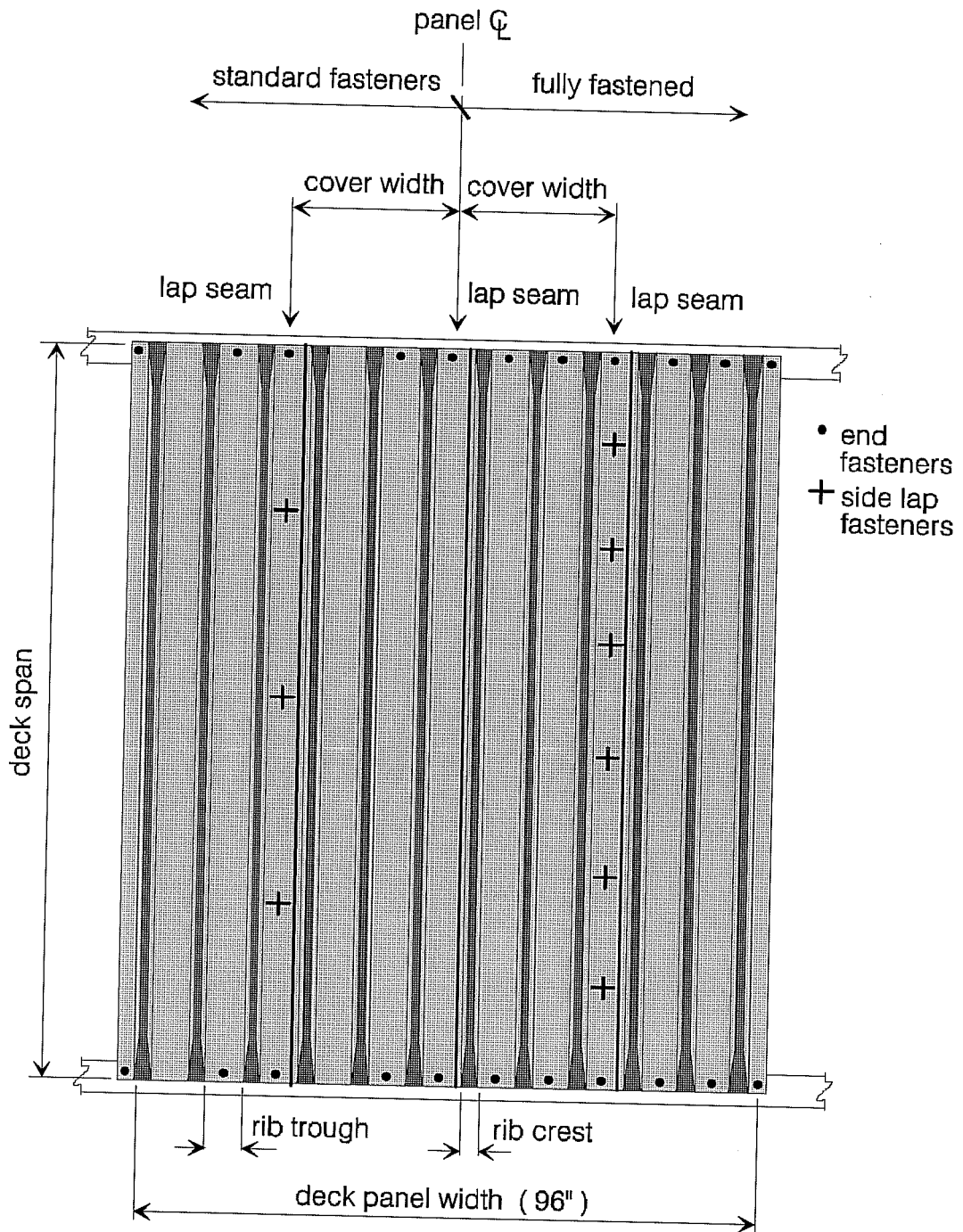

Figure 4.8 Fastener configuration - deck type BOS816.

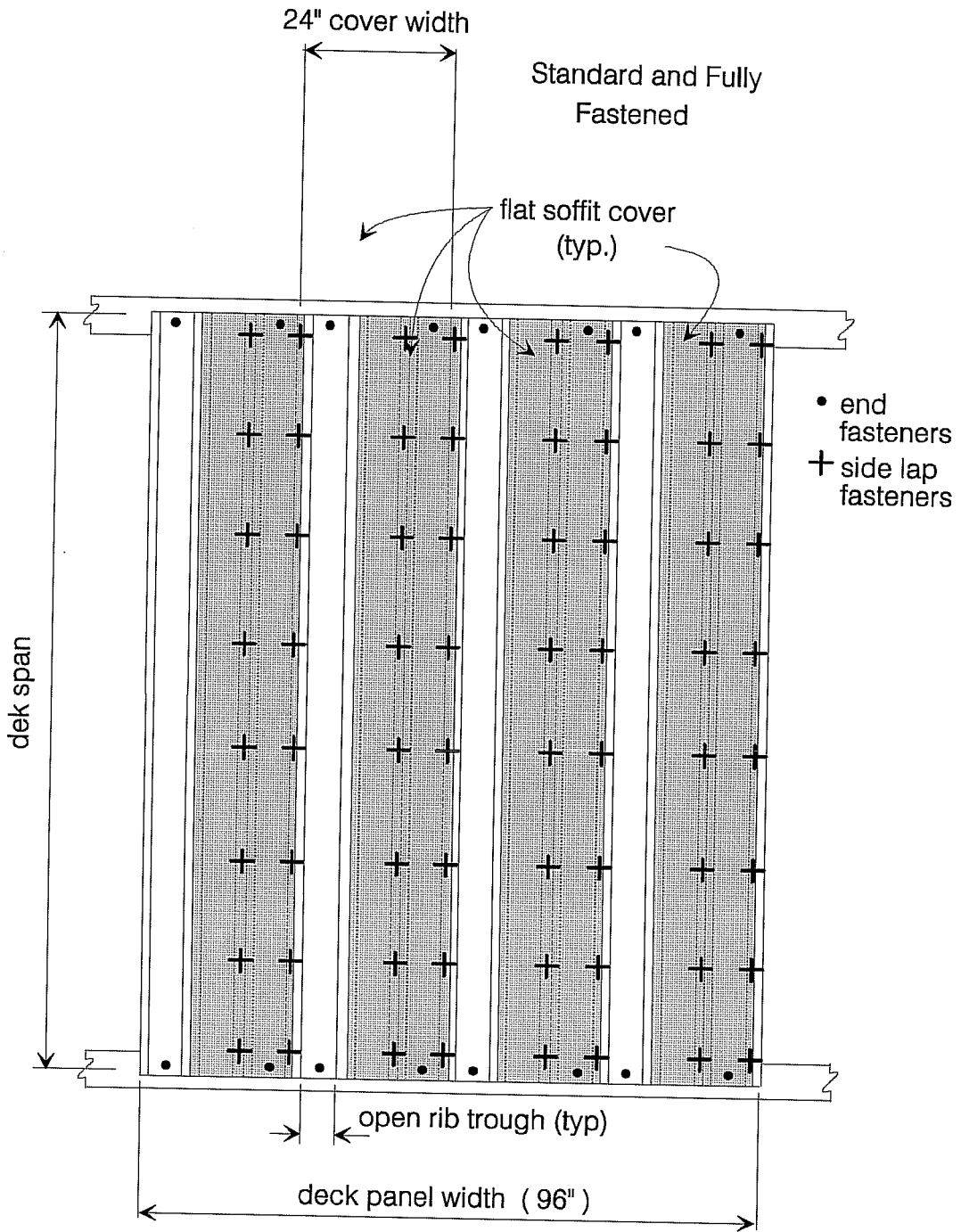

Figure 4.9 Fastener configurations - deck types LSM1524, LSM1724, and LSM 2224.

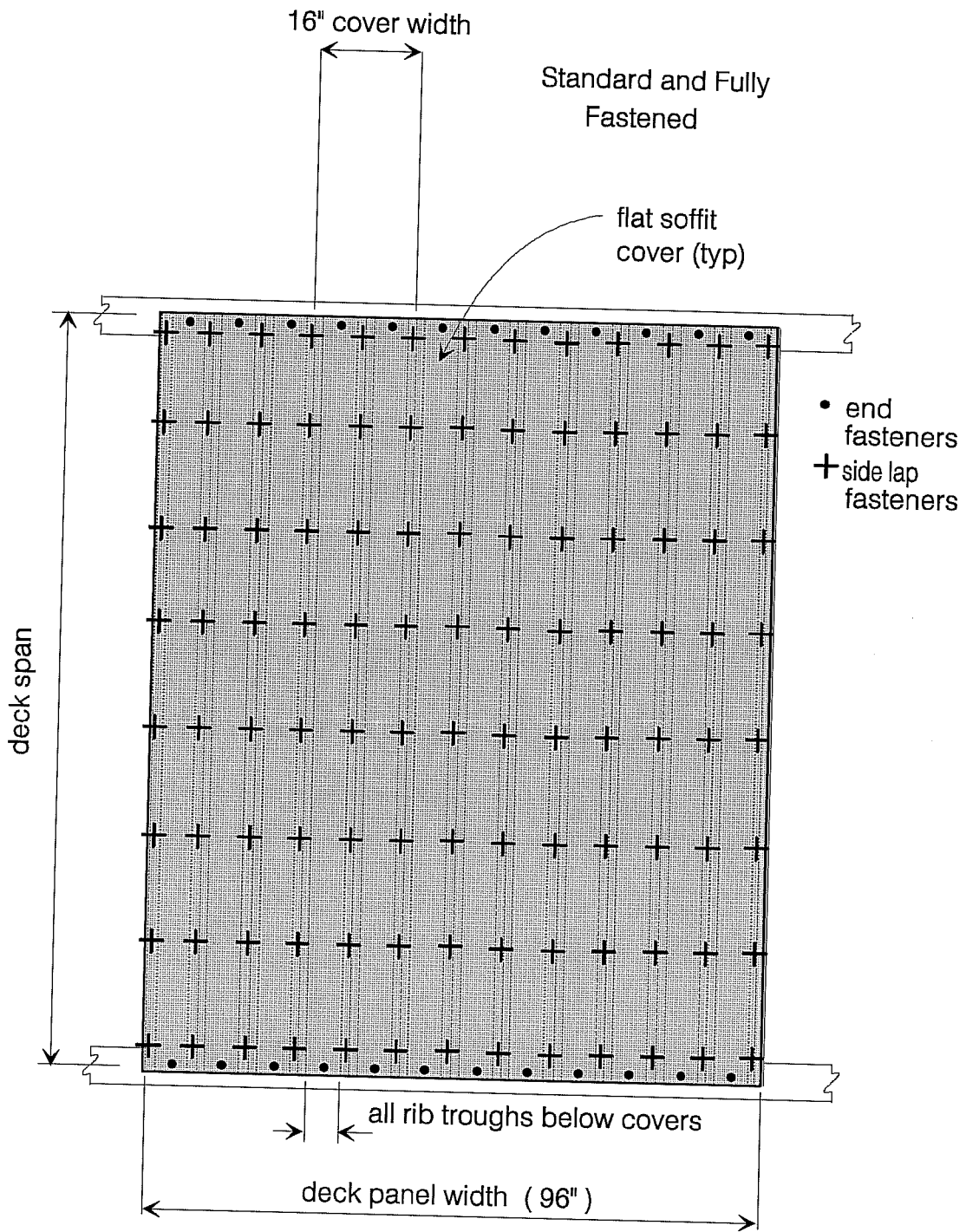

Figure 4.10 Fastener configurations - deck types LSM1516, LSM1716 and LSM2216.

standard fastener configuration tests. In order to maximize the usage of the available deck, tests on decks utilizing standard fastener configurations were conducted entirely within the elastic range of the deck material and fasteners. These deck panels were then re-used for the fully fastened tests.

Tests of fully fastened deck panels were also carried out on 8 foot wide panels for all the various deck profile types. These tests were conducted in both the unloaded and loaded (80 psf dead load) configurations.

Once again the fully fastened unloaded deck panel tests were conducted in the elastic range of the deck systems, therefore, only initial cycle shear stiffness, G_{IU} , is presented.

Tests in the fully fastened loaded configuration (with 80 psf out-of-plane dead load) were loaded laterally until a limit state was reached. This limit state was either a fracture of a deck fastener or sufficient bearing deformation at a deck fastener, or fasteners, that caused a noticeable decrease in the deck's capability to sustain the lateral load. Table 4.1 presents the values of unloaded shear stiffness, loaded shear stiffness (both first cycle and $.4 P_{ult}$ methods of computation) and deck panel shear strength for all fully fastened deck profile types.

Results of the LSM2224 deck test, shown in Table 4.1, show a large difference between the unloaded and loaded shear stiffnesses. To confirm these results, a second test was conducted on another panel of the LSM2224 deck type. This test was conducted after all other tests were complete and produced the same results as the initial LSM2224 test.

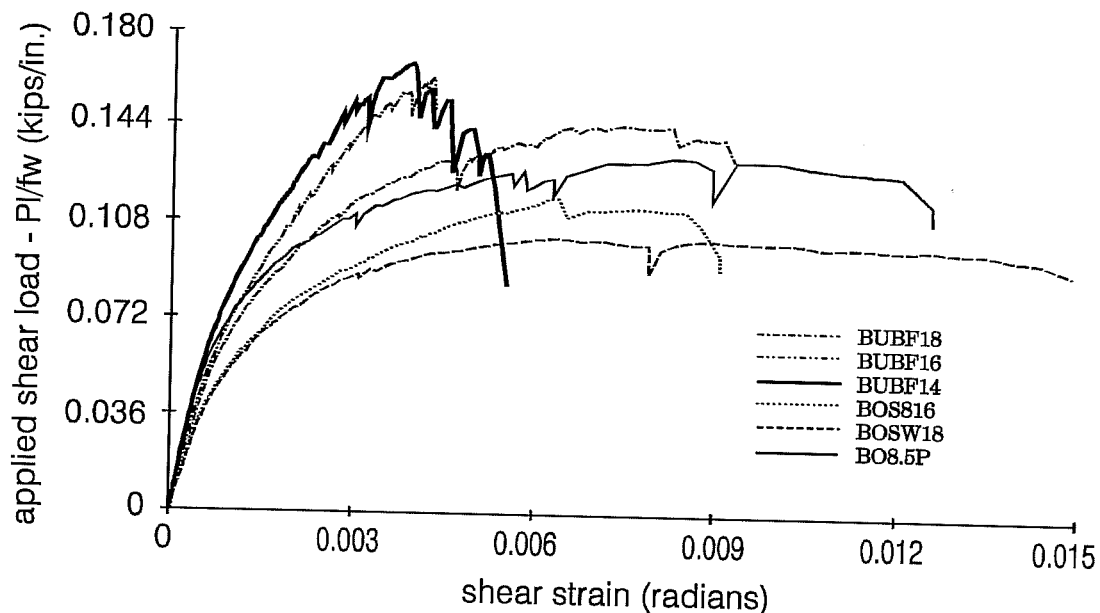

Figure 4.11 Shear load vs. shear strain - ultimate cycles for open profile decks.

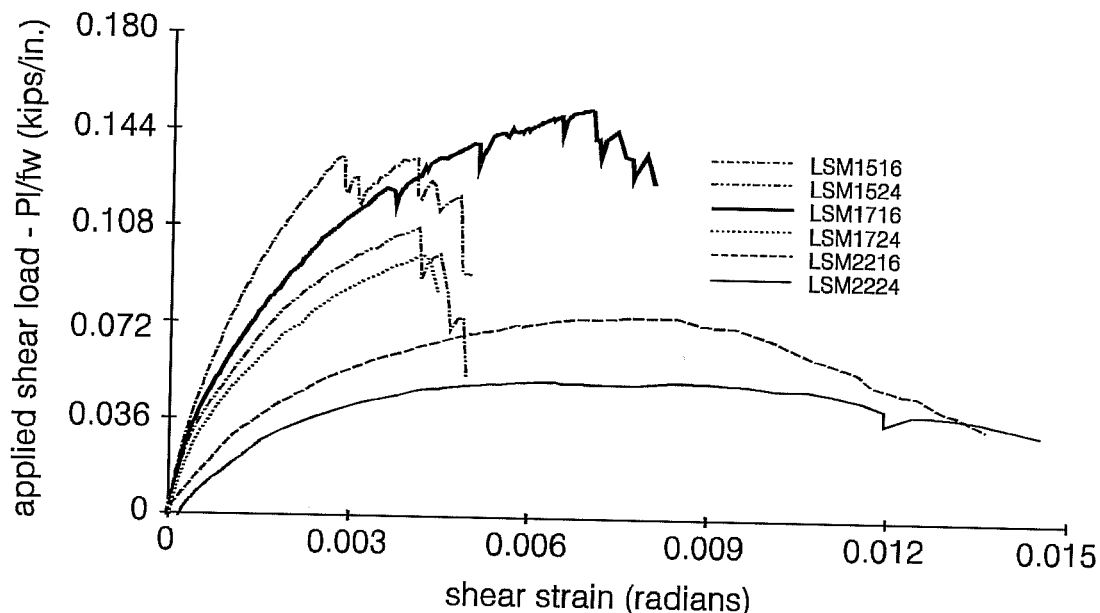

Figure 4.12 Shear load vs. shear strain - ultimate cycles for flat soffit profile decks.

Figures 4.11 and 4.12 display the plots of applied shear load vs. shear strain for the various deck profiles tested to failure in the fully fastened configuration. These plots provide an indication of the ductility of the deck panel system to failure.

All tests represented in Table 4.1 were conducted using a rigid support angle.

4.2.2 Standard/Full Fastener Combinations. Two deck profiles were tested to examine the variation in deck stiffness capacities as a function of combinations of standard or full fastener configurations at the end and side lap fasteners. Buffalo Bridgeform deck forms (BUBF18) and Bowman Strongweb deck forms (BOSW18) were tested under the four possible combinations of end and side lap fastener configurations and the results are presented in Table 4.2. These tests were conducted on deck panels 8 feet wide in the unloaded configuration and also utilized a rigid support angle. Fastener configurations for BUBF18 deck profiles are given in Figure 4.6 while Figure 4.7 illustrates fastener configurations for the BOSW18 deck profiles.

4.2.3 8' Wide Panel - Missing Fasteners. Table 4.3 shows the results of a test on an unloaded Bowman Super 8 deck profile (BOS816) with a standard end fastener configuration and several conditions of missing side lap fasteners. Figure 4.13 illustrates the 8 foot wide deck panel and shows that both end fasteners and side lap fasteners are in the standard configuration for the initial portion of the test. The test then proceeded with stiffness values determined after the removal of one, two and all three of the side lap fastener rows. Three side lap fasteners were removed for each row eliminated as indicated in Figure 4.13. One final test was conducted on an 8' wide panel of BOS816 type deck with standard end fastener and standard side lap fastener configurations. This test was conducted with an 80 psf dead load present and was loaded laterally to failure. The deck panel shear strength is listed in Table 4.3.

Table 4.2 Test results for combinations of standard and fully fastened configurations.

Deck Type	End Fastener Configuration	Side Lap Fastener Configuration	Unloaded G'_{IU} (kips/inch)
BUBF18	Std.	Std.	39
BUBF18	Full	Std.	51
BUBF18	Std.	Full	53
BUBF18	Full	Full	75
BOSW18	Std.	Std.	31
BOSW18	Full	Std.	49
BOSW18	Std.	Full	35
BOSW18	Full	Full	60

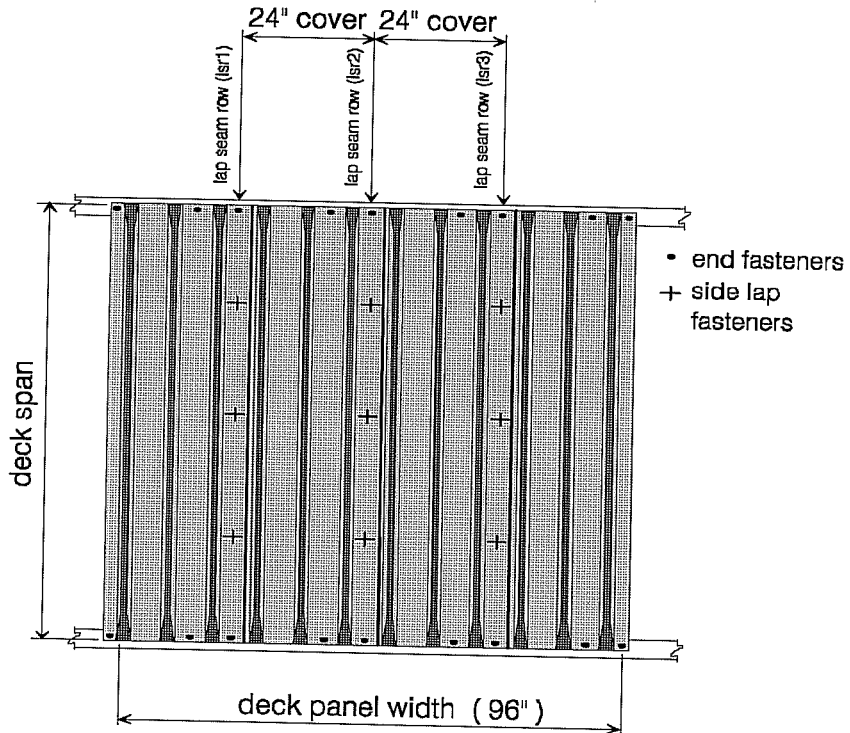

Figure 4.13 Eight-ft. wide panel with standard end and side lap fasteners.

Table 4.3 Test results for 8' wide panel with missing side lap fasteners.

Deck Type	End Fastener Configuration	Side Lap Fastener Configuration	Unloaded G'_{IU} (kips/in.)	Loaded S_{avg} (kips/in.)	Loaded $S_{avg}/\text{Fastener}$ (kips/in./fast.)
BOS816	Std.	Std.	43	0.075	0.0084
BOS816	Std.	Missing LSR 3	41		
BOS816	Std.	Missing LSR 1 & 3	29		
BOS816	Std.	Missing LSR 1,2 & 3	20		

An investigation of the effect of missing end fasteners was conducted using an 8 foot wide unloaded deck panel of Bowman Super 8 deck (BOS816). Initially the deck panel was tested with standard end fasteners and standard side lap fasteners as illustrated in Figure 4.8. An additional test was conducted with end fasteners located only at the lap seams. The side lap fasteners remained in the standard configuration for both tests. The results of these tests are presented in Table 4.4.

Once again, the tests described above all use a rigid support angle connection shown in Figure 3.7.

4.2.4 12' Wide Panel. All results presented to this point have been extracted from deck stiffness tests conducted on deck panels that were approximately 8 feet in width. Stiffness values for 12 foot wide deck panels with several different fastener configurations will be presented in this section.

Table 4.4 Test results for 8' wide panel with missing end fasteners.

Deck Type	End Fastener Configuration	Side Lap Fastener Configuration	Unloaded G'_{IU} (kips/inch)
BOS816	Std.	Std.	43
BOS816	At Lap Seams Only	Std.	33

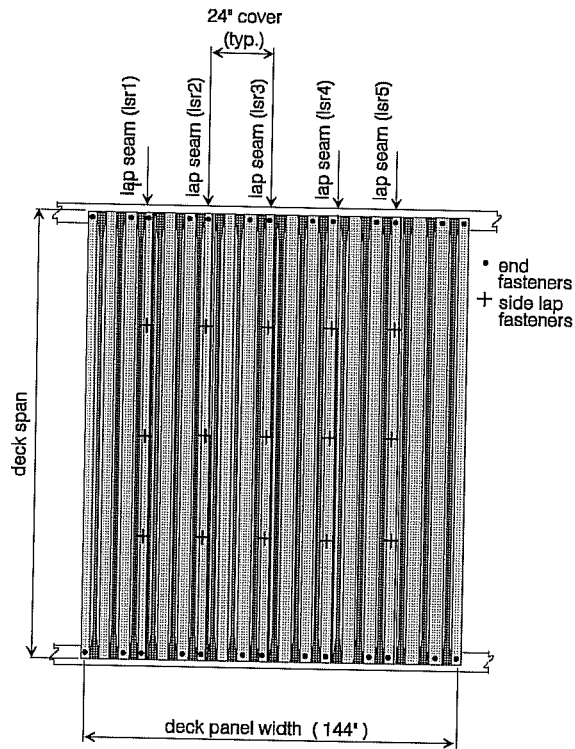

Figure 4.14 Twelve-ft. wide panel with standard end and side lap fasteners.

Figure 4.14 shows the Bowman Super 8 deck panel arrangement, with standard fastener configuration, which was used for this series of tests. The initial test was conducted with both end and side lap fasteners in the standard fastener configuration. Three additional tests were executed by eliminating two, four and five complete rows of side lap fasteners while, at the same time, end fasteners remained in the standard configuration. Results of these tests, all of which were conducted with no out-of-plane dead load, are presented in Table 4.5. One final test was conducted on a 12' wide panel of BOS816 type deck with standard end fastener and standard side lap fastener configurations. This test was conducted with an 80 psf dead load present and was loaded laterally to failure. The deck panel shear strength is listed in Table 4.5.

4.2.5 Support Angle Configurations. Four LSM deck profile types were tested using the welded angle eccentric connection shown in Figure 3.7 of this report. Additionally, one of the LSM profiles was also tested using the strap angle eccentric connection shown in Figure 3.9. All of these tests were conducted on 8' wide panels in the loaded condition and used the appropriate fastener configurations given in Figures 4.9 and 4.10. Shear stiffness values were computed using the $.4 P_{ult}$ method and are presented in Table 4.6.

These tests are to be used to obtain an indication of the effect of the deck support method on the shear stiffness of the deck system. With this in mind, shear stiffness values from tests using a rigid support system are also listed in Table 4.6.

Table 4.5 Test results for 12' wide panel with missing side lap fasteners.

Deck Type	End Fastener Configuration	Side Lap Fastener Configuration	Unloaded G'_{IU} (k/in)	Loaded S_{avg} (k/in)	Loaded $S_{avg}/Fast.$ (k/in/fast)
BOS816	Std.	Std.	46	0.080	0.0062
BOS816	Std.	Missing LSR 1 & 5	38		
BOS816	Std.	Missing LSR 1,2,4 & 5	29		
BOS816	Std.	Missing LSR 1,2,3,4 & 5	25		

Table 4.6 Comparison of rigid support tests with eccentric support tests - 8' wide panels.

Deck Type	Rigid Support $G'_{.4Pult}$ (kips/inch)	Welded Angle Eccentric Support $G'_{.4Pult}$ (kips/inch)	Strap Angle Eccentric Support $G'_{.4Pult}$ (kips/inch)	Welded Angle Eccentric Support S_{avg} at Ultimate (kips/inch)	Welded Angle Eccentric Support $S_{avg}/Fastener$ (kips/in./fast.)
LSM1516	59	6 ^a		0.069	0.0058
LSM1524	41	7		0.054	0.0068
LSM2216	26	12	10	0.075 ^b	0.0063
LSM2224	21	11		0.049	0.0061

a - average of two tests

b - value is 0.075 for both welded angle and strap angle tests

One additional test was conducted using the welded angle eccentric connection. This test utilized a flat soffit deck profile (LSM2224) that had an overall panel width of 14'. This test was conducted loaded in the fully fastened configuration and was tested to failure. A welded angle eccentric connection was used for this test in order to determine the effect of panel width on the shear stiffness of a deck/support angle system. Results from this 14' wide test are presented in Table 4.7. For comparison, 8' wide panel test results are also shown in Table 4.7 for both the rigid support connection and the welded angle eccentric support connection. It should be noted that $G'_{.4P_{ult}}$ listed for the 14' wide panel is actually G' computed at a lateral load of approximately 2.0 kips. This value was chosen to reflect a lateral load at approximately the same relative position (near the end of the elastic region of the load-deflection curve) as the $.4P_{ult}$ values for the 8' wide panel tests.

4.2.6 Powder-Actuated Fasteners. One pilot test was conducted using Hilti powder-actuated fasteners, for the end fasteners, in place of the TEKS screws. These fasteners were Hilti ENP2K-20 L 15 fasteners and were installed using a Hilti Model DX 750 Powder Actuated System with a "green" power level .27 caliber cartridge. TEKS screws were used at the side lap connections.

A BUBF14 deck profile was used for this test and was fully fastened as illustrated in Figure 4.6. The test was conducted in the loaded configuration with an 80 psf dead load in place and used a rigid deck support. Values for initial cycle G' , G' at $.4 P_{ult}$ and diaphragm shear strength are listed in Table 4.8. Values are also given, for the same deck panel profile and configuration, with TEKS screws at the end fasteners for comparison.

Table 4.7 Comparison of 8' wide and 14' wide panels - rigid and eccentric supports.

LSM2224 Fully Fastened	G'_{IU}	G'_{IL}	$G'_{.4P_{ult}}$	$.4P_{ult}$	S_{avg}	$S_{avg}/Fastener$
	(kips/in.)	(kips/in.)	(kips/in.)	(kips)	(kips/in.)	(kips/in./fast.)
8' Wide Panel Rigid Connection	13	20	21	1.14	0.050	0.0063
8' Wide Panel Welded Angle Connection	9	10	11	1.13	0.049	0.0061
14' Wide Panel Welded Angle Connection	14	22	20 ^a	3.76	0.095	0.0068

a - This stiffness was measured at a lateral load of approximately 2 kips.

Table 4.8 Comparison of end fastener types - 8' wide panel.

Deck Type	End Fastener Type	Initial Cycle Loaded Stiffness G'_{IL} (kips/inch)	$.4P_{ult}$ Method Loaded Stiffness $G'_{.4P_{ult}}$ (kips/inch)	S_{avg} at Ultimate (kips/inch)
BUBF14	TEKS	98	88	0.156
BUBF14	HILTI	91	86	0.157

4.3 Modes of Failure

It was illustrated in Chapter 1 that the shear strength of the deck panels in the test program would probably be controlled by either the failure of an end fastener, deck bearing deformation at an end fastener in a direction parallel to the deck span or failure of the deck support angle. This third failure possibility will only be a concern for those tests conducted using a support method other than the rigid support configuration. The following sections report the tendencies which were observed for the tests that were continued to a limit state.

4.3.1 Failure of an End Fastener. Tests controlled by the fracture of an end fastener included the three open profile deck types fabricated of Grade E material (BUBF18, BUBF16 and BUBF14) and the heavier gage flat soffit deck profile types (LSM) fabricated of Grade C material (LSM1516, LSM1524, LSM1716 and LSM1724).

The initial fastener fracture occurring in these tests was located at a corner of the overall deck panel with the exception of the BUBF14 deck profile which realized a fastener fracture at the center of the panel end just prior to the fracture of a corner fastener. These fastener failures were accompanied by a noticeable bearing deformation at the corner end fasteners, shown in Figure 4.15, but was less pronounced for the two heavier gage Grade E material decks (BUBF16 and BUBF14).

Movement of individual deck sheets relative to their adjacent deck sheets was also evidenced by some slight deck bearing deformation and fastener tipping at the side lap seams. This deformation was minimal and no side lap fastener fractures were encountered.

4.3.2 Substantial Deck Bearing Deformation. Several of the deck profiles tested were ultimately controlled by tear-out of the deck material at the end fasteners without a fracture of the fastener. This condition is shown in Figure 4.16 and was found to be the controlling factor for the Grade C open profile deck types (BOS816, BOSW18 and BO8.5P) and also for the lightest gage LSM

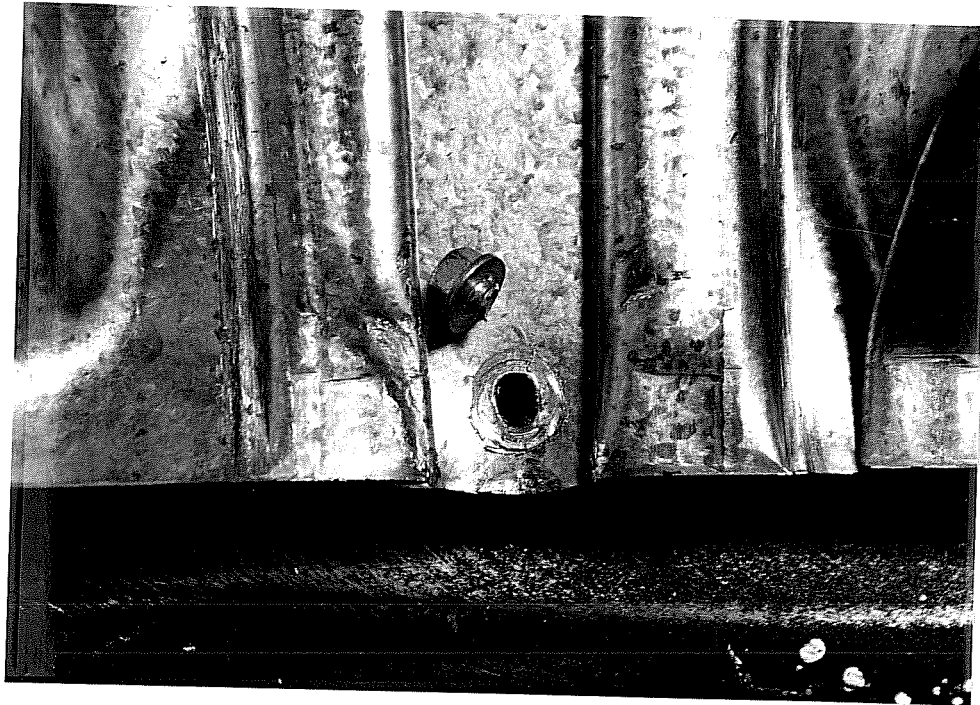

Figure 4.15 Fastener fracture accompanied by bearing deformation.

deck profile (LSM2216 and LSM2224). It should be noted that the deck bearing encountered was all parallel to the deck span and that no deck bearing perpendicular to the deck span was found in any of the deck tests.

Once again, the deck tear-outs noted above were all located at the corners of the overall deck panel with smaller amounts of deformation occurring at the interior end fasteners.

The same type of individual deck movement was exhibited in these tests as was the case for the tests involving fastener failures.

4.3.3 Deck Support Angle Failures. Several pilot tests were conducted using either the welded angle eccentric connection or the strap angle eccentric connection. Failure results for these tests were similar to the tests discussed above, however, it was found that the support angle experienced substantial warping prior to any fastener fracture or deck tear-out. This warping is illustrated in Figures 4.17 and 4.18 for the deck bearing angles at their respective tension and compression deck panel corners. The warping of the support angle became so severe in some tests that welds connecting the support angle to the hold down clips failed prior to any fastener fractures.

4.3.4 Powder-Actuated Fastener Failures. The pilot test conducted using powder-actuated fasteners at the deck panel ends, while producing an ultimate load very nearly the same as the test of its TEKS screw counterpart, displayed a considerably different failure mode. Pins at the ends of the deck panel were pulled out of the support angle and were not fractured.

The initial pins to be pulled out of the support angle during the test were the deck end pins at the center of the overall deck panel rather than the corner pins. Pins at the corners of the overall deck panel were tipped substantially but there was only minimal deck bearing deformation at any of the end pins. It should be noted that the test of the same deck profile (BUBF14), using TEKS screws at the deck ends, also resulted in the fracture of one of the deck end screws located at the center of the overall deck panel.

This pilot test also differed from the TEKS screw tests in that all TEKS fasteners in the middle row of side lap fasteners were fractured during the test and there was a significant amount of movement of adjacent panels at this lap seam. Bearing deformation and fastener tipping at the remaining lap seams was only slight and similar to the test performed with TEKS screws at the deck panel ends.

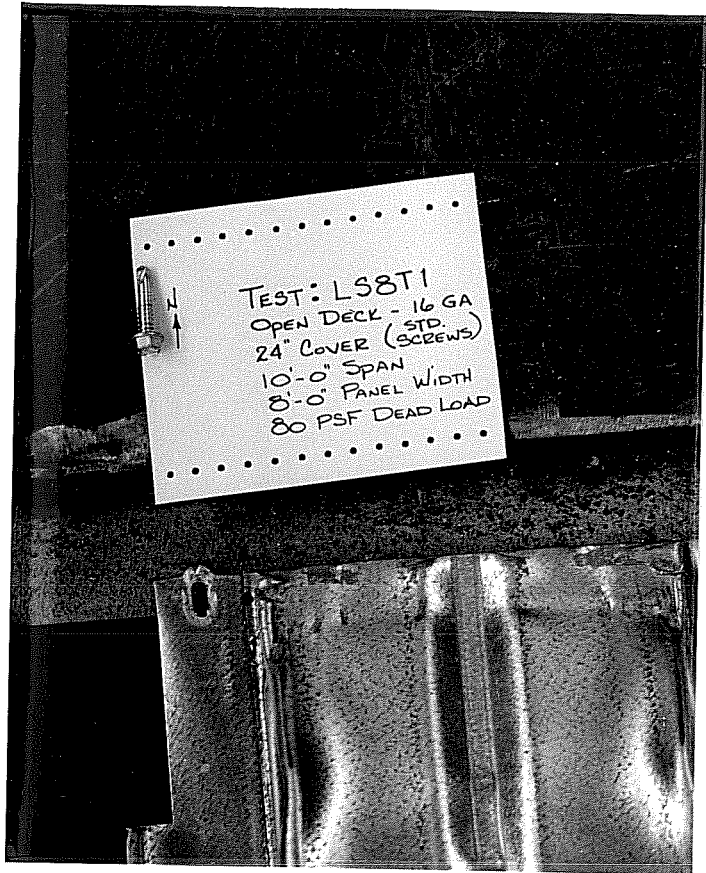

Figure 4.16 Tear-out of deck material at fastener location.



Figure 4.17 Support angle warping at tension corner.

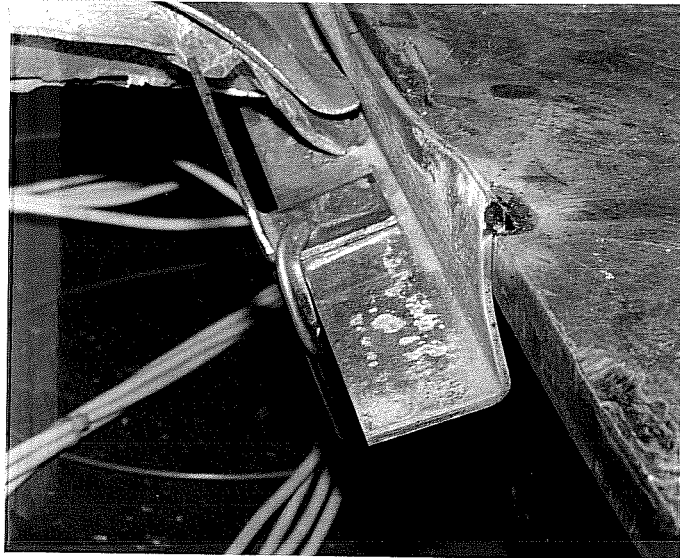

Figure 4.18 Support angle warping at compression corner.

CHAPTER 5

ANALYSIS & COMPARISON OF RESULTS

5.1 Overview

This chapter contains an analysis of the test results presented in Chapter 4 and will focus on the primary objectives of the study, namely:

- 1.) the effect of fastener spacings on the shear stiffness of a diaphragm composed of Permanent Steel Bridge Deck Forms.
- 2.) the determination of an appropriate value of design shear stiffness for each deck profile type tested, based on experimental test results.
- 3.) the determination of an appropriate value of design shear strength for each deck profile type tested, based on experimental test results.
- 4.) an examination of the effects of non-rigid deck support configurations on shear stiffness and shear strength and the development of the stiffness associated with this support condition.
- 5.) the effect of overall panel width on shear stiffness and shear strength.
- 6.) the change in shear stiffness and shear strength resulting from the use of powder-actuated pins in place of TEKS screws at the deck end fasteners.
- 7.) development of procedures to allow an approximate determination of shear stiffness and shear strength capacities of Permanent Steel Bridge Deck Forms without experimental testing.

5.2 Effect of Fastener Spacings on Shear Stiffness

Numerous tests were conducted in this study in an attempt to determine the effect that the end fastener spacings and side lap fastener spacings have on the shear stiffness of diaphragms consisting of Permanent Steel Bridge Deck Forms.

As was presented earlier, standard fastener configurations were end and side lap fastener spacings recommended by the deck manufacturers for flexural considerations of their particular decks. Fully fastened configurations were arbitrarily chosen by the researchers as rational spacings which could be easily used in the field and at the same time maximize the stiffness characteristics of the deck panels. Open profile type decks were considered to have fully fastened ends when end fasteners were located in every rib trough. Fully fastened lap seams were defined as side lap fasteners spaced at 15" to 18" for the open profile deck types. For the LSM decks, the standard end and side lap fastener configurations were considered adequate and were, therefore, also defined as fully fastened. This

standard/fully fastened configuration consists of end fasteners at every rib trough and 8 side lap fasteners along the span at every side lap location. The standard and fully fastened configurations for all deck types were presented in Chapter 4, Figures 4.6 through 4.10.

Table 5.1 contains a comparison of results from the tests of two open profile deck types which were tested unloaded using various combinations of end and side lap fastener configurations. These results indicate decreases in shear stiffness of 29% and 42% when end fasteners are located in every other rib trough instead of every trough. Increasing the side lap fastener spacing from 16" to 48" results in a decrease in stiffness of 32% for the BUBF18 deck. For the BOSW18 deck, increasing the side lap fastener spacing from 16" to 32" results in an 18% decrease in stiffness. These test results indicate that both end fastener spacings and side lap fastener spacings have considerable effect on the shear stiffness of a particular deck panel.

Table 5.1 Effect of fastener spacing on shear stiffness.

Deck Type	End Fastener Configuration	Side Lap Fastener Configuration	Unloaded Shear Stiffness G'_{IU} (kips/inch)	Decrease in Stiffness
BUBF18	Full	Full	75	Basis
	Std.	Full	53	29%
	Full	Std.	51	32%
BOSW18	Full	Full	60	Basis
	Std.	Full	35	42%
	Full	Std.	49	18%

A comparison of deck panels consisting of standard end and side lap fasteners with deck panels having fully fastened ends and side laps can be found in Table 5.2. All of the open profile decks were included in these tests which were conducted in the unloaded configuration. Results of these deck tests show considerable decreases in shear stiffness when panels with standard fastener configurations are used to replace panels with fully fastened configurations. It should be noted that all deck types whose standard fastener configurations consist of end fasteners in every other rib trough and side lap fasteners approximately 48" o.c. exhibit a stiffness decrease of 40% to 50% from their fully fastened configurations. The BOS816 deck profile shows only a 27% decrease in stiffness comparing the standard fastener configuration with the fully fastened configuration. This smaller reduction in stiffness is due to the fact that the standard fastener configuration for this deck type consists of side lap fasteners spaced at 30" o.c. and has end fasteners omitted at every third fastener instead of every other fastener (see Figure 4.8). The comparisons in Table 5.2 illustrate the significant decreases in shear stiffness that can be expected when both end fastener spacings and side lap fastener spacings are increased.

Table 5.2 Shear stiffness comparison of standard fastener configurations with fully fastened configurations.

Deck Type	Standard Fastener Configuration G'_{IU} (kips/inch)	Fully Fastened Configuration G'_{IU} (kips/inch)	Decrease in Shear Stiffness
BUBF18	39	75	48%
BUBF16	45	83	46%
BUBF14	58	99	41%
BOS816	43	59	27%
BOSW18	31	60	48%
BO8.5P	49	93	47%

The results of three additional tests presented in Chapter 4 also indicate the effect of fastener spacings on shear stiffness. Table 4.4 presents the results of a test in which all of the end fasteners were removed from the deck panel except for the end fasteners at the lap seams. Side lap fasteners for this test were in the standard fastener configuration. The shear stiffness value of 33 kips/inch from this test represented a 23% reduction from the test with standard end fasteners. The other two tests, whose results are presented in Tables 4.3 and 4.5, were conducted unloaded and consisted of panels with standard end fasteners in combination with various conditions of missing rows of standard side lap fasteners. The first of these two tests, Table 4.3, was conducted on an 8' wide deck panel and demonstrated a shear stiffness reduction of 53% upon removal of all side lap fasteners. The second test was performed on a 12' wide deck panel and resulted in a similar stiffness reduction of 46% when all side lap fasteners were removed. The results of this second test can be found in Table 4.5.

Unquestionably, the shear stiffness of a particular deck diaphragm is dependent on the number and spacing of both the end fasteners and side lap fasteners. A substantial decrease in shear stiffness is realized when either end fasteners or side lap fasteners are omitted. Shear stiffness of panels with standard fastener configurations are only slightly more than half the stiffness of fully fastened panels.

5.3 Experimental Shear Stiffness Values

The shear stiffness of a deck diaphragm is of great importance when the intended use is as a lateral bracing element. Results presented in previous sections indicate the importance of closely spaced end and side lap fasteners to the shear stiffness of a diaphragm. For these reasons, experimental values will only be considered for fully fastened deck panels.

All deck profile types were tested both unloaded and loaded using a fully fastened configuration. Stiffness values were calculated using three separate methods, specifically, unloaded initial cycle stiffness (G'_{IU}), loaded initial cycle stiffness (G'_{IL}) and loaded $.4P_{ult}$ stiffness ($G'_{.4P_{ult}}$). Examples of these stiffness calculations were presented in Chapter 4. Comparison of these three stiffness values will be made in the following sections to determine reasonable design stiffness values for each deck profile type based on the experimental data.

Stiffness values for the fully fastened tests using the open profile deck types are examined in Section 5.3.1. Section 5.3.2 compares the measured stiffnesses for the fully fastened flat soffit (LSM) decks.

5.3.1 Open Profile Stiffness Values. Comparison of initial cycle loaded stiffness to initial cycle unloaded stiffness, from Table 5.3, indicates an increase in shear stiffness, for most of the open profile decks, following the addition of the 80 psf dead load. These stiffness increases, which ranged from 0% to 17%, can possibly be attributed to the sliding friction between the concrete dead load blocks on the top surface of the deck forms. This sliding friction will create a resistance to movement of the deck with respect to the concrete blocks and will somewhat prevent the deck profile from warping during the application of the shear strain. This will result in a slight increase in the measured shear stiffness. The added dead load will also increase the contact friction between the individual deck sheets at the lap seams and may increase the contact friction between the deck and the support angle at the deck ends. These increases in contact friction will also increase the measured shear stiffness.

A comparison of loaded stiffness values computed using the initial cycle method and the loaded stiffness values obtained using the $.4P_{ult}$ method indicate that the $.4P_{ult}$ method results in reduced stiffness values for all the open profile decks tested. The data also show a reasonably good comparison between the unloaded stiffness values and the $.4P_{ult}$ loaded stiffness values.

Table 5.3 Open profile type deck stiffness comparisons - fully fastened configuration.

Deck Type	Span (feet)	Unloaded Initial Cycle Stiffness G'_{IU} (kips/inch)	Loaded Initial Cycle Stiffness G'_{IL} (kips/inch)	Loaded $.4P_{ult}$ Stiffness $G'_{.4P_{ult}}$ (kips/inch)	G'_{IL} / G'_{IU}	$G'_{.4P_{ult}} / G'_{IU}$	$G'_{.4P_{ult}} / G'_{IL}$
BUBF18	8'-0"	75	77	72	1.03	.96	.94
BUBF16	7'-9"	83	94	82	1.13	.99	.87
BUBF14	8'-6"	99	98	88	.99	.89	.90
BOS816	10'-0"	59	59	54	1.00	.92	.92
BOSW18	8'-0"	60	70	66	1.17	1.10	.94
BO8.5P	7'-8"	93	95	94	1.02	1.01	.99

A comparison of loaded stiffness values computed using the $.4P_{ult}$ method with the unloaded and loaded initial cycle stiffnesses indicates that the $.4P_{ult}$ method produces conservative results for nearly all deck profiles. The only exception being the BOSW18 deck which showed a lower stiffness for the unloaded test.

These comparisons indicate that $G'_{.4P_{ult}}$ values should be used for design. They provide a reasonable lower bound to the initial small displacement stiffness measured in both the loaded and unloaded tests.

5.3.2 Flat Soffit (LSM) Profile Stiffness Values. Comparison of first cycle loaded stiffness to first cycle unloaded stiffness for the LSM deck types are given in Table 5.4. Once again, shear stiffness increases with the addition of the 80 psf dead load for all deck profiles. These stiffness increases ranged from 3% to 14% except for an increase of 29% for the LSM1724 profile and 54% for the LSM2224 profile. Dead load block friction, while possibly the source of the minor increases, is probably not solely responsible for the larger increases, particularly in the LSM2224 deck profile test. Because of the large increase in stiffness due to the addition of dead load, a second separate test was performed on an LSM2224 deck. This second test produced the same unloaded and loaded stiffness results as the first test. It appears that the stiffness of the lighter LSM decks placed in a 24" coverage will increase noticeably with the addition of dead load.

A comparison of loaded stiffness values computed using the initial cycle method and loaded stiffness values obtained using the $.4P_{ult}$ method indicate that the $.4P_{ult}$ method results in lower stiffness values for all of the flat soffit profile decks tested except for the LSM2216 and LSM2224 deck profiles. Results for these two profiles produced very nearly the same values for initial cycle and $.4P_{ult}$ methods. This was due to the fact that, for these two profiles, the loads at $.4P_{ult}$ were very close to the loads at which the initial cycle values were calculated resulting in essentially the same stiffness values.

Table 5.4 Flat soffit (LSM) type deck stiffness comparisons - fully fastened configuration.

Deck Type	Span (feet)	Unloaded Initial Cycle Stiffness G'_{IU} (kips/inch)	Loaded Initial Cycle Stiffness G'_{IL} (kips/inch)	Loaded $.4P_{ult}$ Stiffness $G'_{.4P_{ult}}$ (kips/inch)	G'_{IL} / G'_{IU}	$G'_{.4P_{ult}} / G'_{IU}$	$G'_{.4P_{ult}} / G'_{IL}$
LSM1516	12'-10"	63	65	59	1.03	.94	.91
LSM1524	12'-10"	38	42	41	1.11	1.08	.98
LSM1716	12'-10"	50	55	42	1.10	.84	.76
LSM1724	12'-10"	31	40	37	1.29	1.19	.93
LSM2216	8'-11½"	21	24	26	1.14	1.24	1.08
LSM2224	8'-11½"	13	20	21	1.54	1.62	1.05

A comparison of unloaded and loaded initial cycle shear stiffness to loaded $.4P_{ult}$ shear stiffness, while showing some scatter, indicates that the $.4P_{ult}$ stiffness values produce fairly consistent results for the majority of the decks tested. The $.4P_{ult}$ values listed in Table 5.4 should be used for design. Additional consideration should be given to light gage LSM decks used in the 24" coverage configuration with no applied dead load.

5.3.3 Recommended Design Shear Stiffness. Table 5.5 presents a summary of the shear stiffnesses measured for the deck profile types tested when used in a fully fastened configuration. Values listed represent $G'_{.4P_{ult}}$ values for both the open profile deck types and the LSM flat soffit profile types. Values presented in the table are valid only for the spans and gages listed.

It should be noted that the stiffness values listed in Table 5.5 are for fully fastened deck panels. Experimental shear stiffness values for the open deck profiles using alternate fastener configurations can be obtained from the results contained in Chapter 4 of this report. All of the tests with less than full fasteners were done without additional dead load. Consequently, only initial cycle unloaded shear stiffness values (G'_{IU}) are presented in Chapter 4 for the tests using alternate fastener configurations. Use of these values to predict the shear stiffness of loaded open profile deck panels should be done cautiously since results for the fully fastened decks (Table 5.3) show that G'_{IU} values are generally less conservative than $G'_{.4P_{ult}}$ values.

Flat soffit type (LSM) deck profiles were only tested using fully fastened configurations. Alternate fastener configurations are not recommended for the LSM decks.

Table 5.5 Experimental shear stiffness and shear strength values.

Deck Type	Span (feet)	Gage	Shear Stiffness G' (kips/inch)	Shear Strength S_{avg} (kips/inch)	Strength/Fastener $S_{avg}/\text{Fastener}$ (kips/inch/fastener)
BUBF18	8'-0"	18	72	0.142	0.0084
BUBF16	7'-9"	16	82	0.172	0.0101
BUBF14	8'-6"	14	88	0.156	0.0092
BOS816	10'-0"	16	54	0.103	0.0079
BOSW18	8'-0"	18	66	0.109	0.0084
BO8.5P	7'-8"	16	94	0.133	0.0102
LSM1516	12'-10"	15	59	0.095	0.0079
LSM1524	12'-10"	15	41	0.076	0.0095
LSM1716	12'-10"	17	42	0.108	0.0090
LSM1724	12'-10"	17	37	0.069	0.0086
LSM2216	8'-11½"	22	26	0.074	0.0062
LSM2224	8'-11½"	22	21	0.050	0.0063

5.4 Experimental Shear Strength Values

Table 5.5 also contains the values of shear strength for all of the decks tested. These diaphragm shear strengths are the average shear along the fastened panel edge at failure and are designated S_{avg} . Shear strength per fastener is also listed in Table 5.5. Shear strengths were measured only for loaded deck panels in the fully fastened configuration.

Shear strength per fastener values fall within a range of 0.008 to 0.01 kips/inch/fastener for all decks tested except for the 22 gage LSM decks which have a strength of approximately 0.006 kips/inch/fastener. These results once again point out the fact that fastener failure will likely control the shear strength of the heavier deck panels while deck bearing tear out at a fastener will likely control for the lighter decks.

5.5 Non-Rigid Support Configuration Considerations

Five pilot tests were conducted using the "non-rigid" support configurations described in Chapter 3. Four of these tests used the welded angle support and one test used the strap angle support. These pilot tests were designed to provide a preliminary determination of the effect these support configurations might have on the shear stiffness and shear strength of a deck/support angle system.

Stiffness comparisons of these eccentric angle support systems with the rigid support configuration are presented in Table 4.6. Welded angle support conditions reduced the deck system stiffness by more than 80% for the heavier (15 gage) decks and by nearly 50% for the lighter (22 gage) decks. Use of the strap angle connection further reduced the system stiffness of the 22 gage deck system.

It appears likely, based on these pilot tests, that shear stiffness of the deck panel/support angle systems is dominated by the flexibility of the deck support angle. This flexibility is dependent on the eccentricity of the connection and also on the thickness of the support angle. The method of deck support is of utmost importance in the determination of the shear stiffness of a deck panel/support angle system.

Shear strength results are presented in Table 4.1 for the rigid support condition and in Table 4.6 for the non-rigid support conditions. Comparison of these strengths show a reduction in strength of approximately 25% for the 15 gage decks when a non-rigid support is used. The 22 gage decks show the same shear strength for both the rigid and non-rigid configurations. The reduction in strength for the 15 gage decks appears to be contradictory to the behavior expected with a more flexible support. It was expected that a softer support condition would enable the deck system to redistribute the end fastener forces and produce an increase in the shear strength of the deck panel.

The reason for this apparent contradictory behavior is probably due to the extreme rotation of the support angle at ultimate load (refer to Figures 4.17 and 4.18). The rotation of the support angle produces a prying stress on the end fasteners that acts in conjunction with the shear stress present. This combination of stresses acting on the end fasteners may cause a fracture of an end screw at a lower applied lateral load than the load required to fracture an end fastener in the rigid support condition which does not have this prying stress present. The 22 gage decks do not experience this

phenomena due to the fact that tear-out of the deck material, at an end fastener, occurs before a large enough load is encountered to fracture an end fastener.

5.5.1 Estimation of Support Connection Stiffness. Development of the shear stiffness of the support angle was expected to be similar to the development of the stiffness of a system of springs connected in series where the inverse of the total system stiffness is defined as the sum of the inverse of the individual spring stiffnesses.

$$1/K_t = 1/K_1 + 1/K_2 + 1/K_3 + \dots$$

Using this approach, the stiffness of the support angle connection G'_c could be derived from the measured deck/angle support system stiffness G'_s and the measured deck stiffness G'_d as follows:

$$\begin{aligned} 1/G'_s &= 1/G'_d + 1/G'_c \\ 1/G'_c &= 1/G'_s - 1/G'_d \\ 1/G'_c &= (G'_d - G'_s) / (G'_s)(G'_d) \\ \text{so: } G'_c &= (G'_s)(G'_d) / (G'_d - G'_s) \end{aligned}$$

Calculated connection stiffnesses (G'_c) are presented in Table 5.6. The measured system stiffness values (G'_s) for the decks tested using the support angles and their corresponding measured deck stiffness values (G'_d) obtained using a rigid support connection are also shown. All of the deck tests included in this comparison were conducted on 8' wide panels.

Table 5.6 Development of support connection stiffness.

Deck Type	Span (feet)	Deck Stiffness G'_d (kips/inch)	System Stiffness G'_s (kips/inch)	Connection Stiffness G'_c (kips/inch)
WELDED ANGLE ECCENTRIC SUPPORT				
LSM1516	12'-10"	59	6	7
LSM1524	12'-10"	41	7	8
LSM2216	8'-11½"	26	12	22
LSM2224	8'-11½"	21	11	23
STRAP ANGLE ECCENTRIC SUPPORT				
LSM2216	8'-11½"	26	10	16

Comparison of these connection stiffnesses lead to the following observations:

- Connection stiffness appears to be dependent on the deck span.
- The strap angle connection appears to have less stiffness than the welded angle connection.

It was not expected that the span of the deck panels would effect the stiffness of the deck support angle. The results indicating this span dependence may be associated with the test setup in which the deck support angle is terminated about 1' beyond the deck panel edge (Figure 3.8). This free end of the deck support angle is connected to a hold down clip, however, the clip will not prevent rotation of the support angle. As the span is decreased, with the panel width remaining the same, the tension force which is acting across the panel diagonal has a larger component parallel to the test frame beam and a smaller component perpendicular to the beam. This action produces a smaller tension force on the angle for a given applied load and appears to increase the connection stiffness. This span dependence may not be as pronounced in an actual deck application due to the fact that the hold down clip will have deck support angles attached on both sides which will make the deck support angles behave like a continuous angle. This should increase the stiffness of the deck/support angle system.

Further investigation of these preliminary observations is beyond the scope of this study and will be addressed by the research mentioned earlier examining the stiffness capacities of various common deck support angle configurations.

5.6 Effect of Overall Panel Width

Several tests were performed to determine whether the overall width of a deck panel had any influence on the shear stiffness and shear strength of the deck panel or on the shear stiffness and shear strength of a deck/support angle system.

5.6.1 Deck Panel with Rigid Connection. Tests were conducted on an open profile deck (BOS816) using both a 12' wide overall panel and an 8' wide overall panel. These tests were conducted unloaded with standard end fasteners and standard side lap fasteners using a rigid deck support configuration. A shear stiffness value of 46 kips/inch (Table 4.5) was measured for the 12' wide panel while the 8' wide panel test exhibited a shear stiffness of 43 kips/inch (Table 4.3). Comparison of these stiffness values indicates that the deck shear stiffness increased only 7% as the overall panel width was increased.

Twelve-ft. wide and 8' wide open decks (BOS816) were also tested with an 80 psf dead load present. These tests were conducted with standard end fasteners and standard side lap fasteners using a rigid deck support configuration and were loaded laterally to failure. A shear strength value of 0.080 kips/inch (Table 4.5) was measured for the 12' wide panel while the 8' wide panel test resulted in a shear strength of 0.075 kips/inch (Table 4.3). Comparison of these strength values indicates that the deck shear strength increased approximately 7% as the panel width was increased.

These results corroborate the premise that the shear stiffness and strength of a deck panel are only slightly increased as the deck panel's overall width is increased.⁴ Based on the increases of about

7% for the wider test panels, results from the test program using 8' wide panels should provide reasonable estimates of shear strength and shear stiffness for diaphragms consisting of wider or continuous deck panels.

5.6.2 Deck Panel with Welded Eccentric Angle Connection. A test was conducted utilizing a flat soffit deck profile (LSM2224) that had an overall panel width of 14'. This test was conducted loaded in the fully fastened configuration and was tested to failure. A welded angle eccentric support was used for this test in order to determine the effect of panel width on the shear stiffness of a deck/support angle system. Results from this 14' wide test are presented in Table 5.7. For comparison, 8' wide panel test results are also shown in Table 5.7 for both the rigid support connection and the welded angle eccentric support connection.

Comparison of the results given in Table 5.7 indicate that the shear stiffness of the deck/support angle system increases as the panel width increases. In fact the stiffness for this LSM2224 system increases to and is limited by the shear stiffness of the deck panel itself. This is evidenced by the fact that the 14' wide system stiffness is approximately equal to the 8' wide rigid connection deck stiffness. This increase in stiffness with increase in panel width is similar to the increases noted in Section 5.5.1 which were assumed to be due to a change in the line of action of the tension diagonal in the panel.

It can also be seen from the results presented in Table 5.7 that the shear strength S_{avg} increases substantially with panel width.

Table 5.7 Comparison of 8' wide and 14' wide panels - rigid & eccentric supports.

LSM2224 Fully Fastened	G'_{IU}	G'_{IL}	$G'_{.4Pult}$	$.4P_{ult}$	S_{avg}	$S_{avg}/Fastener$
	(k/in.)	(k/in.)	(k/in.)	(kips)	(k/in.)	(k/in./fast.)
8' Wide Panel Rigid Connection	13	20	21	1.14	0.050	0.0063
8' Wide Panel Welded Angle Connection	9	10	11	1.13	0.049	0.0061
14' Wide Panel Welded Angle Connection	14	22	20 ^a	3.76	0.095	0.0068

a - This stiffness was measured at a lateral load of approximately 2 kips.

Additional study of these support angle effects is required but is beyond the scope of this study.

5.7 Powder-Actuated Pins at End Fasteners

One pilot test was conducted using Hilti powder-actuated fasteners for the end fasteners in place of the TEKS screws. This test used a BUBF14 deck profile and was a loaded test using a fully fastened configuration. Table 4.8 compares the results of this test to a test of the same deck profile with TEKS screws at the end fasteners. These results show values for both $.4P_{ult}$ shear stiffness and ultimate shear strength to be almost identical for the two fastener types.

Although stiffness and strength values were the same, it should be noted that the modes of failure for the two types of end fasteners were not. Application of lateral load to failure resulted in the fracture of the end TEKS screws, however, the Hilti end fasteners pulled out of the deck support angle instead of fracturing.

5.8 Design Manual Stiffness and Strength

A design manual has been developed by the Steel Deck Institute (SDI) to provide a means of estimating the shear strength and shear stiffness of a particular deck diaphragm based on the physical properties of the deck sheets and their fastener layout. This design aid is the result of considerable testing on a variety of deck types commonly used in the building industry⁴ and enables the designer to evaluate the shear capacities of a particular deck without the expense of laboratory testing.

The purpose of this section is to determine if these design manual formulations can be used to provide an adequate estimation of stiffness and strength for Permanent Steel Bridge Deck Forms. This will be accomplished by comparing capacities measured in this study's test program to values computed using the SDI Manual equations.

Stiffness comparisons will be presented in Section 5.8.1 and strength comparisons in Section 5.8.2.

5.8.1 SDI Design Stiffness vs. Measured Stiffness. This section contains a comparison of several experimentally measured shear stiffness values to diaphragm stiffness values computed using diaphragm stiffness formulations from the Second Edition of the Steel Deck Institute Diaphragm Design Manual. The purpose of this comparison was to determine if the stiffnesses measured in this study were of the same magnitude as design formula shear stiffnesses which are based on previous test programs conducted for the Steel Deck Institute.

Diaphragm stiffness was computed using equation 3.3-3 from the SDI manual.

$$G' = \left(Et \right) / \left(2.6 (s/d) + \phi D_n + C \right) \quad (\text{Eq. 5.8-1})$$

Diaphragm geometries used with this stiffness equation and an example of its use are presented in Appendix A. The following assumptions were made in order to apply the SDI equations to the decks included in this study:

- 1.) Values for S_f and S_s were calculated using SDI manual equations 4.5.1-1 and 4.5.1-2. These equations are presented in the SDI manual for No. 12 and No. 14 Buildex TEKS screws. It was assumed that the 1/4" diameter Buildex TEKS screws used in this study would have little or no effect on the screw flexibilities, S_f and S_s .⁴
- 2.) The warping constant D-values were developed using the equations presented in Appendix IV of the SDI manual and neglected radius corners and formed deck stiffeners in the deck profiles. These straight line approximations are shown in Figure 5.1. Deck profile dimensions used in the equations were taken from dimensional drawings furnished by the deck manufacturers and are listed in Table A.1, Appendix A, of this report.

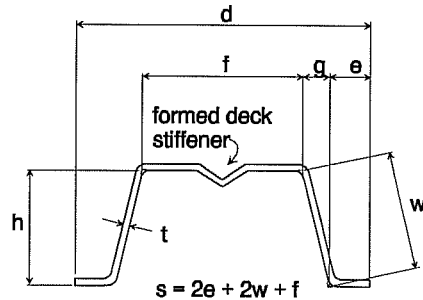

Figure 5.1 Deck profile dimensions used in manual equations.

Warping constants, D_n , are developed in the SDI design manual assuming open ended corrugated deck elements.⁴ Deck profiles used in this study actually have a tapered closure at the deck ends which should add some resistance to warping at the corrugation ends. It was expected that the stiffnesses measured in this study would fall somewhere between an open ended type deck panel and a fully closed end type deck. In order to make this comparison, two SDI stiffness values are presented. A closed end stiffness was computed by removing the D_n term from Equation 5.8-1. Open end stiffness values were computed using the SDI manual D_n values noted above. Both of these stiffness values are presented in the stiffness comparison tables that follow.

The open profile type deck panels tested in this study have essentially the same basic profile and lap seam configuration as the deck types that were included in the SDI testing program leading to the development of the SDI Design Manual. For this reason, it is rational that the SDI equations can be applied to the open profile decks with only minor modifications. The modifications to the SDI equations and an example stiffness calculation are presented in Appendix A.

Application of the SDI equations to the LSM flat soffit deck types is not as straightforward. The LSM type decks have profiles and lap seam configurations that are considerably different from

the SDI decks. The two main differences found in the LSM decks are the covers which box either one or both of the open troughs and the multiple number of side lap fastener rows which occur in the LSM decks. These differences lead to confusion in the choice of individual deck sheet width and number of side lap fasteners per seam. Several combinations of sheet width and side lap fastener configurations were investigated to determine the geometric configurations that would result in calculated values close to the measured strengths and stiffnesses. The authors were unable to develop LSM geometric configurations which would produce SDI stiffness and strength values that were reasonably close to the measured capacities. As an alternative, empirical equations were derived based on the experimental results from the tests conducted on the LSM type decks. These equations are presented below. It should be noted that these empirical equations are based on a limited number of tests and are also not applicable to the open profile decks.

$$G' = 230,000 \left(\frac{t^2}{L} \right) \quad (\text{Eq. 5.8-2}) \quad \text{Applicable for LSM decks in 16-in. coverage layout.}$$

$$G' = 150,000 \left(\frac{t^2}{L} \right) \quad (\text{Eq. 5.8-3}) \quad \text{Applicable for LSM decks in 24-in. coverage layout}$$

Where: G' = shear stiffness (kips/inch)
 t = base metal thickness (inches)
 L = panel length (feet)

Open profile type deck shear stiffness values were considered for two types of fastener configuration. Deck panels with end fasteners and side lap fasteners in the standard fastener configuration are presented in Table 5.8 while fully fastened deck panels are presented in Table 5.9.

Comparison of computed SDI stiffnesses to results of tests conducted in the standard fastener configuration, Table 5.8, reveal that all measured stiffnesses fall between the open and closed SDI stiffness as expected with most measured values near the middle of the SDI stiffness range.

Fully fastened deck panel comparisons, given in Table 5.9, result in measured shear stiffnesses approximately equal to the open SDI stiffness values for all of the open profile deck types. This would indicate that the tapered ends of the deck sheets do not provide much, if any, additional stiffness when end fasteners are closely spaced. In other words, the open profile bridge deck types with tapered ends behave similarly to open ended SDI decks when bridge deck end fasteners are located in every trough and side lap fasteners are also closely spaced.

Fully fastened LSM decks are compared in Table 5.10. Experimentally measured stiffnesses are compared to stiffness values calculated using equations 5.8-2 and 5.8-3. LSM experimental stiffnesses are not compared to SDI stiffnesses for the reasons previously mentioned.

It appears that use of the SDI Design Manual's procedure, with the modifications noted in Appendix A, to estimate shear stiffness capacities for open profile Permanent Steel Bridge Form Decks

Table 5.8 Comparison of experimental and SDI shear stiffness values - open profile decks - standard fastener configuration.

Deck Type	Span (feet)	Gage	SDI Stiffness Closed G'_{closed} (kips/inch)	SDI Stiffness Open G'_{open} (kips/inch)	Experimental Unloaded Stiffness G'_{meas} (kips/inch)	$G'_{\text{meas}} / G'_{\text{open}}$
BUBF18	8'-0"	18	51	15	39	2.60
BUBF16	7'-9"	16	56	27	45	1.67
BUBF14	8'-6"	14	61	30	58	1.93
BOS816	10'-0"	16	63	14	43	3.07
BOSW18	8'-0"	18	67	12	31	2.58
BO8.5P	7'-8"	16	86	19	49	2.58

Table 5.9 Comparison of experimental and SDI shear stiffness values - open profile decks - fully fastened configuration.

Deck Type	Span (feet)	Gage	SDI Stiffness Closed G'_{closed} (kips/inch)	SDI Stiffness Open G'_{open} (kips/inch)	Experimental Loaded Stiffness G'_{meas} (kips/inch)	$G'_{\text{meas}} / G'_{\text{open}}$
BUBF18	8'-0"	18	92	69	72	1.04
BUBF16	7'-9"	16	103	94	82	.87
BUBF14	8'-6"	14	113	99	88	.89
BOS816	10'-0"	16	81	40	54	1.35
BOSW18	8'-0"	18	101	68	66	.97
BO8.5P	7'-8"	16	132	82	94	1.15

Table 5.10 Comparison of experimental and empirical shear stiffness values - LSM decks - fully fastened configuration.

Deck Type	Span (feet)	Gage	Empirical Stiffness G'_{emp} (kips/inch)	Experimental Loaded Stiffness G'_{meas} (kips/inch)	G'_{meas} / G'_{emp}
LSM1516	12'-10"	15	65	59	.91
LSM1524	12'-10"	15	42	41	.98
LSM1716	12'-10"	17	52	42	.81
LSM1724	12'-10"	17	34	37	1.09
LSM2216	8'-11½"	22	23	26	1.13
LSM2224	8'-11½"	22	15	21	1.4

will result in values of the same order of magnitude as those values that might be expected from laboratory testing. Test results indicate that use of the SDI stiffness Equation 5.8-1 should include the warping constant term, D_n . Inclusion of the warping constant will result in reasonable predicted stiffness values for fully fastened open profile deck panels. Including the warping constant in the stiffness calculations for open profile panels which are less than fully fastened will generally result in conservative predicted stiffnesses.

The SDI procedure is not easily used for the LSM profile deck types. Empirical equations (Eq. 5.8-2 and Eq. 5.8-3) were developed using the results of the flat soffit tests included in this study. These equations can be used to estimate the shear stiffness capacities of the LSM decks. The user should be aware that these empirical equations were based on a limited number of tests.

5.8.2 SDI Design Strength vs. Measured Strength. Measured diaphragm shear strengths were also compared to shear strengths computed using the shear strength equations presented in Chapter 2 of the Steel Deck Institute Diaphragm Design Manual's Second Edition. The design strength of a diaphragm is limited to the smaller value from equations 2.2-2, 2.2-4a or 2.2-5 shown in the SDI Manual.⁴ These equations are presented below.

$$\text{SDI Eq. 2.2-2} \quad S_{u1} = (2\alpha_1 + n_p\alpha_2 + n_e)Q_f/L \quad (\text{Eq. 5.8-4})$$

$$\text{SDI Eq. 2.2-4a} \quad S_{u2} = [2A(\lambda - 1) + B]Q_f/L \quad (\text{Eq. 5.8-5})$$

$$\text{SDI Eq. 2.2-5} \quad S_{u3} = [N^2B^2/(L^2N^2 + B^2)]^{0.5} Q_f \quad (\text{Eq. 5.8-6})$$

Development of these equations in the SDI Manual indicates that the shear strength predicted using Eq. 2.2-2 is primarily dependent upon the edge fasteners which include edge connectors, purlin connectors and end connectors. Eq. 2.2-4a predicts the shear capacity associated with the interior panel connectors which include purlin connectors, seam connectors and end connectors. Eq. 2.2-5 predicts the maximum possible resultant force that can exist on a corner fastener in a deck panel. It

should be noted that Eq. 2.2-5 had to be modified for use with Permanent Steel Bridge Deck Forms and is not used in the form shown above. These modifications and the resulting equation are presented in Appendix A. SDI Equation 2.2-5 shown above should not be used to calculate the shear strength of Permanent Steel Bridge Deck Forms. It is expected that because there are no purlin connectors nor any edge connectors along the deck span Equation 2.2-2 will underestimate the shear strength of the deck panels in the test program. Equation 2.2-4a and the modified version of Equation 2.2-5 are expected to predict reasonable shear strength values.

The shear strength equations and their associated diaphragm geometries are presented in Appendix A and are limited by the following assumptions:

- 1.) Values for Q_f and Q_s were calculated using SDI manual equations 4.5-1 and 4.5-2. It is noted in the SDI Manual that the structural fastener strength, Q_f , is the same for No. 12 and No. 14 Buildex TEKS screws. It will be assumed that the 1/4" diameter Buildex TEKS screws used in this study will develop approximately the same structural fastener strength as the No. 14 Buildex TEKS screw which has a diameter of .2477".⁴

The deck layouts and their corresponding geometries used in the computation of SDI shear strength values are the same ones used in the stiffness calculations which are presented in Appendix A. An example calculation of shear strength is also shown in Appendix A.

It was found that the SDI shear strength equations were appropriate for use with the open profile decks only. Empirical equations were once again developed, based on the test results, to provide an estimate of the shear strength capacities of LSM flat soffit deck types. These equations are:

$$S_{avg} = 0.000035 (L^3/t) \quad (\text{Eq. 5.8-7}) \quad \text{Applicable for LSM decks in 16" coverage layout}$$

$$S_{avg} = 0.0000235 (L^3/t) \quad (\text{Eq. 5.8-8}) \quad \text{Applicable for LSM decks in 24" coverage layout}$$

where: S_{avg} = shear strength (kips/ft.)
 t = base metal thickness (inches)
 L = panel length (feet)

Once again these equations are based on a limited number of test results. They are not to be used with the open profile decks.

Diaphragm shear strengths were examined only for deck panels that were fully fastened. Experimental and SDI Manual shear strength values for fully fastened open profile diaphragms are compared in Table 5.11. Experimental LSM test results are compared to calculated values using Equations 5.8-7 and 5.8-8 in Table 5.12.

It is evident, from the values in Table 5.11, that the computed shear strengths S_{u3} most closely predict the actual measured strengths for the majority of the deck types with most of the predicted values within 10% of the measured values. It should also be noted that the failure mode for most of the decks tested in this study consisted of either a fracture of a corner screw or tear-out of the deck

material at a corner fastener. This would indicate that the corner fasteners are limiting the shear strength of the deck panel. The equation for S_{u3} , equation 2.2-5 in the SDI Manual, represents shear strength controlled by the fasteners at the panel corners.

It appears that use of equation 2.2-5 of the SDI Design Manual using the modifications and procedure presented in Appendix A will produce shear strength values relatively close to values that might be expected from laboratory testing of Permanent Steel Bridge Form Decks for the open profile deck types.

Comparison of LSM test results with shear stiffness values computed using the empirical equations (Table 5.12) indicate that the equations predict shear stiffness within 10% of the measured values.

Table 5.11 Comparison of experimental and SDI shear strength values - open profile decks - fully fastened configuration.

Deck Type	S_{u1} eq. 2.2-2 (kips/ft.)	S_{u2} eq. 2.2-4 (kips/ft.)	S_{u3} eq. 2.2-5 (kips/ft.)	Measured S_u (kips/ft.)	Meas S_u / S_{u3}
BUBF18	1.12	1.48	1.43	1.70	1.19
BUBF16	1.45	2.02	1.95	2.06	1.06
BUBF14	1.57	2.13	2.06	1.87	.91
BOS816	.76	1.38	1.31	1.24	.95
BOSW18	.87	1.31	1.23	1.31	1.07
BO8.5P	1.02	1.79	1.61	1.60	.99

Table 5.12 Comparison of experimental and empirical shear strength values - LSM decks - fully fastened configuration.

Deck Type	Empirical S_u (kips/ft.)	Measured S_u (kips/ft.)	Meas. S_u / Emp. S_u
LSM1516	1.23	1.14	.93
LSM1524	.83	.91	1.10
LSM1716	1.37	1.30	.95
LSM1724	.92	.83	.90
LSM2216	.84	.89	1.06
LSM2224	.56	.60	1.07

CHAPTER 6

SUMMARY AND CONCLUSIONS

The primary objective of this project was the determination of shear stiffness and shear strength capacities of various types of Permanent Steel Bridge Deck Forms. Two different deck profile types were included in this study, namely, open profile types and flat soffit (LSM) profile types.

A preliminary investigation of the effect of deck support conditions on these capacities was also included in the study.

Finally, an attempt was made to correlate the experimentally measured capacities with commonly used design formulas.

6.1 Stiffness and Strength Capacities

6.1.1 Recommended Fastener Configurations. Permanent Steel Bridge Deck Forms were tested using combinations of the following fastener configurations:

- End fasteners at every other rib trough
- End fasteners at every rib trough
- Minimal fasteners at lap seams
- Closely spaced fasteners at lap seams

Test results showed nearly a two-fold increase in diaphragm shear stiffness when deck panels with end fasteners in every rib and closely spaced side lap fasteners were compared to deck panels using end fasteners in alternate rib troughs and minimal side lap fasteners.

It is the opinion of the authors that deck panels should always be fastened in every rib trough if the panel is to be used as a lateral bracing element. The added expense of fastener and installation costs should be more than offset by the increase in the shear stiffness of the deck diaphragm.

It is also felt that fastener spacings at the lap seams should be minimized for two reasons. For stiffness considerations, tests indicated substantial increases in shear stiffness with more closely spaced side lap fasteners. Additionally, separation of the deck sheets, at the sheet laps, may be reduced by providing more fasteners at these laps. This deck separation can be a problem during the placement of the concrete deck slab, particularly, if concrete is placed on the underlapped deck sheet first.

It is recommended that all Permanent Steel Bridge Deck Forms designed to provide lateral bracing be fastened at the panel ends in every rib trough. It is also recommended that bridge deck forms have fasteners at the lap seams spaced no more than 18 inches on center in the direction of the

deck span. For flat soffit (LSM) deck types, this side lap fastener spacing should be used at all side lap locations as shown in Figures 4.9 and 4.10. For LSM decks lighter than 20 gage, side lap fastener spacings should be reduced to a maximum of 15 inches.

6.1.2 Experimental Shear Stiffness & Shear Strength Values. Several tests were conducted using Permanent Steel Bridge Deck Forms to experimentally determine their shear stiffness and shear strength capacities. Table 5.5 of this report contains the experimental shear stiffness and shear strength for all decks tested. The fastener configurations for these tests were fully fastened configurations as recommended in the previous section. These tabulated values are actual capacities and do not include any factor of safety for design purposes.

The values listed in Table 5.5 can be used for deck panel diaphragms with or without dead load acting on the deck. It is expected that as fresh concrete fills the deck troughs, during placement of the concrete deck, the stiffness of the deck panels will increase slightly.⁴ Tests on the lighter gage LSM decks installed in 24" coverage showed a noticeable reduction in stiffness when dead load was removed. Use of the tabulated values for these unloaded decks should be considered carefully.

Values given in Table 5.5 were taken from tests conducted on deck panels approximately 8' wide. Tests conducted on wider deck panels indicated a small increase in shear strength and shear stiffness for the wider panels. Use of 8' wide test values for wider or continuous deck systems provides a conservative estimate of strength or stiffness.

All stiffness and strength values discussed in this section and presented in Table 5.5 were extracted from tests utilizing a rigid deck to test frame support method. Practical application of these capacities would require a rigid connection link between the bridge girder and the deck panel. It is commonplace to support the deck panels on a support angle that does not provide this rigid link. The flexibility of this support angle must be carefully considered if the bridge deck is to be considered as a lateral bracing element.

6.2 Support Angle Considerations

Several tests were conducted to determine what effect, if any, the method of supporting the deck panels might have on the strength and stiffness of the deck panel/angle support system. These tests used typical deck support angle systems commonly used in the industry. Results of these tests indicated that the flexibility of the deck support angle can control the overall stiffness of the deck/support system. Some deck system stiffnesses were reduced by more than 80% when typical support angles were used in lieu of a rigid connection. Shear strengths were also found to be reduced substantially for some of the decks considered.

Methods of improving the stiffness of these support angles will be essential if Permanent Steel Bridge Deck Forms are to be used as lateral bracing elements. Efforts are currently underway at The University of Texas to develop methods of increasing the stiffness of typical deck support angles.

6.3 Estimation of Stiffness and Strength

Fully fastened deck test results were compared with stiffness and strength values computed using a modified version of the design manual formulations given in the Steel Deck Institute Diaphragm Design Manual (Second Edition). The modifications of the formulations required for use with Permanent Steel Bridge Deck Forms are presented in Appendix A. The comparisons presented in Chapter 5 indicate that the modified design formulations produce reasonably reliable stiffness and strength values for open profile deck panels fastened as recommended in Section 6.1.1 above.

It should be noted that the open profile deck types are very similar to the decks used in the testing program that led to the development of the SDI Manual, consequently, the SDI design formulations can be applied with only minor modifications. Because of this similarity and the reasonably close comparisons noted above, the authors feel confident in the use of the SDI equations for the open profile decks.

Flat soffit (LSM) decks, on the other hand, do not possess the profile similarity with the SDI decks. The LSM deck profile presents several areas of confusion in the use of the SDI Manual procedure, consequently, use of the SDI Manual equations is not recommended for the LSM decks. Empirical equations, presented in Chapter 5, were derived from the LSM deck test results to provide a method of estimating LSM shear stiffness and shear strength capacities. The reader should be aware of the fact that these empirical equations are based on a very limited number of tests and should be used accordingly.

APPENDIX A

SDI DIAPHRAGM STIFFNESS

Shear Stiffness Equation

The shear stiffness of a corrugated diaphragm is defined by equation 3.3-3 of the Steel Deck Institute Diaphragm Design Manual (Second Edition).⁴

$$G' = Et/(2(1+\nu)(s/d)+\phi D_n + C) \quad (\text{SDI Eq. 3.3-3})$$

where:	E	=	Modulus of elasticity	=	29500 ksi
	ν	=	Poisson's ratio	=	0.3
	D_n	=	Warping constant		
	C	=	Connector slip parameter		
	s	=	Girth of corrugation per rib, inches	(see Figure 5.1)	
	d	=	Corrugation pitch, inches	(see Figure 5.1)	
	t	=	Base metal thickness, inches		
	ϕ	=	1.0 for simple span deck sheets		

Connector Slip Parameter

Equation 3.3-1 of the Second Edition of the SDI Manual represents a simplified equation for the connector slip parameter. This simplified equation is based on the assumption that the number of intermediate edge connectors (n_e) are equal to the number of side lap fasteners (n_s). For bridge systems there are no intermediate edge connectors, consequently, n_e does not equal n_s and the simplified equation is not useable. For this reason, the more exact equation for C will be used. This equation can be found on page 28 of the Steel Deck Institute Diaphragm Design Manual (First Edition)³ and is reproduced below.

$$C = [24EtLS_f/a] \left[\frac{(n_{sh}-1)}{(2\alpha_1 + n_p\alpha_2 + 2n_sS_f/S_s)} + \frac{1}{(2\alpha_1 + n_p\alpha_2 + n_e)} \right]$$
$$\alpha_1 = \sum x_e / w_{sh}$$

where:	L	=	Panel length (deck sheet span length), feet
	a	=	Overall diaphragm panel width, inches
	n_{sh}	=	Number of individual deck sheets in panel
	n_s	=	Number of side lap fasteners per seam
	w_{sh}	=	Individual deck sheet width, inches
	n_p	=	Number of purlins (zero for all tests)
	α_2	=	0, for no purlins
	n_e	=	Number of edge connectors (zero for all tests)
	x_e	=	Distance from individual deck sheet centerline to any fastener in a deck sheet at the end fasteners, inches

Structural connector flexibility, S_f , and side lap connector flexibility, S_s , are defined in the second edition of the SDI Manual by equations 4.5.1-1 and 4.5.1-2 respectively.

$$\begin{aligned} S_f &= 0.0013/t^{0.5} && (\text{in./kip}) \\ S_s &= 0.003/t^{0.5} && (\text{in./kip}) \end{aligned}$$

Diaphragm geometries required for use in the shear stiffness and connector slip parameter equations are shown in Figure A.1.

Warping Constant

The warping constant is defined in the second edition of the SDI Manual as:

$$D_n = D/12L \quad (\text{SDI Eq. 3.3-2})$$

The D-values required in this equation are developed in Appendix IV of the SDI Manual. Values are established for DW1 through DW4 representing D-values for end fasteners located in each, alternate, every third, and fourth valleys respectively. The D-value equations are presented below. Deck profile dimensions required in the D-Value equations are defined in Figure 5.1. It should be noted that all radius corners are squared-off and formed deck stiffeners are neglected for the purposes of determining the deck profile dimensions. Deck profile dimensions for decks included in this study are shown in Table A.1.

Table A.1 Deck profile dimensions - open profile decks included in study.

Deck Type	t (in.)	h (in.)	d (in.)	e (in.)	f (in.)	g (in.)	w (in.)	s (in.)
BUBF18	0.048	2.5	6.5	0.69	2.66	1.23	2.81	9.66
BUBF16	0.060	2.0	6.0	1.00	2.00	1.00	2.25	8.50
BUBF14	0.072	2.5	6.5	0.69	2.66	1.23	2.81	9.66
BOS816	0.062	3.0	8.0	1.00	5.50	0.25	3.00	13.50
BOSW18	0.047	2.5	8.0	1.13	3.25	1.25	2.81	11.13
BO8.5P	0.062	2.0	8.5	1.14	4.78	0.72	2.12	11.30

All profile dimensions were taken from dimensional drawings furnished by the deck manufacturers except thickness, t. Thicknesses listed were actual measured uncoated thickness taken from test specimens.

D-Value Equations:

$$\begin{aligned}
WT &= 4f^2(f+w) \\
WB &= 16e^2(2e+w) \\
PW &= 1/t^{1.5} \\
A &= 2e/f \\
D1 &= h^2(2w+3f)/3 \\
D2 &= D1/2 \\
V &= 2(e+w)+f \\
D3 &= (h^2/12d^2)((V)(4e^2-2ef+f^2)+d^2(3f+2w)) \\
\\
C1 &= 1/(D3-D2/2) \\
C2 &= 1/(e(D2/f)+D3) \\
C3 &= 1/((0.5+A)D2+D3) \\
C4 &= A/(e(D1/f)+D2) \\
C5 &= A/((0.5+A)D1+D2) \\
C6 &= 1/((0.5+A)D1+D3+D2/2) \\
\\
D4[1] &= (24f/C1)(C1/WT)^{0.25} \\
D4[2] &= (24f/C2)(C2/WT)^{0.25} \\
D4[3] &= (24f/C3)(C3/WT)^{0.25} \\
D4[4] &= (48e/C4)(C4/WB)^{0.25} \\
D4[5] &= (48e/C5)(C5/WB)^{0.25} \\
D4[6] &= (24f/C6)(C6/WT)^{0.25} \\
\\
G4[1] &= D4[1] \\
G4[2] &= 2(D4[2])+A(D4[4]) \\
G4[3] &= 2(D4[3])+D4[6]+2A(D4[5]) \\
\\
C41 &= A/((1.5A+1)D1+D2) \\
C42 &= 1/(D3+(1.5A+1)D2) \\
C43 &= A/((2A+1)D1+2(D2)) \\
C44 &= 1/((1.5A+1)D1+(0.5A+1)D2+D3) \\
\\
D42 &= (24f/C42)(C42/WT)^{0.25} \\
D44 &= (24f/C44)(C44/WT)^{0.25} \\
D41 &= (48e/C41)(C41/WB)^{0.25} \\
D43 &= (48e/C43)(C43/WB)^{0.25} \\
G44 &= 2(D42+D44)+A(2(D41)+D43) \\
\\
DW1 &= (G4[1])(f/d)(PW) \\
DW2 &= (G4[2])(f/2d)(PW) \\
DW3 &= (G4[3])(f/3d)(PW) \\
DW4 &= (G44)(f/4d)(PW)
\end{aligned}$$

SDI DIAPHRAGM STRENGTH

Shear Strength Equations

All equations utilized in the determination of the SDI Shear Strengths were taken from the Steel Deck Institute Diaphragm Design Manual (Second Edition).⁴ The three strength equations developed in the SDI Manual are:

$$\begin{aligned} S_{u1} &= (2\alpha_1 + n_p\alpha_2 + n_e)Q_f/L && \text{(SDI Eq. 2.2-2)} \\ S_{u2} &= (2A(\lambda-1) + B)Q_f/L && \text{(SDI Eq. 2.2-4a)} \\ S_{u3} &= (N^2B^2/(L^2N^2 + B^2))^{0.5}Q_f && \text{(SDI Eq. 2.2-5)} \end{aligned}$$

SDI Equation 2.2-5 assumes that λ (see below) approaches unity. This assumption is not true for the deck profiles included in this study. Equation 2.2-5 is expanded with the λ term included and is presented below. This expanded equation should be used to determine S_{u3} for Permanent Steel Bridge Deck Forms.

$$\begin{aligned} S_{u3} &= (Q_f^2/((L/(2A(\lambda-1)+B))^2 + (1/N)^2))^{0.5} && \text{(SDI Eq. 2.2-5 modified)} \\ B &= n_s\alpha_s + (1/w_{sh}^2)(2n_p\Sigma x_p^2 + 4\Sigma x_e^2) \\ \lambda &= 1 - hL_v/(240(t)^{0.5}) \\ \alpha_s &= Q_s/Q_f \\ Q_s &= 115s_d t, \text{ kips} && \text{(SDI Eq. 4.5-2)} \\ Q_f &= 1.25F_y t(1 - 0.005F_y), \text{ kips} && \text{(SDI Eq. 4.5-1)} \end{aligned}$$

where:

$$\begin{aligned} \alpha_1 &= \Sigma x_e/w_{sh} \\ n_p &= \text{Number of purlins (zero for all tests)} \\ \alpha_2 &= 0, \text{ for no purlins} \\ n_e &= \text{Number of edge connectors (zero for all tests)} \\ L &= \text{Panel length, feet} \\ A &= 1 \text{ for single fasteners at panel edges (all tests)} \\ h &= \text{Deck profile depth, inches (see Figure 5.1)} \\ L_v &= \text{Purlin spacing} = L \text{ for all tests, feet} \\ t &= \text{Base metal thickness, inches} \\ n_s &= \text{Number of side lap fasteners per seam} \\ w_{sh} &= \text{Individual deck sheet width, inches} \\ x_e &= \text{Distance from individual deck sheet centerline to any fastener in a} \\ &\quad \text{deck sheet at the end fasteners, inches} \\ \Sigma x_p^2 &= 0, \text{ for no purlins} \\ s_d &= \text{Major diameter of side lap screw, inches} \\ F_y &= \text{Yield strength of deck material, ksi} \\ N &= \text{Number of end fasteners per foot} \end{aligned}$$

Definitions of these properties are included in Figure A.1.

DEVELOPMENT OF FIGURE A.1

The open profile type deck panels have basically the same profile and lap seam configuration as the deck types included in the SDI testing program which led to the development of the SDI Design Manual.⁴ Consequently, SDI equations can be used directly to compute approximate shear strengths and shear stiffnesses for the open profile decks. Figure A.1 defines several of the diaphragm geometric properties that are used in the SDI equations.

The flat soffit (LSM) type decks have profiles and lap seam configurations that are considerably different from the SDI decks. The two main differences found in the LSM decks are the covers which box either one or both of the open troughs and the multiple number of side lap fastener rows which occur in the LSM decks. These differences lead to confusion in the choice of individual deck sheet width and number of side lap fasteners per seam. The SDI procedures for computing shear stiffness and shear strength, which are presented in this Appendix, are not usable with LSM type decks.

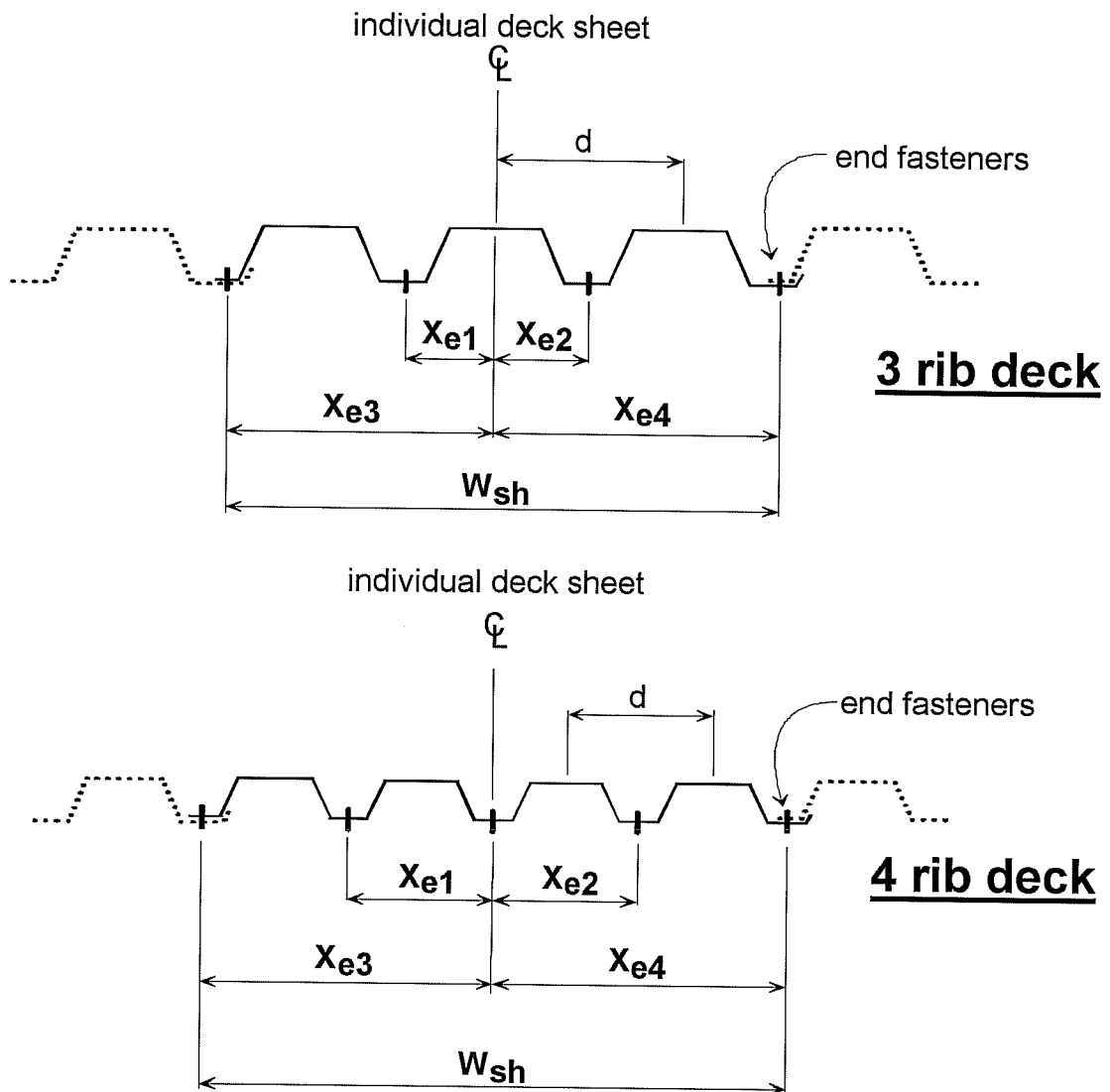

Figure A.1 Open profile diaphragm geometries.

d = corrugation pitch, inches
 W_{sh} = individual deck sheet width, inches
 x_e = distance from individual deck sheet centerline to any fastener in a deck sheet at the end fasteners, inches
 $\Sigma x_e = x_{e1} + x_{e2} + x_{e3} + x_{e4} + \dots$
 $\Sigma x_e^2 = x_{e1}^2 + x_{e2}^2 + x_{e3}^2 + x_{e4}^2 + \dots$

EXAMPLE OF SDI SHEAR STIFFNESS CALCULATION

Deck Profile Type - BUBF18 in Fully Fastened Configuration
(Refer to Figure 4.6)

Connector Slip Parameter

$$\begin{aligned}
 L &= 8.0 \text{ feet} \\
 a &= 104 \text{ inches} \\
 n_{st} &= 4 \\
 n_s &= 5 \\
 w_{sh} &= 26 \text{ inches} \\
 n_p &= 0 \\
 \alpha_2 &= 0 \\
 n_e &= 0 \\
 t &= 0.048 \text{ inches} \\
 s &= 2(.69)+2(2.81)+2.66 = 9.66 \text{ inches} \\
 d &= 6.5 \text{ inches}
 \end{aligned}$$

$$\begin{aligned}
 S_f &= 0.0013/(0.048)^{.5} = 0.00593 \text{ in./kip} \\
 S_s &= 0.003/(0.048)^{.5} = 0.01369 \text{ in./kip} \\
 \alpha_1 &= (6.5+6.5+13+13)/26 = 1.5
 \end{aligned}$$

$$\begin{aligned}
 C &= [(24)(29500)(0.048)(8)(0.00593)/(104)]*[\quad] \\
 [\quad] &= [(4-1)/(2*1.5+0+2*5*0.00593/0.01369)]+[(1)/(2*1.5+0+0)]
 \end{aligned}$$

$$C = 11.52$$

Warping Constant

D-Values :

$$\begin{aligned}
 WT &= (4)(2.66)^2(2.66+2.81) = 154.814 \\
 WB &= (16)(0.69)^2[(2)(0.69)+2.81] = 31.918 \\
 PW &= 1/(0.048)^{1.5} = 95.091 \\
 A &= (2)(0.69)/(2.66) = 0.519 \\
 D1 &= (2.5)^2[(2)(2.81)+(3)(2.66)]/3 = 28.333 \\
 D2 &= (28.333)/2 = 14.167 \\
 V &= 2(0.69+2.81)+2.66 = 9.66 \\
 D3 &= (1/12)(2.5^2/6.5^2)\{[9.66][(4)(0.69)^2-(2)(0.69)(2.66)+(2.66)^2]+ \\
 &\quad 6.5^2[(3)(2.66)+(2)(2.81)]\} = 7.716
 \end{aligned}$$

$$\begin{aligned}
C1 &= 1/(7.716-14.167/2) = 1.582 \\
C2 &= 1/[0.69(14.167/2.66)+7.716] = 0.088 \\
C3 &= 1/[(0.5+0.519)(14.167)+7.716] = 0.045 \\
C4 &= 0.519/[0.69(28.333/2.66)+14.167] = 0.024 \\
C5 &= 0.519/[(0.5+0.519)(28.333)+14.167] = 0.012 \\
C6 &= 1/[(0.5+0.519)(28.333)+7.716+14.167/2] = 0.023 \\
\\
D4[1] &= [(24)(2.66)/(1.582)][(1.582/154.814)^{0.25}] = 12.832 \\
D4[2] &= [(24)(2.66)/(0.088)][(0.088/154.814)^{0.25}] = 112.213 \\
D4[3] &= [(24)(2.66)/(0.045)][(0.045/154.814)^{0.25}] = 184.777 \\
D4[4] &= [(48)(0.69)/(0.024)][(0.024/31.918)^{0.25}] = 227.725 \\
D4[5] &= [(48)(0.69)/(0.012)][(0.012/31.918)^{0.25}] = 382.985 \\
D4[6] &= [(24)(2.66)/(0.023)][(0.023/154.814)^{0.25}] = 307.425 \\
\\
G4[1] &= 12.832 \\
G4[2] &= (2)(112.213)+(0.519)(227.725) = 342.5692 \\
G4[3] &= (2)(184.777)+307.425+(2)(0.519)(382.985) = 1074.363 \\
\\
C41 &= (0.519)/\{(1.5)(0.519)+1\}[28.33]+14.167\} = 0.00804 \\
C42 &= 1/\{7.716+[(1.5)(0.519)+1]14.167\} = 0.03038 \\
C43 &= (0.519)/\{(2)(0.519)+1\}28.33+(2)(14.167)\} = 0.00603 \\
C44 &= 1/\{[(1.5)(0.519)+1]28.33+[(0.5)(0.519)+1]14.167+7.716\} = 0.01317 \\
\\
D42 &= [(24)(2.66)/(0.3038)][0.03038/154.814]^{0.25} = 248.658 \\
D44 &= [(24)(2.66)/(0.01317)][0.01317/154.814]^{0.25} = 465.575 \\
D41 &= [(48)(0.69)/(0.00804)][0.00804/31.918]^{0.25} = 519.100 \\
D43 &= [(48)(0.69)/(0.00603)][0.00603/31.918]^{0.25} = 644.102 \\
G44 &= 2(248.658+465.575)+(0.519)[(2)(519.1)+644.102] = 2301.24 \\
\\
DW1 &= (12.832)(2.66/6.5)(95.091) = 499.350 \\
DW2 &= (342.5692)(2.66/(2)(6.5))(95.091) = 6665.376 \\
DW3 &= (1074.363)(2.66/(3)(6.5))(95.091) = 13935.94 \\
DW4 &= (2301.24)(2.66/(4)(6.5))(95.091) = 22387.65
\end{aligned}$$

For a fully fastened deck panel (fasteners in every trough) use DW1 as the D-value for use in the warping constant equation.

$$D_n = D/12L = 499.350/(12)(8) = 5.20$$

Shear Stiffness

Assume open ended corrugated deck elements, therefore, the warping constant is included in the shear stiffness calculation:

$$G' = Et / (2(1+\nu)(s/d) + D_n + C)$$

$$G' = (29500)(0.048) / [2(1+0.3)(9.66/6.5) + 5.2 + 11.52]$$

$$G' = 68.8 \text{ kips/inch (open)}$$

Assume fully closed end corrugated deck elements such that warping of the deck ends are restrained ($D_n = 0$):

$$G' = (29500)(0.048) / [2(1+0.3)(9.66/6.5) + 0 + 11.52]$$

$$G' = 92.1 \text{ kips/inch (closed)}$$

EXAMPLE OF SDI SHEAR STRENGTH CALCULATION

Deck Profile Type - BUBF18 in Fully Fastened Configuration
(Refer to Figure 4.6)

$$\begin{aligned}
 \alpha_1 &= (6.5+6.5+13+13)/26 = 1.5 \\
 n_p &= 0 \\
 \alpha_2 &= 0 \\
 n_e &= 0 \\
 L &= 8.0 \text{ feet} \\
 A &= 1 \\
 h &= 2.5 \text{ inches} \\
 L_v &= 8.0 \text{ feet} \\
 t &= 0.048 \text{ inches} \\
 n_s &= 5 \\
 w_{sh} &= 26 \text{ inches} \\
 \Sigma X_p^2 &= 0 \\
 s_d &= 0.24 \text{ inches} \\
 F_y &= 92 \text{ ksi (dynamic yield stress)} \\
 N &= 1.85
 \end{aligned}$$

$$\begin{aligned}
 \Sigma X_e^2 &= (6.5)^2 + (6.5)^2 + (13)^2 + (13)^2 = 422.5 \\
 Q_s &= (115)(0.24)(0.048) = 1.325 \\
 Q_f &= (1.25)(92)(0.048)[1 - (0.005)(92)] = 2.98 \\
 \alpha_s &= 1.325/2.98 = 0.445 \\
 \lambda &= 1 - (2.5)(8)/(240)(0.048)^{0.5} = 0.6196 \\
 B &= (5)(0.445) + [0 + (4)(422.5)]/(26)^2 = 4.725
 \end{aligned}$$

$$\begin{aligned}
 S_{u1} &= [(2)(1.5) + 0 + 0][2.98]/8 = 1.12 \text{ kips/ft.} \\
 S_{u2} &= [(2)(1)(0.6196 - 1) + 4.725][2.98]/8 = 1.48 \text{ kips/ft.} \\
 S_{u3} &= [2.98^2 / ((8/(2 \cdot 1 \cdot (0.6196 - 1) + 4.725))^2 + (1/1.85)^2)]^{0.5} \\
 &= 1.43 \text{ kips/ft.}
 \end{aligned}$$

BIBLIOGRAPHY

1. American Association of State Highway and Transportation Officials (AASHTO), Standard Specifications for Highway Bridges, Fifteenth Edition, Washington D.C., 1992.
2. American Institute of Steel Construction, Manual of Steel Construction, Load and Resistance Factor Design, First Edition, USA, 1990.
3. Luttrell, Larry D., Steel Deck Institute Diaphragm Design Manual for the Steel Deck Institute, First Edition, St. Louis, Missouri, 1981.
4. Luttrell, Larry D., Steel Deck Institute Diaphragm Design Manual, Second Edition, Canton, Ohio, 1987.
5. Davies, J.M. and Bryan, E.R., Manual of Stressed Skin Diaphragm Design, USA, 1982.
6. Bryan, Eric R. and El-Dakhakhni, Wagih M., "Shear Flexibility and Strength of Corrugated Decks", Journal of the Structural Division Proceedings of the American Society of Civil Engineers, November, 1968.
7. Salmon, Charles G. and Johnson, John E., Steel Structures, Design and Behavior, Emphasizing Load and Resistance Factor Design, Third Edition, USA, 1990.
8. Heagler, Richard P. and Luttrell, Larry D., "How to Fasten Steel Deck-Update and Review", Modern Steel Construction, Number 1, 1988.