

Reference Copy CTR
Does not Circulate

CTR 3-5-81-305-1F

STRENGTH AND BEHAVIOR OF BOLT
INSTALLATIONS ANCHORED IN
CONCRETE PIERS

J. O. Jirsa, N. T. Cichy, M. R. Calzadilla,
W. H. Smart, M. P. Pavlucik,
and J. E. Breen

RESEARCH REPORT 305-1F

PROJECT 3-5-81-305

CENTER FOR TRANSPORTATION RESEARCH

BUREAU OF ENGINEERING RESEARCH
THE UNIVERSITY OF TEXAS AT AUSTIN
NOVEMBER 1984

1. Report No. FHWA/TX-85/51+305-1F	2. Government Accession No.	3. Recd  L007282
4. Title and Subtitle STRENGTH AND BEHAVIOR OF BOLT INSTALLATIONS ANCHORED IN CONCRETE PIERS	5. Report Date November 1984	6. Performing Organization Code
	8. Performing Organization Report No. Research Report 305-1F	
7. Author(s) J. O. Jirsa, N. T. Cichy, M. R. Calzadilla, W. H. Smart, M. P. Pavlucik, and J. E. Breen	10. Work Unit No.	
9. Performing Organization Name and Address Center for Transportation Research The University of Texas at Austin Austin, Texas 78712-1075	11. Contract or Grant No. Research Study 3-5-81-305	
	13. Type of Report and Period Covered Final	
12. Sponsoring Agency Name and Address Texas State Department of Highways and Public Transportation; Transportation Planning Division P. O. Box 5051 Austin, Texas 78763	14. Sponsoring Agency Code	
	15. Supplementary Notes Study conducted in cooperation with the U. S. Department of Transportation, Federal Highway Administration Research Study Title: "Strength of Anchor Bolt Groups"	
16. Abstract <p>In this study, the primary objective was to investigate the strength and behavior of anchor bolt installations. In one phase, high strength anchor bolt groups embedded in reinforced concrete piers were investigated. Bolts with a 1-3/4-in. diameter and a yield stress of 105 ksi were used. The anchorage length was 20 bar diameters and a nut and two or three standard washers provided bearing at the end. From the tests, the effects of bolt spacing and clear cover on the strength of the anchor bolt groups were determined. Center-to-center bolt spacing ranged from 4.0 in. to 13.5 in.; clear cover ranged from 2.4 in. to 7.4 in. In general, it was confirmed that as bolt spacing, clear cover, or the combination of both, is increased, the group capacity is also increased. Also, groups with shallow clear cover failed very abruptly, while groups with large cover underwent a significant amount of slip while maintaining their load capacity before and after ultimate was reached.</p> <p>In the second phase, six single bolt tests were performed. The clear concrete cover to each bolt was maintained at 5-5/8 in. Two different steel grades were used in manufacturing the bolts (55 and 105 ksi). Anchorage for the bolts consisted of a 90° bend in the bolt, a 90° bend plus steel strap, or a nut and steel strap combination. In this series of tests, the effects of the bolt material and the type of anchorage on the tensile capacity of the installations were determined. A post-tension test was performed on a two-bolt group as part of the single bolt test series.</p>		
17. Key Words bolt installations, anchored, concrete piers, strength, behavior, spacing, clear cover, group, single	18. Distribution Statement No restrictions. This document is available to the public through the National Technical Information Service, Springfield, Virginia 22161.	
19. Security Classif. (of this report) Unclassified	20. Security Classif. (of this page) Unclassified	21. No. of Pages 154
22. Price		

STRENGTH AND BEHAVIOR OF BOLT INSTALLATIONS
ANCHORED IN CONCRETE PIERS

by

J. O. Jirsa
N. T. Cichy
M. R. Calzadilla
W. H. Smart
M. P. Pavluvcik
J. E. Breen

Research Report 305-1F

Research Report 3-5-81-305
Strength of Anchor Bolt Groups

Conducted for

Texas

State Department of Highways and Public Transportation

In Cooperation with the
U. S. Department of Transportation
Federal Highway Administration

by

CENTER FOR TRANSPORTATION RESEARCH
BUREAU OF ENGINEERING RESEARCH
THE UNIVERSITY OF TEXAS AT AUSTIN

November 1984

The contents of this report reflect the views of the authors who are responsible for the facts and accuracy of the data presented herein. The contents do not necessarily reflect the official views or policies of the Federal Highway Administration. This report does not constitute a standard, specification, or regulation.

There was no invention or discovery conceived or first actually reduced to practice in the course of or under this contract, including any art, method, process, machine, manufacture, design or composition of matter, or any new and useful improvement thereof, or any variety of plant which is or may be patentable under the patent laws of the United States of America or any foreign country.

P R E F A C E

In the report, the results of tests on the strength of anchor bolt groups and typical anchor bolt installations used in transportation structures are presented. The objective was to provide data which could be used for design of such anchorages. The work is an extension of earlier projects (29, 55, and 88) on anchor bolts which were sponsored by the State Department of Highways and Public Transportation.

The project was sponsored by the State Department of Highways and Public Transportation and the Federal Highway Administration, and was administered by the Center for Transportation Research at The University of Texas at Austin. Liaison with the sponsoring agencies has been maintained through Messrs. Warren Grasso, L. E. Howell, Jr., and J. M. Murchison of the SDHPT and Mr. T. E. Strock of the Federal Highway Administration.

Early in the study, Mr. Robert L. Reed, Engineer of Bridge Design, was instrumental in providing guidance as to the selection of typical anchor bolt installations for testing. In addition, a number of other state highway departments provided plans and suggestions for the project. Special acknowledgment is due Mr. P. R. C. Cassano, California Department of Transportation; Mr. Carl E. Thunman, Jr., Illinois Department of Transportation; Mr. E. V. Hourigan, New York State Department of Transportation; and Mr. Charles H. Wilson, Wyoming State Highway Department.

S U M M A R Y

In this study, the primary objective was to investigate the strength and behavior of anchor bolt installations. In one phase, high strength anchor bolt groups embedded in reinforced concrete piers were investigated. Bolts with a 1-3/4 in. diameter and a yield stress of 105 ksi were used. The anchorage length was 20 bar diameters and a nut and two or three standard washers provided bearing at the end. From the tests, the effects of bolt spacing and clear cover on the strength of the anchor bolt groups were determined. Center-to-center bolt spacing ranged from 4.0 in. to 13.5 in.; clear cover ranged from 2.4 in. to 7.4 in. In general, it was confirmed that as bolt spacing, clear cover, or the combination of both, is increased, the group capacity is also increased. Also, groups with shallow clear cover failed very abruptly, while groups with large cover underwent a significant amount of slip while maintaining their load capacity before and after ultimate was reached.

In the second phase, six single bolt tests were performed. The clear concrete cover to each bolt was maintained at 5-5/8 in. Two different steel grades were used in manufacturing the bolts (55 and 105 ksi). Anchorage for the bolts consisted of a 90° bend in the bolt, a 90° bend plus steel strap, or a nut and steel strap combination. In this series of tests, the effects of the bolt material and the type of anchorage on the tensile capacity of the installations were determined. A post-tension test was performed on a two-bolt group as part of the single bolt test series.

IMPLEMENTATION

Bolt Groups

The bolt group interaction and strength reduction were evaluated by comparing the average test capacity with the predicted capacity of isolated bolts with similar geometry. Bolts with a yield stress of 105 ksi and a diameter of 1-3/4 in. were tested. It was observed that as bolt spacing decreased, the reduction in strength significantly increased. From an analysis of the available data, a modification to Hasselwander's equation was produced for the nominal tensile capacity for an anchor bolt in a bolt group based on failure of the concrete. For design, the following is proposed:

For anchor bolt groups embedded in reinforced concrete piers and loaded in pure tension, design of pier shall be based on:

$$T_u \leq \phi T_n$$

where T_u is the factored bolt tensile capacity, ϕ is a capacity reduction factor of 0.75, and T_n is the nominal tensile capacity of an anchor bolt (lbs) with embedment length not less than $12(D_w - D)$, computed by:

$$T_n \leq A_{sm} f_y < 140 A_b \sqrt{f'_c} [0.7 + \ln(2C/(D_w - D))] K_s$$

- A_b = net bearing area, in.², not greater than $4D^2$ nor less than the projecting area of the nut.
- A_{sm} = mean tensile area of anchor bolt, in.²
- D = bolt diameter, in.
- D_w = the diameter, in., of the washer or anchor plate; where a continuous template or anchor plate is used for a group of anchor bolts, the washer diameter may be taken as the diameter of a circle concentric with the bolt and inscribed within the template or anchor plate. D_w shall not be taken greater than 8 times the thickness of the washer, plate or template.
- C = clear cover to bolt, in.
- K_s = spacing reduction factor = $(0.02S + 0.40) \leq 1.0$
- S = center-to-center bolt spacing, in.
- f'_c = concrete compressive strength, psi
- f_y = yield strength of the bolt material, psi

Single Bolts

In the single bolt test series, the effectiveness of three different anchorage types was examined. A nut/steel strap anchorage proved more effective than 90° bends or bends with straps in developing strength. Post-tensioning a bolt installation was found to be difficult and produced much less stress than anticipated.

From observations of the tests, several conclusions can be drawn: (1) a significant percentage of existing highway anchor bolt installations probably do not have sufficient cover to provide any ductility in case of overload, (2) designing piers with enough cover to yield large diameter high strength bolts ($f_y = 105$ ksi) would probably be uneconomical, and (3) designing piers to develop large diameter bolts of lower strength material or high strength small diameter bolts might prove to be more practical.

C O N T E N T S

Part		Page
1	INTRODUCTION	1
1.1	Background	1
1.2	Strength of Isolated Anchor Bolts	1
1.3	Behavior of Bolts in a Group	2
1.4	Objective and Scope	5
2	SURVEY OF APPLICATIONS AND DESIGN DATA	7
2.1	Typical Anchor Bolt Applications and Design Data	7
2.2	Literature Review--Design	7
3	EXPERIMENTAL PROGRAM - BOLT GROUPS	23
3.1	Introduction	23
3.2	Description of Tests	27
3.2.1	Four-Bolt Groups	27
3.2.2	Two-Bolt Groups	30
3.2.3	Three-Bolt Groups	30
3.3	Materials	30
3.3.1	Anchor Bolts, Nuts, Washers	33
3.3.2	Concrete	33
3.3.3	Steel Reinforcement	33
3.4	Fabrication	33
3.5	Instrumentation	35
3.5.1	Strain Gages	35
3.5.2	Slip Wires	42
3.6	Loading System	42
3.7	Test Procedure	51
4	TEST RESULTS	53
4.1	Introduction	53
4.2	General Response under Loading	56
4.3	Load-Slip Relationships	56
4.4	Crack Patterns	71
4.4.1	Four-Bolt Groups	71
4.4.2	Two-Bolt Groups	75
4.4.3	Three-Bolt Groups	75
4.5	Effect of Transverse Reinforcement, Spirals, Ties	75
5	COMPARISON OF BOLT GROUP TESTS	87
5.1	Introduction	87
5.2	Effect of Bolt Spacing	87

Part	Page
5.3 Effect of Clear Cover	87
5.4 Center Bolt Performance in Three-Bolt Groups	96
5.5 Effect of Bolt Staggering	96
5.6 Effect of Reduced Bearing Area	101
 6 DESIGN EQUATION FOR ANCHOR BOLT GROUPS	 103
6.1 Introduction	103
6.2 Single Bolt Capacity	103
6.3 Design Equation	106
 7 SINGLE BOLT TEST PROGRAM	 109
7.1 Introduction	109
7.2 Experimental Program	113
7.3 Test Results	117
7.3.1 Load-Slip Relationships	117
7.3.2 Surface Crack Development	117
7.4 Analysis of Results	123
7.4.1 Anchorage Type	123
7.4.2 Bolt Material	123
7.4.3 Calculated Strength	123
7.5 Post-tension Test	128
 8 SUMMARY AND CONCLUSIONS	 135
8.1 Summary	135
8.2 Conclusions	136
 REFERENCES	 139

T A B L E S

Table		Page
3.1	SDHPT standard plans--cantilever overhead sign support structure	25
3.2	Description of tests	28
4.1	Bolt forces at ultimate on group	58
6.1	Strength reduction of bolts in a group	104
7.1	Summary of single-bolt test series	114
7.2	Effective bearing area for tests SB-5 and TB-1	127

F I G U R E S

Figure		Page
1.1	Conditions around the anchorage after formation of the cone of crushed concrete	3
1.2	Comparison of lead slip-lead stress curves of bolts in a group	4
2.1	Overhead sign support (Wyoming Highway Department)	8
2.2	Overhead sign support (California Department of Transportation)	9
2.3	Overhead sign support (New York Department of Transportation)	10
2.4	Overhead sign support frame (Illinois Department of Transportation)	11
2.5	Light standard support (Texas State Department of Highways and Public Transportation)	12
2.6	Light standard support on concrete parapet (Illinois Department of Transportation)	13
2.7	Traffic signal and light standard support (California Department of Transportation)	14
2.8	Bridge bearing connection to pier cap (California Department of Transportation)	15
2.9	Effect of bolt spacing on the lateral resistance of anchor bolt pairs (Ref. 6)	19
2.10	Effective stress area for anchorage pullout (Ref. 3) ..	21
3.1	SDHPT details - cantilever overhead sign support base .	24
3.2	Orientation of loading on bolt group in circular pier .	26
3.3	Typical specimen geometry and details	29
3.4	Section of pier; 2-bolt groups	31
3.5	Square pier geometry and details	32
3.6	Spiral cage in place	34

Figure		Page
3.7	Bolts inside formwork	36
3.8	Formwork assembly prior to casting	36
3.9	Inside of tube prior to casting (2-bolt group)	37
3.10	Square pier formwork	38
3.11	Reinforcing cage inside formwork	38
3.12	Location of bolt instrumentation	39
3.13	Strain gages on spiral and longitudinal reinforcement .	40
3.14	Location of transverse reinforcement instrumentation ..	41
3.15	Bolt instrumentation	43
3.16	Slip measurement device mounted on specimen	44
3.17	Test frame--plan view	45
3.18	Test frame--elevation	46
3.19	Specimen--loading beam interface	48
3.20	Free body diagrams of test setup	49
3.21	Test setup prior to testing	50
4.1	Nomenclature for bolt group installation	54
4.2	Consistency of test data with overall equilibrium (2-bolt groups)	55
4.3	Bolt stress variation during testing	57
4.4	Stress variation along bolt	59
4.5	Load-slip curves, SC1 and SC2	60
4.6	Load-slip curves, SC3 and SC4	61
4.7	Load-slip curves, NOW and SC6	62
4.8	Load-slip curves, SC7 and SC8	63
4.9	Load-slip curves, STG1 and STG2	64

Figure		Page
4.10	Load-slip curves, TB1 and TB3	65
4.11	Load-slip curves, TB4 and TB5	66
4.12	Load-slip curves, TB6 and TB7	67
4.13	Load-slip curves, TB8 and TB9	68
4.14	Load-slip curves, 3B-1 and 3B-3	69
4.15	Load-slip curves, 3B-2, 3B-4 and 3B-5	70
4.16	Cone of crushed and compacted concrete in front of anchorage device	72
4.17	Anchor bolts after removal from test specimen showing cone of compacted concrete	73
4.18	Crack pattern, SC7	74
4.19	Splitting and uplift of cover, SC6	76
4.20	Crack patterns, staggered bolts: STG1	77
4.21	Crack development: test TB5	78
4.22	Effect of cover on cracking at ultimate	79
4.23	Cracking, 3-bolt group, 3B-2	80
4.24	Cracking, 3-bolt group, 3B-3	81
4.25	Strains in spiral reinforcement, TB5	82
4.26	Strains in spiral reinforcement, TB9	83
4.27	Tie strains, 3B-3	85
5.1	Bolt tension vs. lead slip for 2-bolt and upper bolts in 4-bolt groups	88
5.2	Effect of bolt spacing: TB1, TB5, TB8	89
5.3	Effect of bolt spacing: TB4, TB7	90
5.4	Effect of bolt spacing: SC2, SC4	91
5.5	Effect of clear cover: TB5, TB7, TB9	92

Figure		Page
5.6	Effect of clear cover: TB1, TB4	93
5.7	Effect of clear cover: SC6, SC8	94
5.8	Effect of clear cover: SC1, SC4	95
5.9	Average stress-slip curves for 3-bolt groups	97
5.10	Stress-slip curve for center bolts of 3-bolt groups ...	98
5.11	Effect of bolt staggering: SC1, STG1	99
5.12	Effect of bolt staggering: SC2, STG2	100
5.13	Effect of reduced bearing area: SC6, NOW	102
6.1	Strength reduction of bolts in a group	105
7.1	SDHPT specifications for traffic signal foundations ...	110
7.2	SDHPT specifications for overhead sign support foundations	111
7.3	Anchorage details	112
7.4	Specimen 1	115
7.5	Specimen 2	116
7.6	Bolt instrumentation	118
7.7	Load-slip curves for tests SB1 and SB2	119
7.8	Load-slip curves for tests SB3 and SB4	120
7.9	Load-slip curves for tests SB5 and SB6	121
7.10	Crack pattern of test SB3	122
7.11	Crack pattern of test SB5	122
7.12	Crack pattern of test TB1	124
7.13	Load-slip curves for tests SB1, SB3 and SB5	125
7.14	Load-slip curves for tests SB2, SB4 and SB6	126
7.15	Effective bearing area, tests TB-1 and SB-5	127

Figure		Page
7.16	Behavior of 90-degree bend	129
7.17	Post-tensioning test	130
7.18	Results of post-tension test	132

CHAPTER 1

INTRODUCTION

1.1 Background

Anchor bolt groups are commonly used in highway and bridge structures to connect light standards, sign supports, traffic signal poles, rails, and shoes to structural concrete members. Present AASHTO Specifications, however, provide the designer with little guidance regarding the proper use and design of such anchorage groups.

Limited studies indicate that the strength of several bolts in close proximity is adversely affected by the interaction between the bolts. While there may be a critical spacing beyond which the bolts behave individually, this spacing seems to be much larger than that which would normally be encountered in a typical highway structure. The strength of a bolt group cannot simply be defined on the basis of the sum of the strength of the single bolts. Before bolt group strength can be determined, research is needed to define the factors which affect the strength of a group. In particular, the interaction of edge cover, bolt spacing, end anchorage, and containment reinforcement must be investigated.

Previous studies [1,4,5] sponsored by the Texas State Department of Highways and Public Transportation identified factors affecting the strength and behavior of isolated anchor bolts. These investigations have focused on highway-related installations, which typically used long embedment length and relatively small edge cover. Such installations should be distinguished from bolts embedded for short lengths in mass concrete with very large cover. Short bolts exhibit failure mechanisms which are different from those of bolts embedded in mass concrete. A limited number of tests indicated that 90° bends were not as efficient as nut anchorages.

1.2 Strength of Isolated Anchor Bolts

Hasselwander, et al. [1] concluded that clear cover and bearing area were the main variables governing the strength of single anchor bolts. The variables were incorporated into an equation for predicting the strength of isolated anchor bolts, subjected to simple tension and failing in a wedge-splitting mode:

$$T_n \text{ (lbs)} = 140 A_b \sqrt{f'_c} \left[0.7 + k_n \left(\frac{2C}{D_w - D} \right) \right] \quad \text{Eq. 1}$$

where A_b is the net bearing area (in.²), D and D_w are the bolt and washer diameter (in.), C is the clear cover to the bolt (in.), and n is a natural logarithm. The design tensile strength, T_u , was determined as:

$$T_u \leq \phi A_{sm} f_y \leq \phi T_n$$

where

$$\begin{aligned} \phi &= \text{a capacity reduction factor of 0.75} \\ A_{sm} &= \text{mean tensile area of the anchor bolt} \\ f_y &= \text{yield stress of the bolt material} \end{aligned}$$

The design equation was developed from a regression analysis on test results of bolts failing in the wedge-splitting mode only. A minimum embedment length of $12(D_w - D)$ was suggested to allow the wedge-splitting mechanism to form (Fig. 1.1). A restriction which accounted for a reduced bearing efficiency observed for large washers, limited the bearing area to $4D^2$. Furthermore, a minimum washer thickness, $D_w/8$, was suggested to prevent excessive flexibility of the washer.

1.3 Behavior of Bolts in a Group

Limited test results reported by Hasselwander et al. [1] indicated that the interaction among bolts embedded in close proximity may result in an abrupt, nonductile failure of the bolt group at individual bolt loads significantly less than predicted for an isolated bolt with similar geometry. Three tests were conducted on two-bolt groups with 1 in. bolts on 5 in., 10 in., and 15 in. center-to-center spacing. All three groups had a clear cover of 2.5 in., an embedment length of $15D$, and an end anchorage consisting of a 1/2 in. thick nut and standard diameter (2.5 in.) washers.

In Fig. 1.2, the two-bolt groups and a single bolt with similar geometry are compared in terms of lead slip and average mean stress normalized with respect to $\sqrt{f'_c}$. On the average, the capacity of the bolts in a group was 51%, 65%, and 58% that of the single bolt for the 5 in., 10 in., and 15 in. spacing, respectively. The reduction in strength for the bolt groups was attributed to the interaction of splitting forces between the two bolts which did not allow the wedge-splitting mechanism to fully develop.

The ultimate strength of a bolt in a group is clearly not the same as that of an isolated bolt with similar geometry. Limited tests indicate that the critical spacing beyond which the bolts behave as single or isolated bolts is apparently much larger than spacings normally found in anchor bolt groups in highway structures.

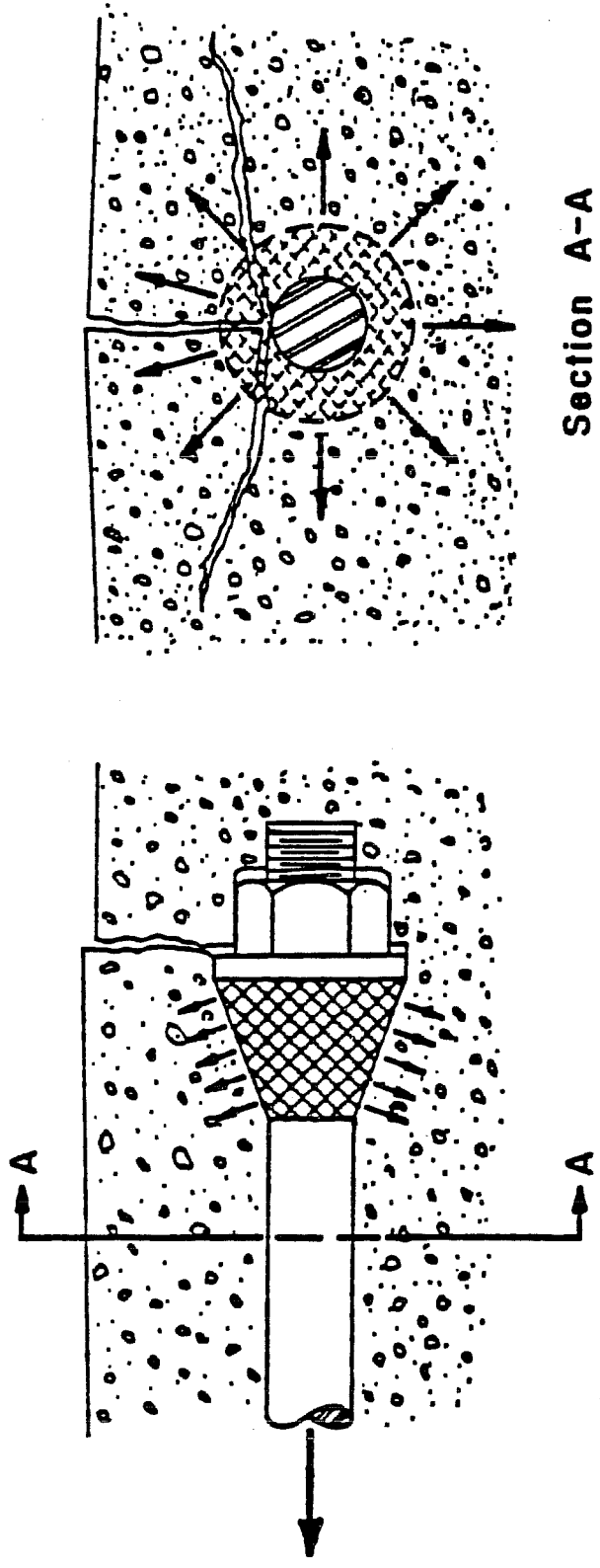

Section A-A

Fig. 1.1 Conditions around the anchorage after formation of the cone of crushed concrete

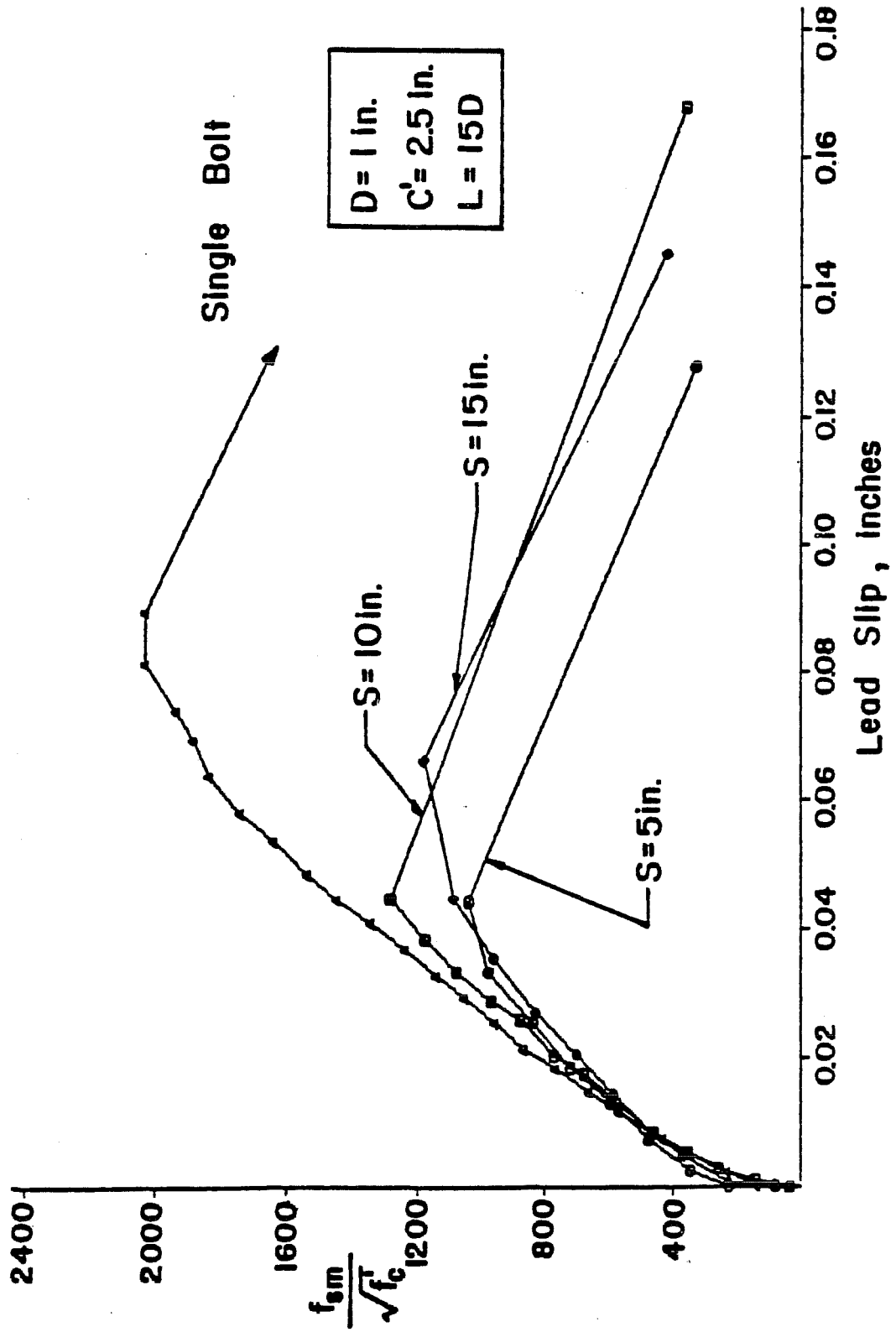

Fig. 1.2 Comparison of lead slip-lead stress curves of bolts in a group

1.4 Objective and Scope

In this study, the behavior and ultimate capacity of high-strength anchor bolts embedded in reinforced concrete piers was investigated. Two series of tests were conducted.

In the first series the effect of bolt spacing on group capacity was the main factor examined. In addition, the effect of (1) clear cover, (2) pier geometry, (3) variable anchorage lengths in a bolt group, (4) bearing area, and (5) transverse reinforcement were evaluated to a more limited extent. Anchor bolts with 1-3/4 in. diameter and 105 ksi yield stress were arranged in 2-, 3-, or 4-bolt groups and tested to failure in simple tension.

In the second series, single anchor bolts embedded in circular reinforced concrete piers were tested. The bolt arrangements are used in traffic signal or sign support foundations. Six bolts with three types of anchorages and two different strengths (55 and 105 ksi) were tested to failure. Anchorages consisted of 90° bends, 90° bends and straps, and nuts and straps. In addition, a typical two-bolt group used in overhead sign support foundations was first post-tensioned to determine losses and then tested to failure.

CHAPTER 2

SURVEY OF APPLICATIONS AND DESIGN DATA

2.1 Typical Anchor Bolt Applications and Design Data

Prior to developing a test program, it was necessary to determine how anchor bolt groups are used. A selected number of departments of highways and public transportation (California, Illinois, New York, Wyoming), in addition to Texas', were contacted to determine typical anchor bolt group applications and details. A review of the material obtained from these departments indicates that the use of anchor bolt groups for light standard supports, sign structure supports, traffic signal supports, and bridge shoe connections is fairly common in current practice.

A representative set of anchor bolt group applications and details is given in Figs. 2.1 through 2.8. It is interesting to note the various methods of anchoring bolts in the concrete; hooked ends (Figs. 2.6 and 2.7), nuts and washers (Figs. 2.2 and 2.3), threaded plate (Fig. 2.3), and nuts and washers with square (Fig. 2.4) or ring (Fig. 2.1) plates. It is also worth noting that some states use high-strength (typically $f_y = 75$ to 120 ksi) bolts, whereas other states use low-strength (typically $f_y = 36$ ksi) bolts.

Extensive use of anchor bolt groups is also found in massive concrete construction, such as in nuclear-related structures [2,3]. Generally, bolt groups with relatively short embedment lengths are used in mass concrete with very large edge covers. This is in contrast with highway-related installations which typically use long embedment lengths and relatively small edge covers. Different failure mechanisms can be expected in these cases. This study is limited to anchor bolt applications with relatively small edge cover along the entire length of the bolt and therefore is not directly applicable to the case of bolt groups embedded in mass concrete.

2.2 Literature Review--Design

Although the anchorage of structural members to concrete foundations is an almost universal design and construction requirement in highway and bridge structures, relatively little information exists documenting the behavior or suggesting design rules for anchor bolts. Most available information pertains to individual bolts. The following is a brief summary of anchor bolt literature:

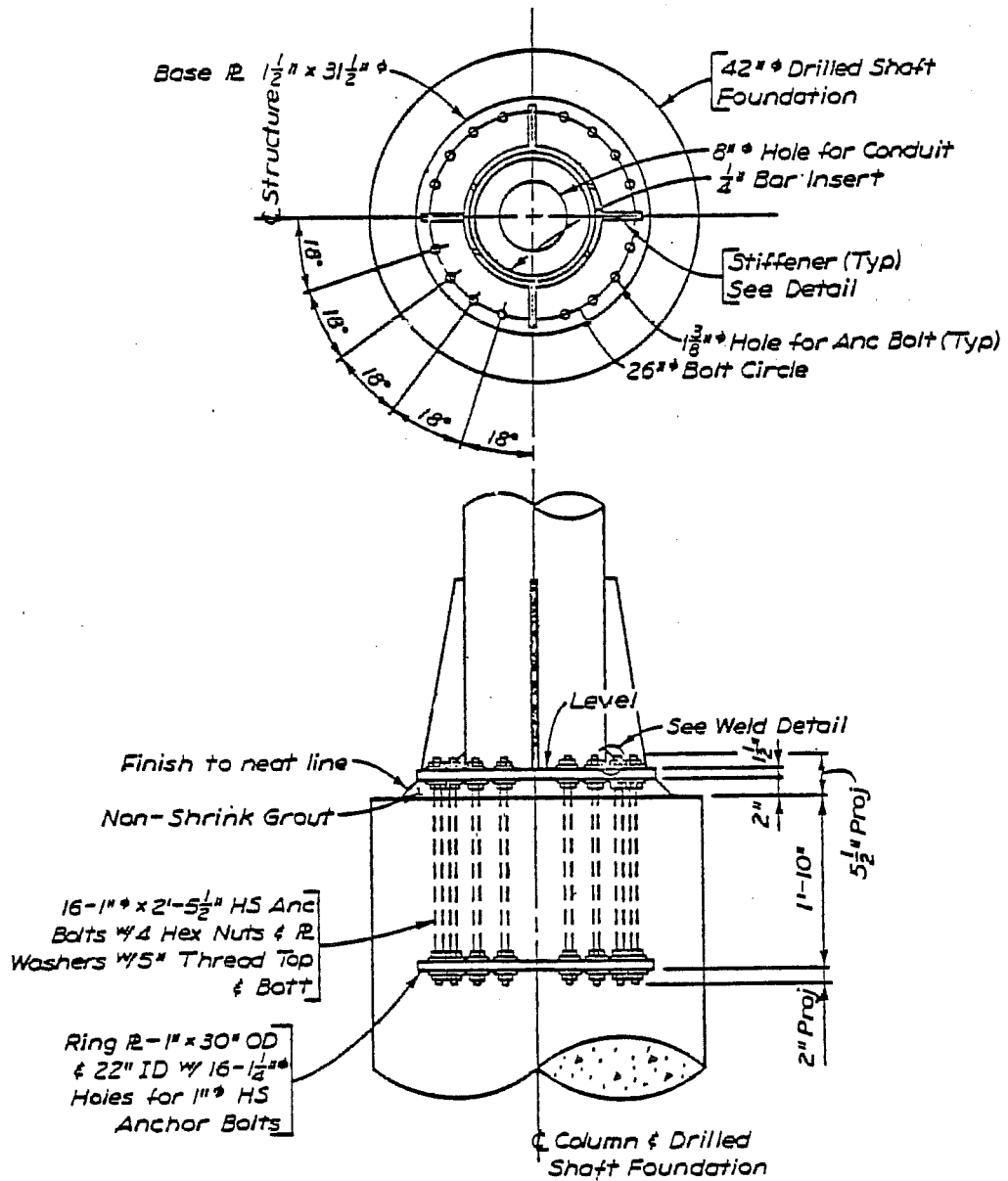

Fig. 2.1 Overhead sign support (Wyoming Highway Department)

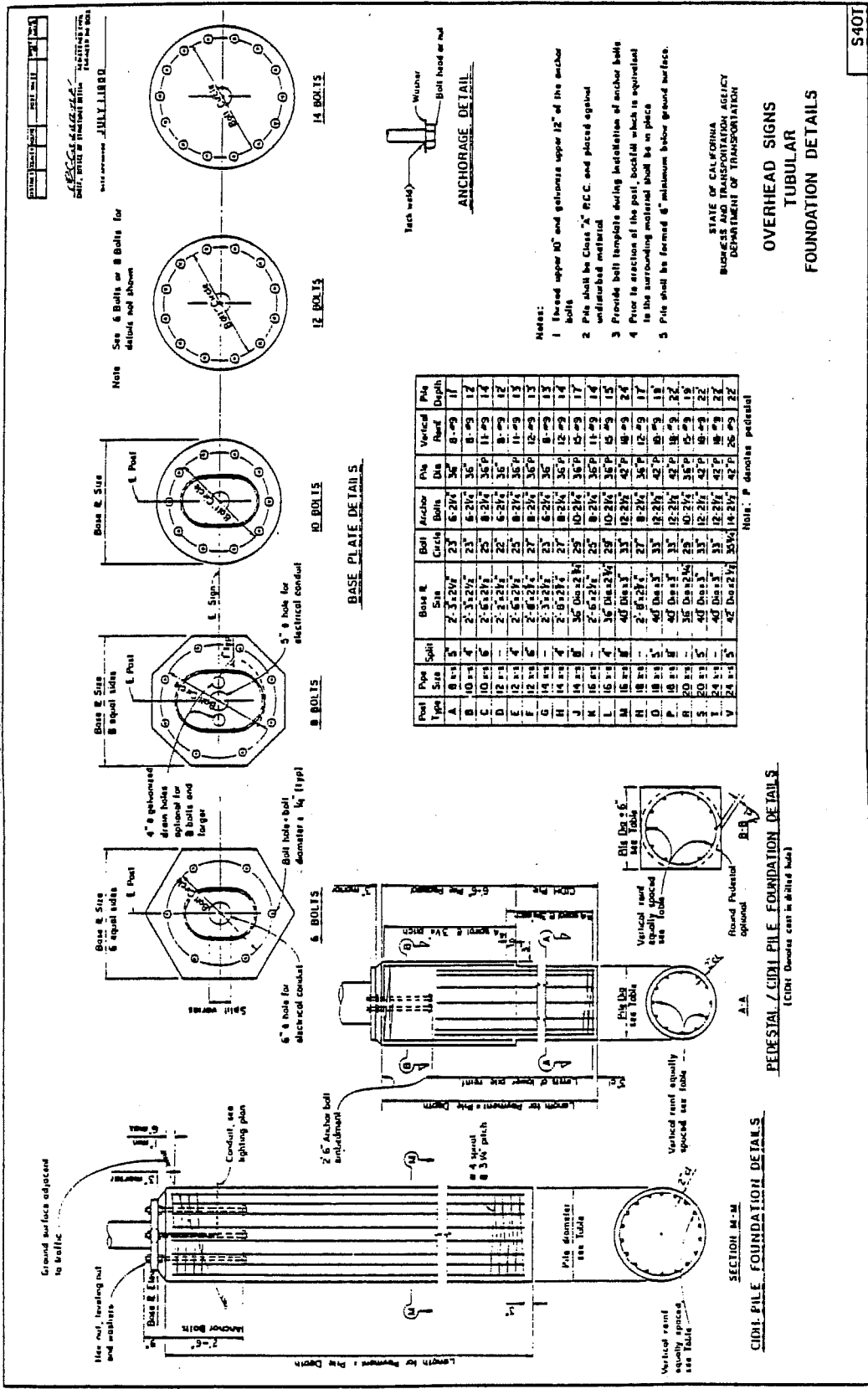

Fig. 2.2 Overhead sign support (California Department of Transportation)

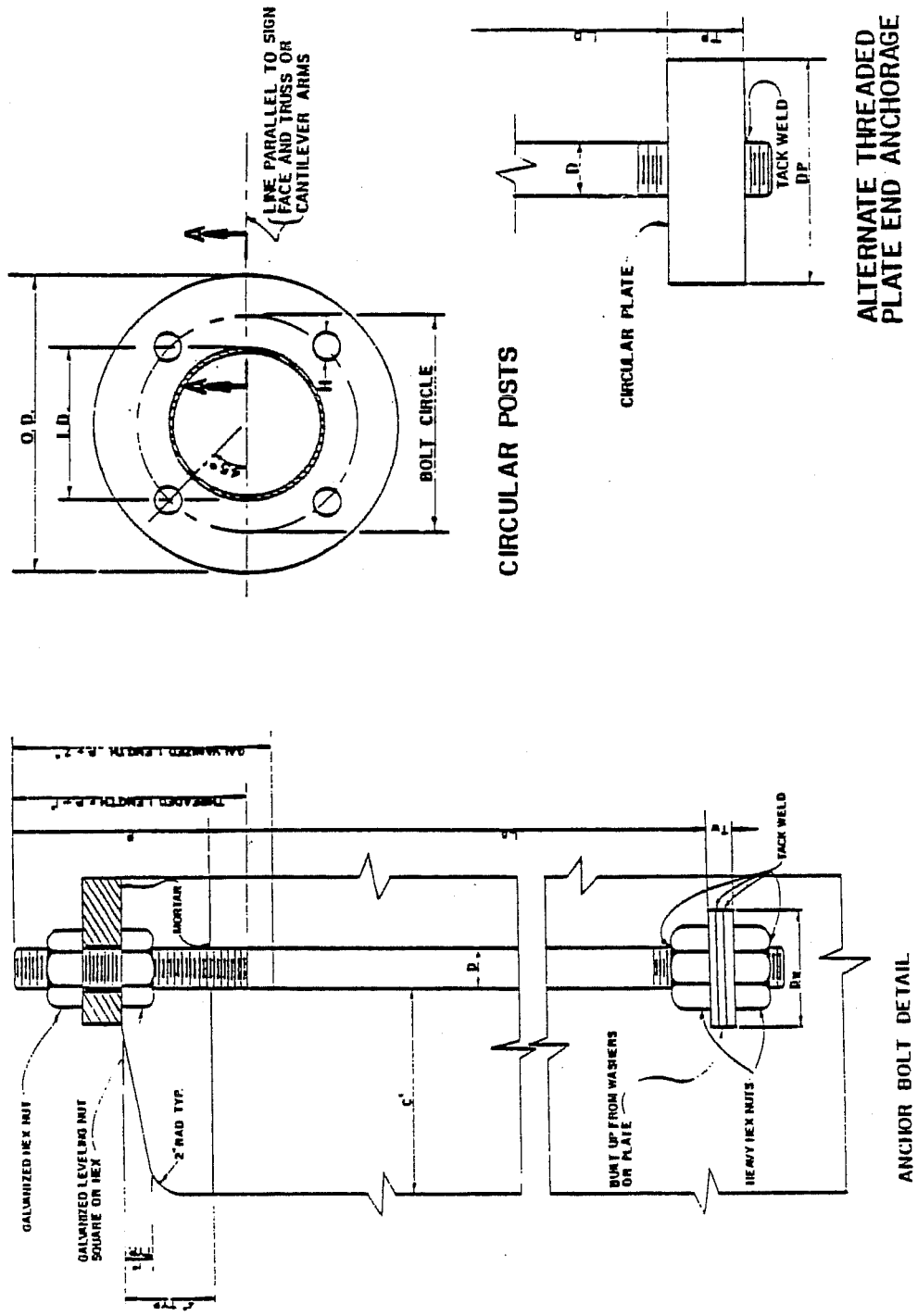

Fig. 2.3 Overhead sign support (New York Department of Transportation)

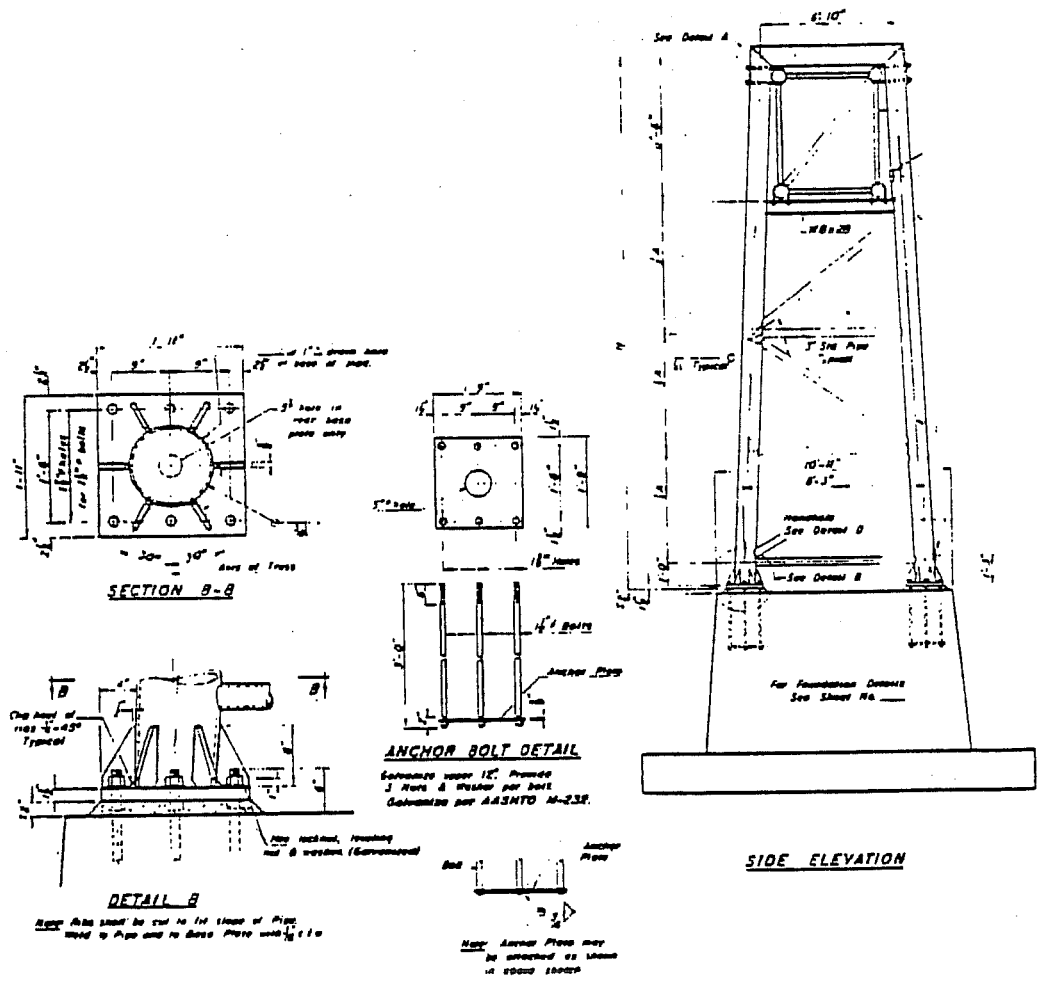

Fig. 2.4 Overhead sign support frame (Illinois Department of Transportation)

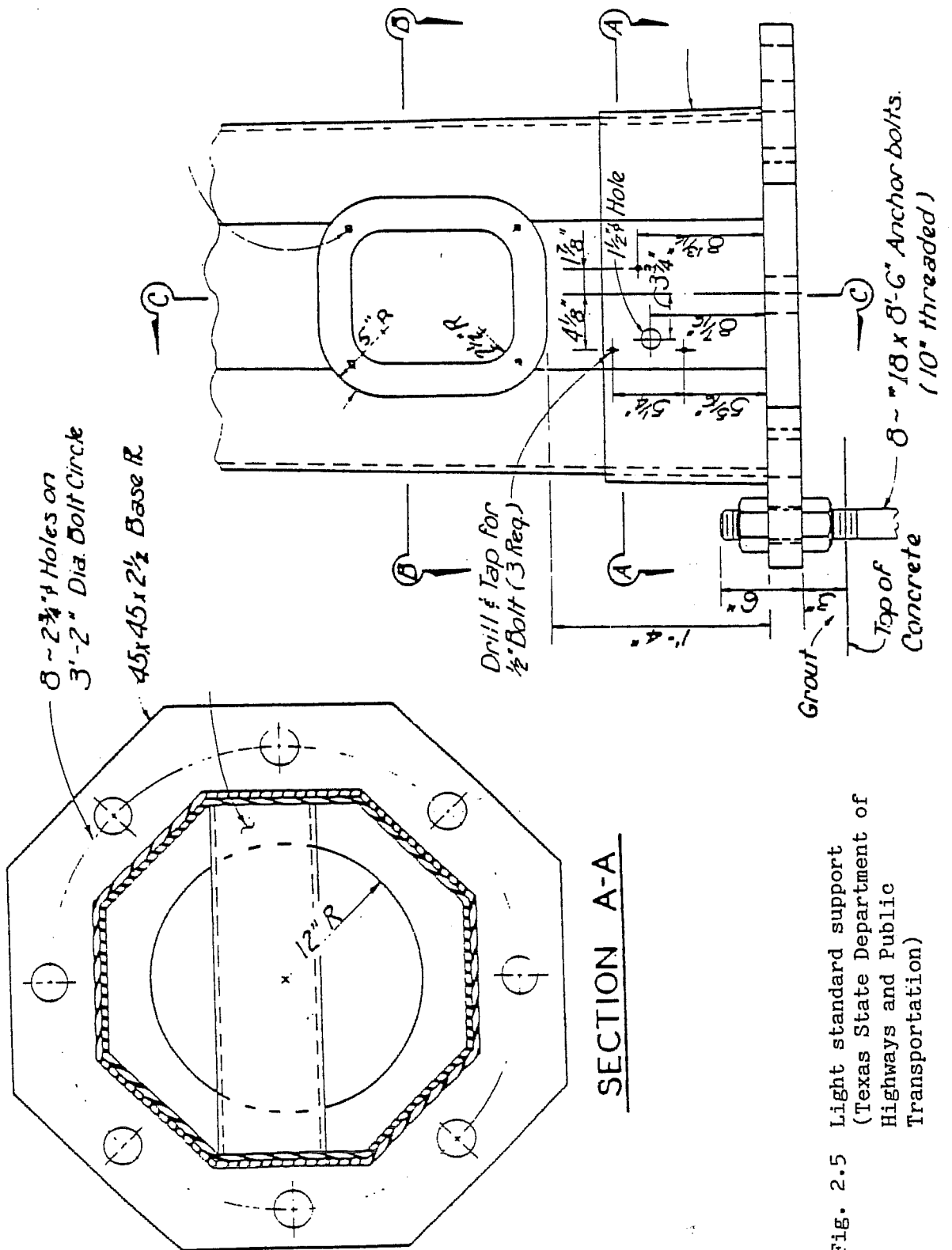

Fig. 2.5 Light standard support (Texas State Department of Highways and Public Transportation)

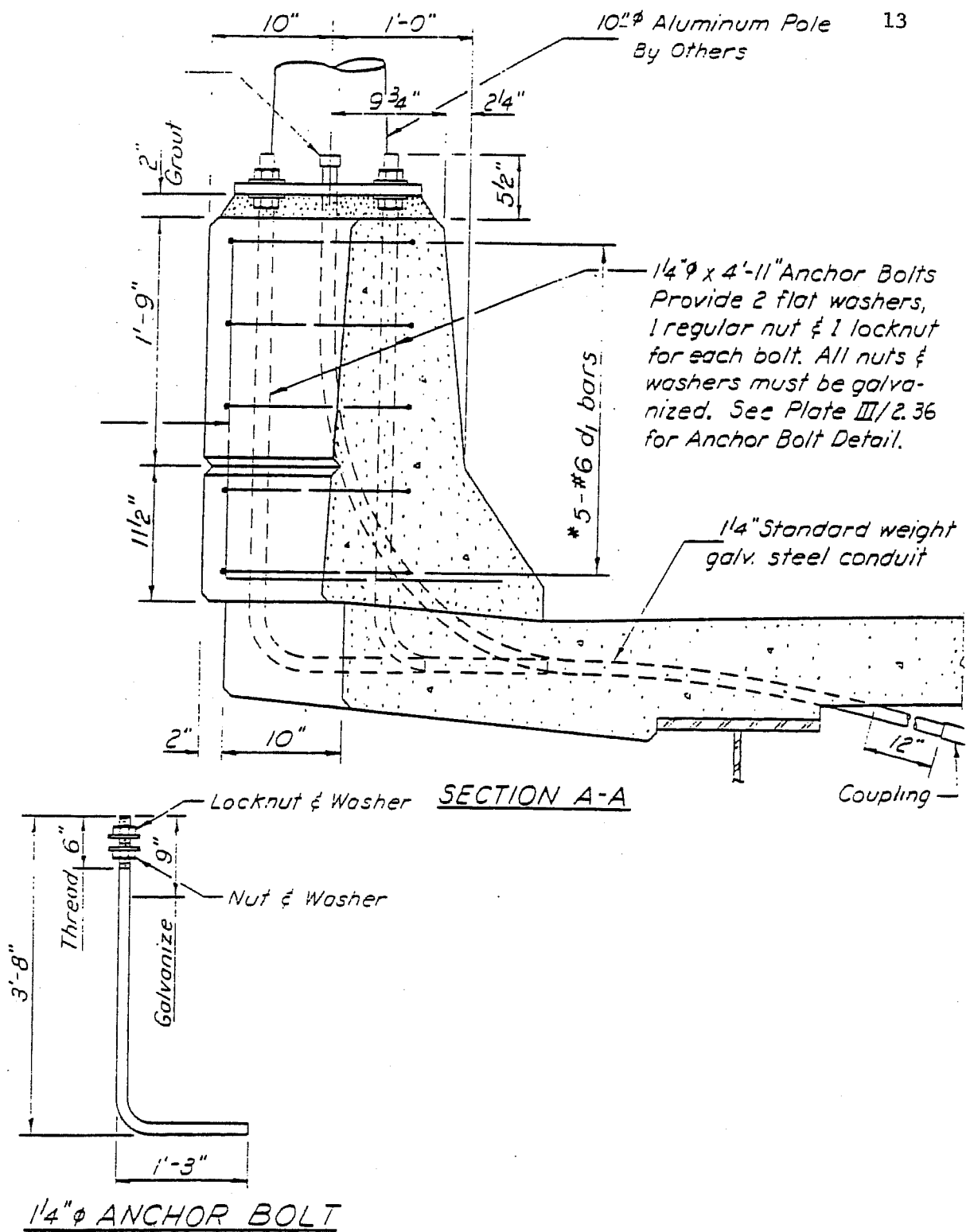

Fig. 2.6 Light standard support on concrete parapet (Illinois Department of Transportation)

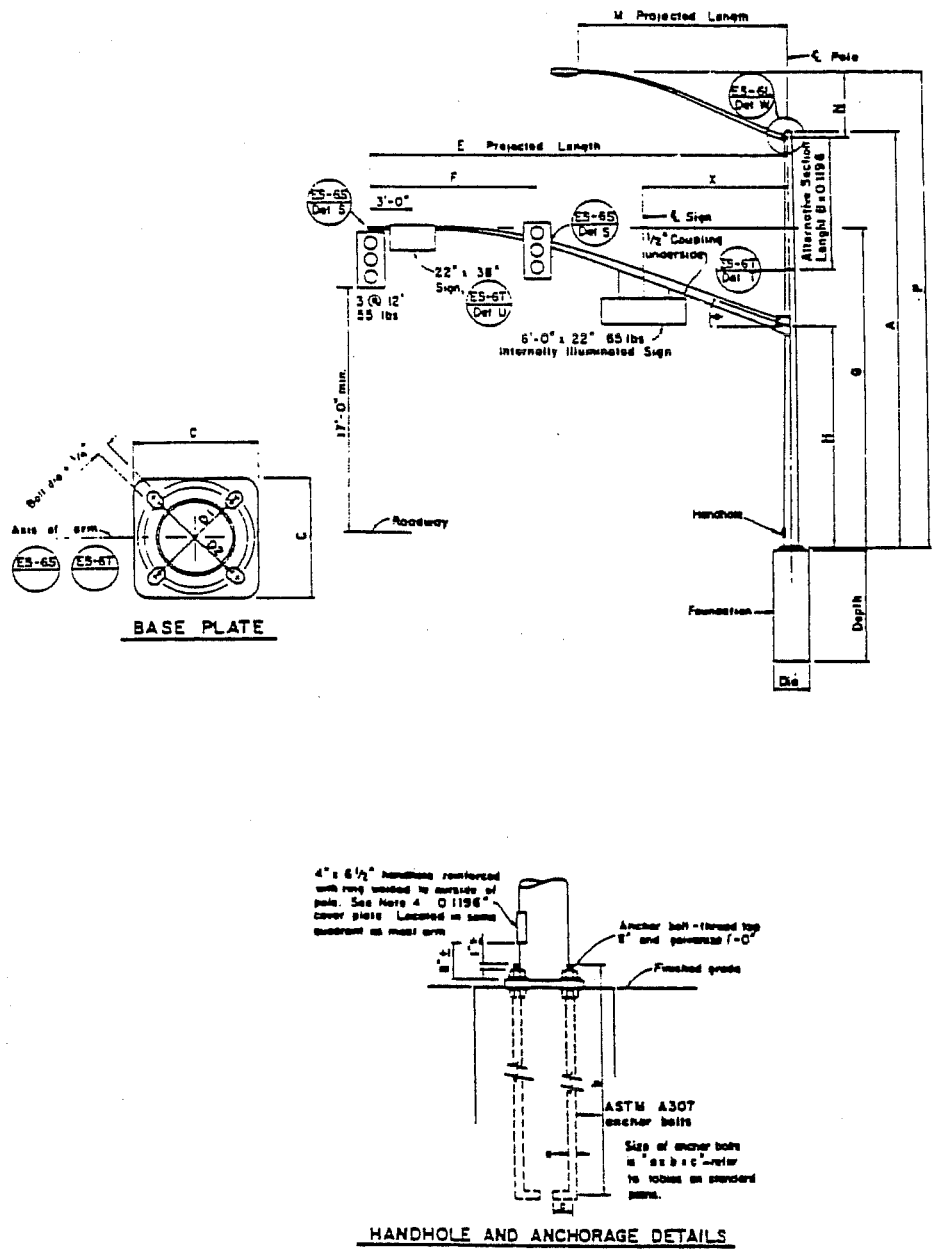

Fig. 2.7 Traffic signal and light standard support (California Department of Transportation)

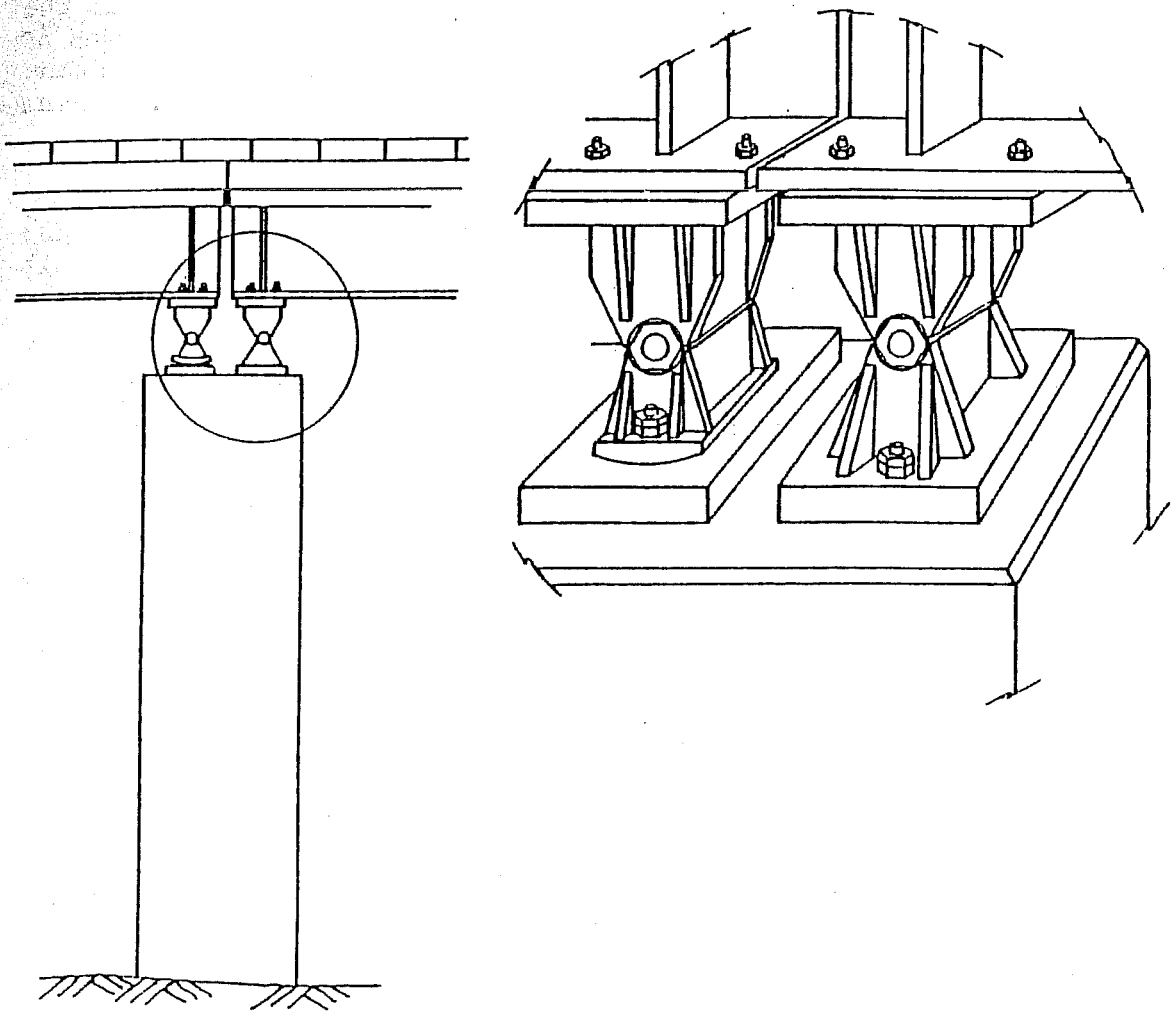

Fig. 2.8 Bridge bearing connection to pier cap
(California Department of Transportation)

University of Texas Center for Highway Research. The first two studies focused on typical drilled shaft footings supporting sign standards, while the third focused on concrete piers.

Development Length for Anchor Bolts [4]. In Project 3-5-63-55, anchor bolts of A7 (33 ksi yield stress) steel with diameters ranging from 1-1/4 in. to 3 in. diameter were tested. The end anchorage consisted of a nut or a nut with washer. The results indicated that all bolts could be developed with a 15D embedment length and for diameters less than 2 in., 10D was sufficient. Results also indicated that the most important factor in determining the bolt strength was the means of end anchorage. The amount of edge cover was shown to be an important variable, also. In addition, it was observed that very little stress was transferred by friction along the bolt.

Factors Affecting Anchor Bolt Development. [5] Project 3-5-65-88 was a continuation of Project 3-5-63-55. The objectives of the study were to investigate the following factors influencing anchor bolt development:

- (1) effect of clear cover
- (2) effect of low-cycle repeated loading
- (3) effect of circular shape of drilled shaft footing
- (4) effect of low concrete strength
- (5) effect of 90° bends as anchorage devices
- (6) effect of method of loading

In all the tests, 60 ksi yield bolts were used. Except for the 90° bent bolts, the bolts were anchored with a standard nut. The method of loading was altered to study the influence of lateral compressive forces in the vicinity of the anchor bolt.

The results indicated that the amount of slip was greatly reduced by the introduction of lateral compressive forces along the length of the bolt, but that the strength of the bolt was relatively unaffected. Again, as in Project 3-5-63-55, it was shown that concrete cover was a prime factor in the development of the bolt strength. Also, with lower concrete strength, the amount of slip was increased at comparable stress levels and anchor bolt strength was reduced. A limited number of tests using short 90° bends for end anchorage indicated that a hook was not as effective as a standard nut from the standpoint of slip resistance. Finally, low-cycle repeated loading and the shape of the footing (rectangular or circular) did not significantly influence the response.

Strength and Behavior of Anchor Bolts Embedded Near Edges of Concrete Piers [1]. The primary objectives of Project 3-5-74-29 were to evaluate the effects of bolt diameter, embedment length, clear cover, and bearing area on the behavior of high-strength anchor bolts. In addition, a series of exploratory tests were run to determine the influence of cyclic loading, lateral loading, bolt grouping, and

transverse reinforcement on the bolt behavior. Anchor bolts of up to 3 in. in diameter with yield strengths ranging from 50 to 130 ksi were used.

This study showed that the mechanism by which the bolt transfers load to the concrete is a sequence involving steel to concrete bond, bearing against the anchorage device, and, finally, wedging action by a cone of crushed and compacted concrete ahead of the anchorage device. Figure 1.1 showed the conditions around the anchorage device after the cone has formed. The test results indicated that clear cover and bearing area were the major variables influencing the strength of anchor bolts.

Results from the exploratory tests indicated that cyclic loads at or below service level did not negatively influence the strength or behavior of the anchor bolt. In addition, transverse reinforcement (in the form of hairpins along the bolt in front of the anchorage device) significantly increased the strength of anchor bolts with relatively shallow cover. Also, results indicated that the presence of lateral load applied in addition to the bolt tension influenced both the failure mode (bolt yielding, cover spalling, or wedge splitting) and the amount of top cover that was damaged by the lateral deformation of the bolt. It was concluded that the application of lateral force normal to the specimen resulted in a significant reduction in the ultimate tensile strength as well as the stiffness of the anchor bolt installation. In fact, a relatively low level of lateral shear reduced the pullout strength of the bolt by almost 50%.

As mentioned in Sec. 1.3, a limited exploratory study on the effect of anchor bolt groups established that there was substantial interaction between the bolts in the groups. It is interesting to note that the single bolts failed with considerable cracking prior to failure, while all of the bolt groups failed very abruptly with little previous cracking. This led to the conclusion that bolts in a group may exhibit sudden, brittle failure modes at loads corresponding to individual bolt loads significantly less than the strength of a single bolt with similar geometry.

California Department of Transportation, Lateral Resistance of Anchor Bolts Installed in Concrete [6]. This study focused on typical bridge superstructure to substructure connections using anchor bolts. Significant parameters investigated were:

- (1) edge distance
- (2) bolt strength
- (3) type of reinforcement
- (4) bolt diameter
- (5) method of loading
- (6) number of bolts

Both 1 in. and 2 in. diameter anchor bolts were used, with all bolts having an embedment length of 10D. There were 92 individual tests performed, 78 in pure shear and 14 in combined shear and bending. Ten of these tests were subjected to low-cycle loading. Fourteen of the pure shear tests were conducted on pairs of 1 in. diameter bolts to determine the effect of group action.

From the tests performed it was determined that approximately 8 in. of edge distance is required to develop the ultimate shear strength of a 1 in. diameter anchor bolt, while 24 in. would be required for a 2 in. bolt. Results also indicate that the use of hairpin reinforcement substantially increases system ductility and ultimate load capacity regardless of bolt diameter or edge distance. Combined loading produced significantly greater deflections at a given shear stress level, while low-cycle loadings had a negligible effect on the lateral resistance. It is also interesting to note that the use of a high-strength bolt had little effect on the lateral resistance.

Results from the tests on bolt pairs are shown in Fig. 2.9. The curves for the bolt pair tests are drawn to one-half vertical scale so that the ordinate represents the applied load per bolt. As can be seen from this figure, there are significant reductions (approximately 15 to 30%) in per-bolt load-carrying capacity with reduction in spacing between bolts. Although the group action test data were limited, the report noted that the combined load resistance of an anchor bolt pair is less than the sum of the individual bolt capacities if the spacing perpendicular to the loading direction is less than approximately four times the minimum edge distance.

Tennessee Valley Authority, Anchorage to Concrete [2]. The study focused on typical applications found in nuclear power plant construction. As mentioned previously, anchor bolt installation in nuclear-related structures generally do not typify anchor bolt installations in highway-related structures. However, this study does give some relative information on the general behavior of individual anchor bolts as well as bolt groups.

The program was divided into three phases: determination of embedment requirements for various anchorage systems by means of tensile pullout tests, determination of shear strength for the more efficient tensile anchorage systems, and the effect of combined tension and shear on the various systems. One of the anchorage systems investigated was cast-in-place anchor bolts. Shear tests on the individual bolts were directed at establishing restrictions for edge loaded bolts. The tests were not fully successful because the hairpin reinforcement which was installed to prevent concrete wedge failures was fabricated from plain bars instead of deformed bars and bond failures occurred. Even so, the report concluded that the shear strength of bolts should be reduced for edge-loaded bolts located closer than 1-1/4 times the required embedment of the bolt. In addition, shear test on four-bolt groups established

ANCHOR BOLT PAIRS

Diameter. : 1"
 Type of steel. : Mild
 Edge distance. : 6"
 Method of installation. : Cast-in-place
 CONCRETE REINFORCING. : Nominal
 TYPE OF LOADING. : Shear
 SPACING BETWEEN BOLTS : Varies

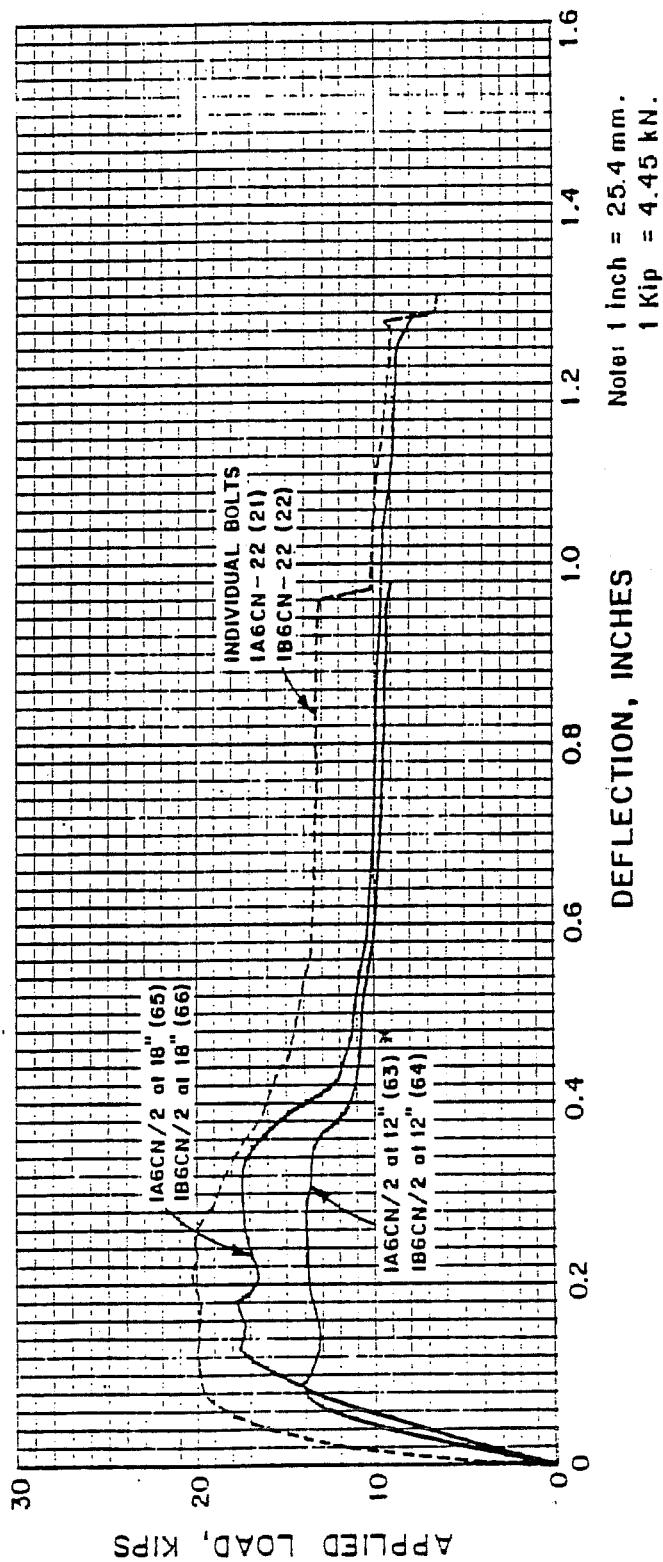

Fig. 2.9 Effect of bolt spacing on the lateral resistance of anchor bolt pairs (Ref. 6)

the importance of the method of attachment on the shear strength of bolt groups.

Two interesting observations were made from the results of the tensile phase of this study; namely,

(1) When the bolts were spaced close enough for an intersection of the pullout cones to occur, the concrete failure plane was always a straight line between the bolt heads. This implies that the tensile strength of the concrete between the bolts is a major factor in determining anchorage requirements.

(2) Tensile tests with 2 in. edge distance for the 3/4 in. bolts and 4-1/2 in. edge distance for the 1 in. high-strength bolts clearly indicated that a minimum side cover dimension is required to fully restrain the side pressure resulting from bearing load transfer at the head of the bolt. In fact, a complete side cone "blowout" occurred with the 19 in. embedment of the A490 bolts. It was concluded that for deep embedments the apparent side thrust is approximately 1/4 of the bolt tensile capacity.

It is worth noting that in the tensile tests the bolts were embedded in unreinforced concrete.

Results of this study can be found in ACI 349-76, "Code Requirements for Nuclear Safety Related Concrete Structures." [3] Of particular interest is the section on tension design requirements for concrete, which states:

The pullout strength of concrete for any anchorage shall be based on a uniform tensile stress of $4\phi\sqrt{f'_c}$ acting on an effective stress area which is defined by the projected area of stress cones radiating toward the attachment from the bearing edge of the anchors. The effective area is limited by overlapping stress cones, by the intersection of the cones with concrete surfaces, by the bearing area of anchor heads, and by the overall thickness of the concrete. The inclination angle for calculating projected areas shall be 45° . The ϕ factor shall be taken as 0.65 for an embedded anchor head....

This design concept is illustrated in Fig. 2.10. Note the concrete cone pullout failure, characteristic of this type of installation.

Finally, various procedures for predicting the nominal tensile and shear capacity of "short" anchor bolts, that is, one having an embedment length insufficient to develop tensile yield in the bolt without providing end anchorage, are summarized in Refs. 7 and 8.

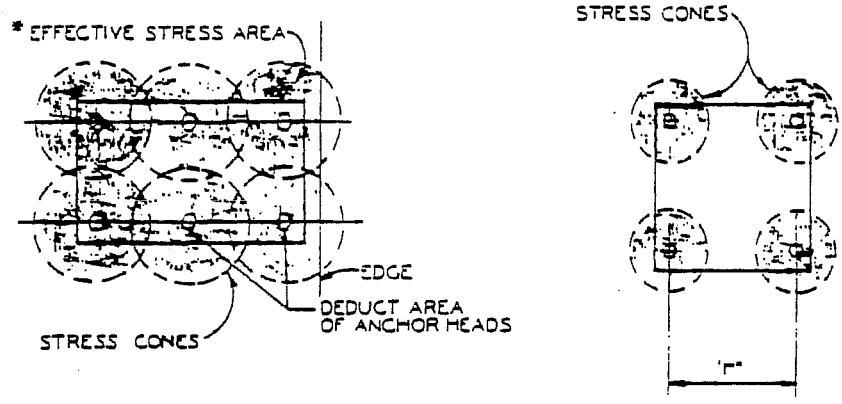

*REDUCE BY THE TOTAL BEARING AREA OF THE ANCHOR STEEL.

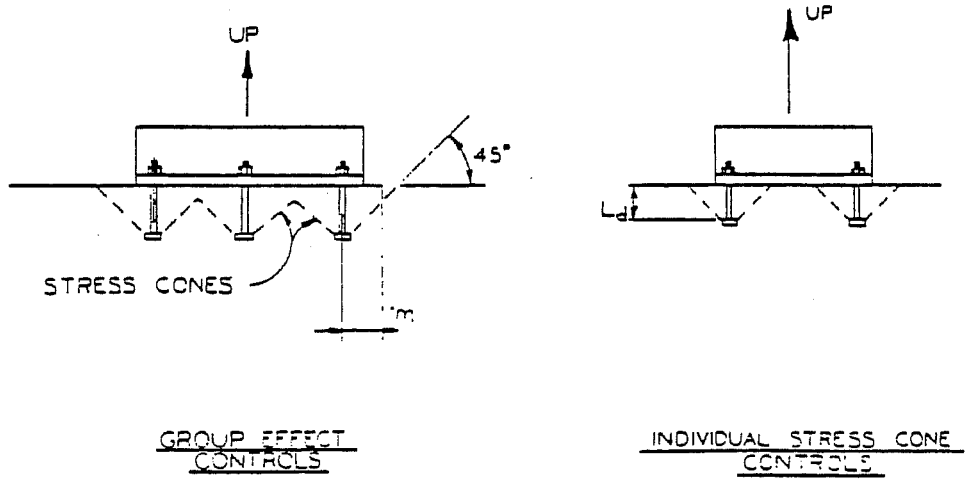
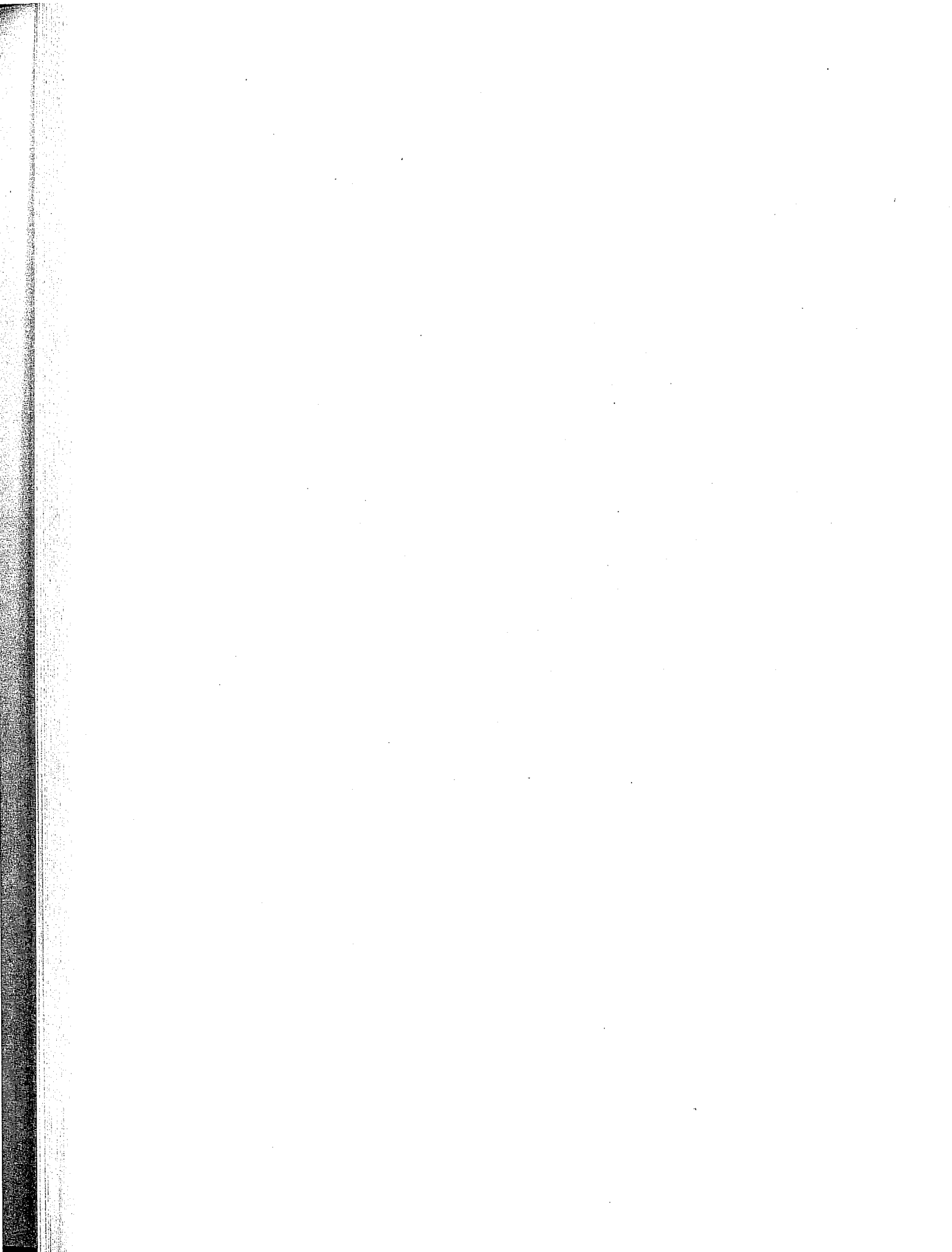

Fig. 2.10 Effective stress area for anchorage pullout (Ref. 3)



CHAPTER 3

EXPERIMENTAL PROGRAM - BOLT GROUPS

3.1 Introduction

Drawings representing various anchor bolt group applications were obtained from the Bridge Division of the Texas State Department of Highways and Public Transportation (SDHPT). A cantilever overhead sign support base was chosen as the prototype for the study. The details of prototype installations used in the development of the specimen are described in Fig. 3.1 and Table 3.1. The specimen represents a reinforced concrete drilled shaft footing with cast-in-place anchor bolts. The bolts are used to anchor the overhead sign structure to the footing. Typical details call for six equally spaced, high-strength ($f_y = 105$ ksi) anchor bolts arranged in a circular pattern for the base connection. The prototype bolt pattern was modified to accommodate eight bolts (four in tension) in designing the test specimen (see Fig. 3.2).

The design procedure used by the SDHPT for this connection is governed by the size of tower pipe required. When computing design loads, the neutral axis in bending is assumed at the centroid of the bolt group. Bolts are typically embedded to a length of twenty bolt diameters (20D). The design stress at service (unfactored) load level is limited to 55 ksi for high-strength bolts because of fatigue considerations. No reduction factor for the group capacity is used to account for bolt interaction.

For test purposes, the applied moment is oriented to yield the lowest capacity from the eight bolt connection. Under this condition, there is a pair of bolts equally spaced from the bending axis as shown in Fig. 3.2.

In the first 10 tests [9,10], bolts were arranged in four-bolt semicircular groups, as shown in Fig. 3.2. The upper level bolts were stressed higher than the lower level bolts. From observations of lower bolt behavior, it was concluded that only the top two bolts failed with minor interaction from the lower level bolts. Therefore, in the next 9 tests, two-bolt groups [11] were used. The two major advantages of this arrangement were that (1) the range of variables investigated could be broadened without having to modify the existing test setup, and (2) three individual tests could be performed on each specimen with better efficiency of material and labor. Only two tests per specimen could be performed with the four-bolt groups. Thus, the two-bolt arrangement provided a practical and efficient way to obtain additional data for the development of design recommendations. Also, to ensure consistency of test results between the two-bolt and four-bolt groups, one test (TB3)

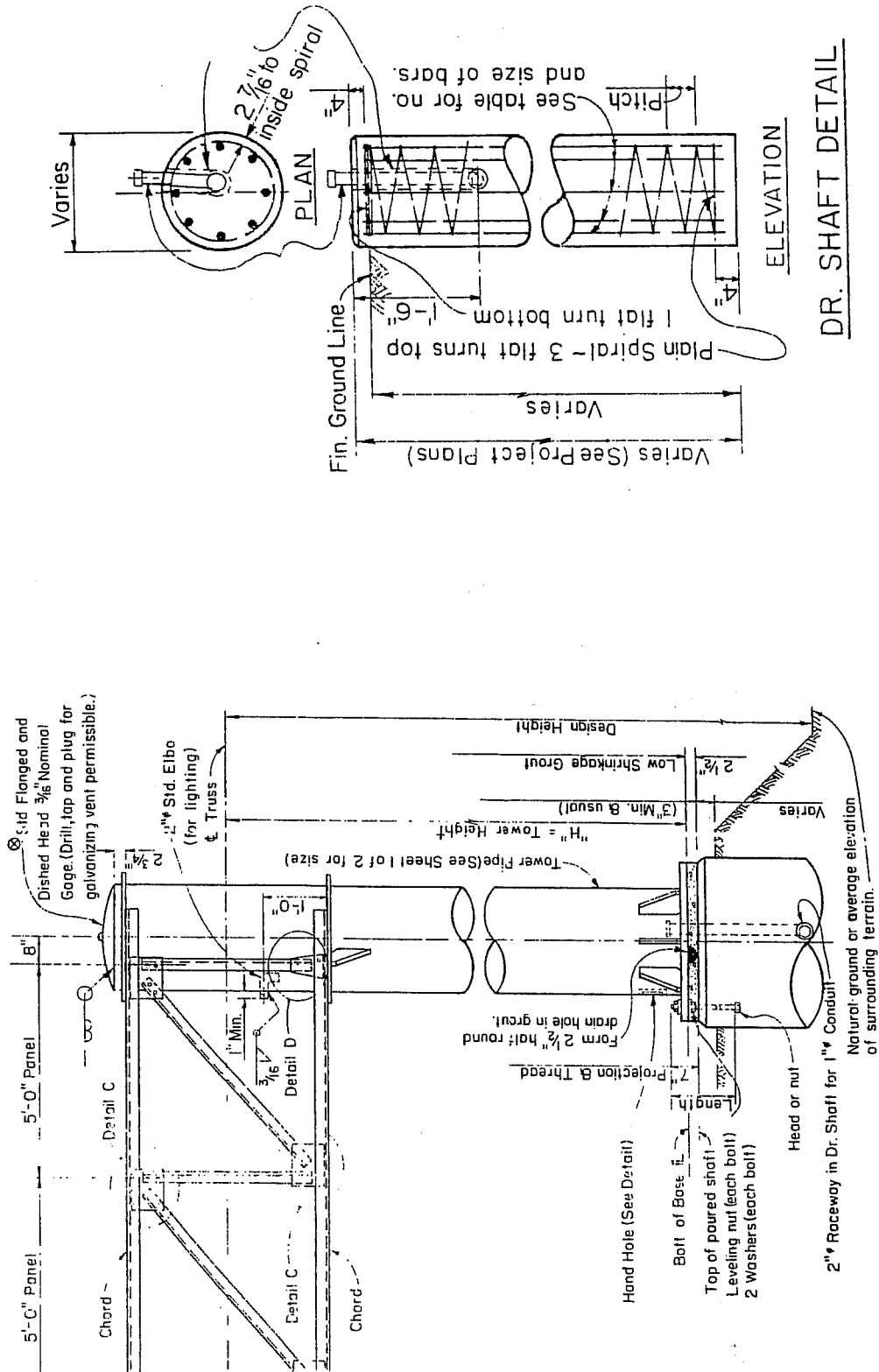

Note: See Table 2.1 for bolt group arrangement

Fig. 3.1 SDHPT details - cantilever overhead sign support base

Table 3.1 SDHPT standard plans--cantilever overhead sign support structure

PIPE OUTSIDE DIAMETER												
16"			20"			24"			30"			
ANCHOR BOLT SIZE	BOLT CIRCLE DIA.	DR. SHAFT SIZE	DR. SHAFT REINF.	BOLT CIRCLE DIA.	DR. SHAFT SIZE	DR. SHAFT REINF.	BOLT CIRCLE DIA.	DR. SHAFT SIZE	DR. SHAFT REINF.	BOLT CIRCLE DIA.	DR. SHAFT SIZE	DR. SHAFT REINF.
1/4" X 2'-8"	20 1/2"	36"φ	8-#10(A)	24 1/2"	36"φ	8-#10(A)						
3/8" X 2'-11"	20 3/4"	36"φ	8-#10(A)	24 3/4"	36"φ	8-#10(A)						
1/2" X 3'-1"	21"	36"φ	8-#10(A)	25"	36"φ	8-#10(A)	29"	42"φ	12-#10(A)			
1 1/2" X 3'-1"							29"	48"φ	12-#11(A)			
3/4" X 3'-6"	21 1/2"	36"φ	8-#10(A)	25 3/8"	36"φ	8-#11(B)	29 3/8"	42"φ	12-#10(B)	35 3/8"	48"φ	12-#11(B)
1 3/4" X 3'-6"				25 3/8"	42"φ	12-#10(A)	29 3/8"	48"φ	12-#11(A)	35 3/8"	54"φ	18-#10(A)
2" X 3'-11"	22"	36"φ	8-#10(A)	25 3/4"	42"φ	12-#10(A)	29 3/4"	42"φ	12-#10(C)	35 3/4"	48"φ	12-#11(C)
2 1/4" X 3'-11"	22"	42"φ	12-#10(A)	25 3/4"	48"φ	12-#11(A)	29 3/4"	48"φ	12-#11(A)	35 3/4"	54"φ	18-#10(A)
2 1/4" X 4'-4"				26"	42"φ	12-#10(A)	30"	42"φ	15-#10(C)	36"	48"φ	16-#11(C)
2 1/4" X 4'-4"				26"	48"φ	12-#11(A)	30"	48"φ	12-#11(A)	36"	54"φ	18-#10(C)
2 1/2" X 4'-9"							30 1/2"	42"φ	15-#10(C)	36 1/2"	48"φ	20-#11(C)
2 1/2" X 4'-9"							30 1/2"	48"φ	12-#11(A)	36 1/2"	54"φ	18-#10(C)

A = # 3 Plain Spiral at 6" pitch. (Grade 40) C = # 4 Plain Spiral at 6" pitch. (Grade 60)
 B = # 4 Plain Spiral at 6" pitch. (Grade 40) D = # 4 Plain Spiral at 3 1/2" pitch. (Grade 60)

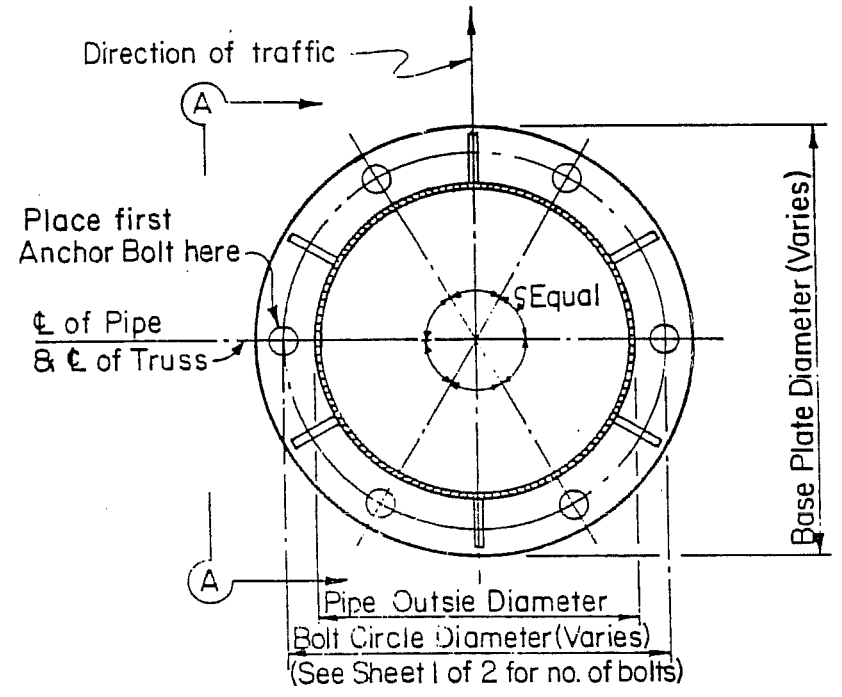

(a) Prototype

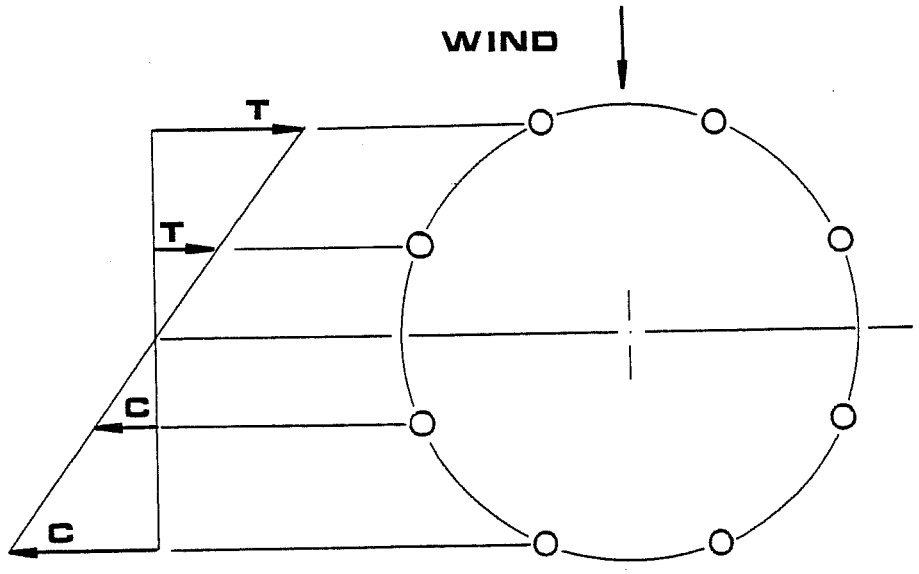

(b) Test pattern

Fig. 3.2 Orientation of loading on bolt group in circular pier

in the two-bolt series duplicated the nominal clear cover and bolt spacing used in one of the four-bolt tests (SC8).

Finally, to determine the influence of pier geometry or group strength, four groups of three-bolt embedded square specimens were tested [12]. The three-bolt group provided a test where the center bolt represents a typical interior bolt in a group.

3.2 Description of Tests

The 23 bolt-group tests are summarized in Table 3.2. Bolt diameters were 1-3/4 in. in all tests. ASTM A193, Grade B7 alloy was used for all bolts ($f_y = 105$ ksi). Bolt spacing and clear cover were the major variables considered in the test program. Clear cover and bolt spacing represent the values typical of highway applications. "Clear cover" is the clear distance between a bolt and the concrete surface along a line normal to the surface. In the test program, values from 2.4 to 7.4 in. were used. "Bolt spacing" is the center-to-center distance between adjacent bolts and varied between 4 and 13.5 in.

The anchorage consisted of a nut and either 2 or 3 washers in all but one test. In NOW (no washers), only a nut was placed at the embedded end of the bolts. The anchorage length for all tests except STG1 and STG2 was 20D or 35 in.

Staggered bolts in tests STG1 and STG2 were used to offset the interaction of the failure surfaces. Staggering consisted of moving adjacent bolts 5 in. above and below the standard 35 in. embedded length. On the average, the group embedment was not changed and those bolts with a short embedment (30 in.) still satisfied the minimum embedment, 15D, recommended in previous studies [2,4]. The two tests were aimed toward finding a practical method, other than increasing the bolt spacing, to separate the cones of crushed and compacted concrete at the front of the anchorage device. The staggered bolts were tested with two significantly different cover conditions.

In many tests, the role of transverse reinforcement on bolt group behavior was studied by instrumenting the spiral cage or hoops where the spiral bar crosses the most highly stressed bolts. The increase in the tensile force in the spiral with increase in the bolt force provided data regarding the formation of the wedge failure mechanism.

3.2.1 Four-Bolt Groups. The geometry and details of the 10 tests with four-bolt groups are shown in Fig. 3.3. For 36 and 42 in. drilled shafts, typical designs include 8 to 16 longitudinal bars (#10 or #11) and #3 or #4 plain bar spirals at 6 in. pitch. For the test specimens, sixteen #11 bars were used for the first two tests, and eight #11 plus eight #9 bars were used in the fabrication of the last three specimens. The smaller bars were placed in pairs at 45 degrees with the horizontal

Table 3.2 Description of tests

Test	Drilled Shaft Dia. (in.)	Bolt Spacing ¹ (in.)	Clear Cover ² (in.)	Anchorage Type ³	f'_c (psi)	Age (days)
<u>4-Bolt Groups</u>						
SC1	36	11.4	2.7	2WN	3500	65
SC2 ⁴	36	9.1	5.7	2WN	3600	90
SC3	42	12.0	4.0	2WN	4100	71
SC4	42	11.0	5.6	2WN	4200	82
NOW	36	10.0	4.7	NOW	3900	87
SC6	36	10.0	4.5	2WN	3900	122
SC7	42	13.5	2.4	2WN	3600	79
SC8	42	9.3	7.8	2WN	3600	87
STG1	36	11.2	2.4	2WN-STG	3800	25
STG2	36	8.9	5.4	2WN-STG	3900	43
<u>2-Bolt Groups</u>						
TB1	42	9.2	4.2	2WN	3400	39
TB2 ⁴	42	---	---	2WN	3450	57
TB3	42	9.9	6.4	2WN	3500	72
TB4	42	9.0	2.8	3WN	4600	98
TB5	42	6.0	4.0	3WN	4650	102
TB6	42	13.5	4.9	3WN	4700	107
TB7	42	6.2	2.7	3WN	4150	27
TB8	42	4.0	3.7	3WN	4200	34
TB9	42	6.0	7.3	3WN	4250	39
<u>3-Bolt Groups</u>						
3B-1	42-sq	4.0	4.0	3WN	3550	21
3B-2	42-sq	6.0	4.0	3WN	3550	25
3B-3	42-sq	8.9	4.0	3WN	3650	36
3B-4	42-sq	13.5	4.0	3WN	3650	41
3B-5	42-sq	one-bolt	4.0	3WN	3650	42

¹ Center-to-center distance between bolts.

² Distance between edge of bolt and concrete surface.

³ 2WN: 2 std. washers and a nut; 3WN: 3 std. washers and a nut;

NOW: no washers; STG: staggered bolts.

⁴ Test omitted from study due to damage prior to testing or difficulty with data acquisition.

bolt group axis. The specimens were overreinforced, compared with the prototype, to ensure that the bolt group failed prior to flexural failure of the pier or anchorage failure of the rebars.

The bolts in a typical specimen were embedded into the concrete about 37 in., which includes 2 in. for the nut and washers. Previous research [5] indicates that a single standard-diameter washer may not be fully effective in bearing. To prevent excessive bending in the washers, a minimum thickness $D_w/8$ (D_w = washer diameter) has been suggested. To approximate this requirement for the 1-3/4 in. bolts, two 3/16 in. washers ($D_w = 4.0$ in.) were specified, along with a nut as the anchorage device. One bolt group in specimen 3 (test NOW) was cast without washers. Bolts in specimen 5 were staggered, as shown in Fig. 3.3(b). The group average embedment length (35 in.) is equal to that in all other tests.

The overall concrete specimen length, 6.5 ft, was chosen to eliminate interference from the reaction supports on the anchorage region. In addition, the layout of the test frame and the floor reaction system also dictated certain constraints on the specimen length.

3.2.2 Two-Bolt Groups. Nine tests of two-bolt groups were performed using three 42 in. piers. Table 3.2 provides a description of test variables. The dimensions and reinforcement details for the specimens were as shown in Fig. 3.3.

Figure 3.4 shows the placement of the two-bolt groups in the pier. End anchorage in specimens TB1, TB2, and TB3 consisted of two standard washers (3/16 in. thick). However, excessive bending in the washers in the four-bolt groups indicated that two washers may not be sufficient. Therefore, three washers were specified for the remaining two-bolt groups.

3.2.3 Three-Bolt Groups. Two square piers were constructed with two three-bolt groups in each specimen. General dimensions and arrangement of reinforcement are illustrated in Fig. 3.5. The bolt diameter, embedment length, and pier size were chosen to maintain consistency with the previous series of tests. Transverse reinforcement consisted of #4 ties spaced at 6 in. intervals. Placement of longitudinal bars relative to the anchor bolts was consistent with the previous tests in which the same clear cover and spacing were used.

3.3 Materials

In general, selection of materials conformed to the standard specifications [13] of the SDHPT. The Specifications also served as a reference guide for the construction.

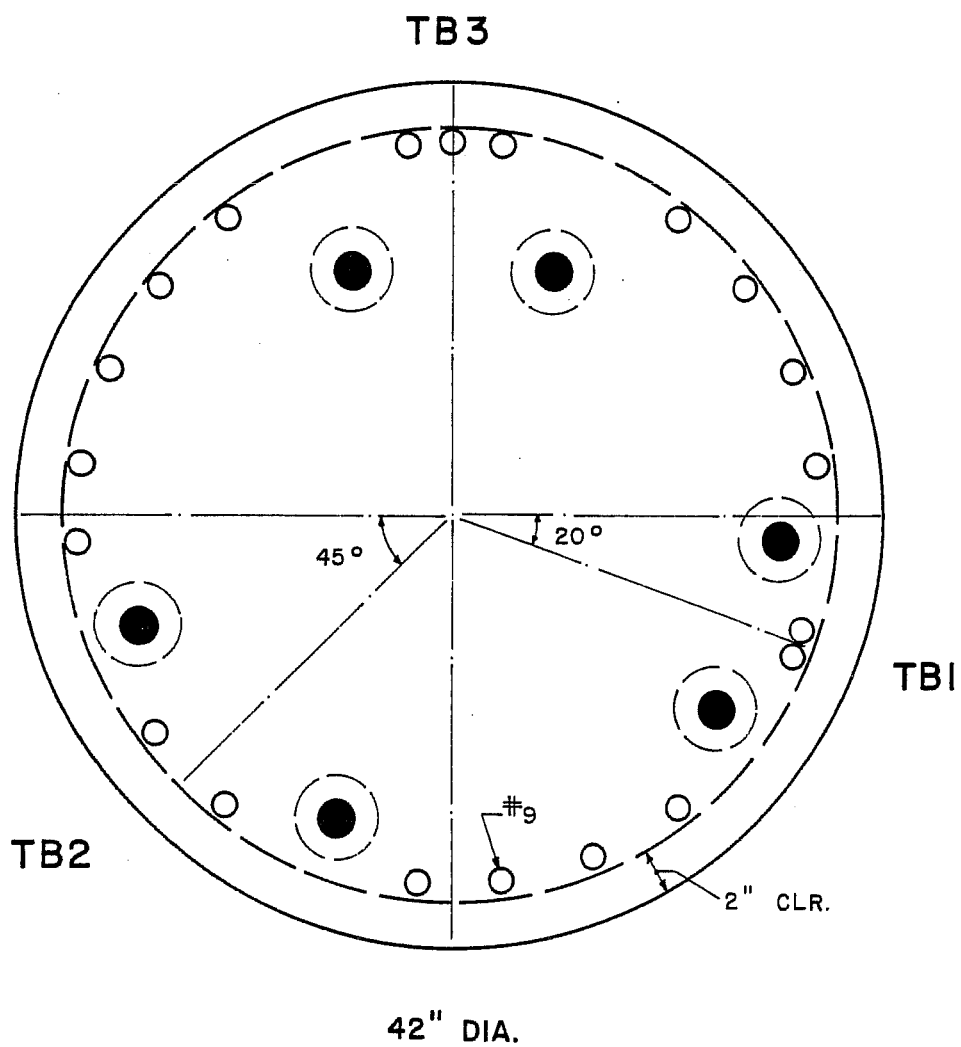
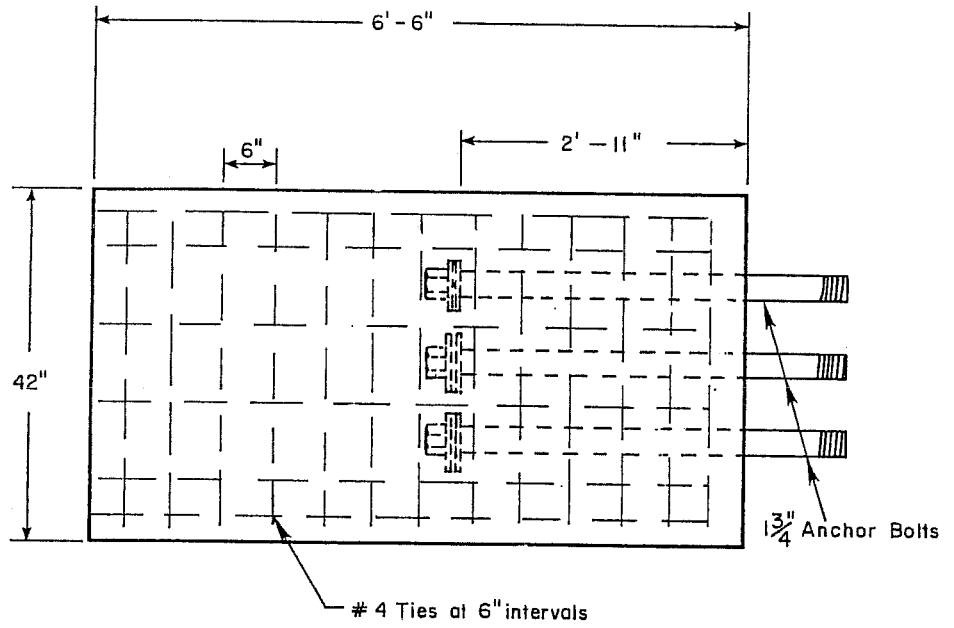
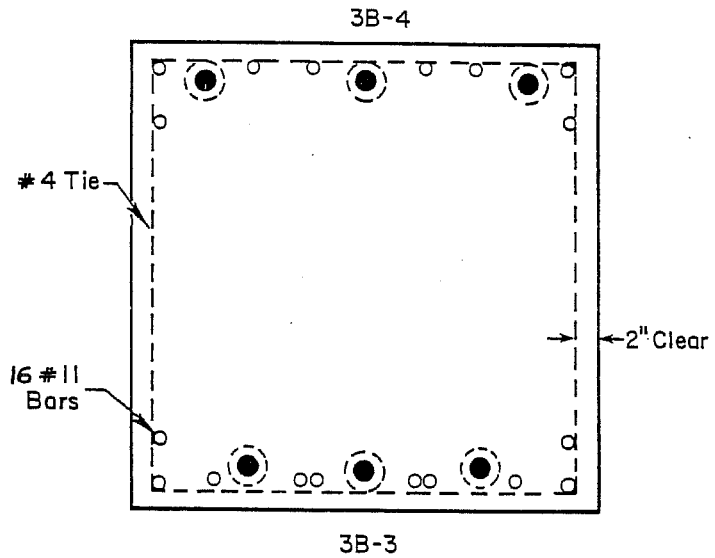

Fig. 3.4 Section of pier; 2-bolt groups



(a) Plan view



42 in. square pier

(b) Section through anchor bolts

Fig. 3.5 Square pier geometry and details

3.3.1 Anchor Bolts, Nuts, Washers. The materials used in the fabrication of the anchor bolts conformed to ASTM A193 Grade B7, with a minimum yield strength of 105 ksi and tensile strength of 125 ksi [14]. No stress-strain curve was obtained for the bolt material. Instead, a modulus of elasticity of 30,000 ksi, as suggested by the bolt supplier, was assumed in the analysis.

The end anchorage for each bolt consisted of an ASTM Specification A194 Type 2H (Heavy Hex) nut and 3/16 in. thick standard diameter (4.0 in.) washers. Thread for the bolts and nuts conformed to ANSI B1.1, BUN designation.

3.3.2 Concrete. Ready-mixed concrete was obtained from a local supplier. Normal weight concrete was designed for a nominal strength $f'_c = 3600$ psi. Type I cement, Colorado River sand and gravel, 1 in. maximum size, were used. An air-entraining agent, Septair, was added to the mix at the plant to provide 6% air. The mix design for specimens 1 and 5 (cast in warm weather) is shown below. About 80% of the water was

Concrete Mix Design ($f'_c = 3600$ psi)

Quantities per cubic yard

Cement	(5 sacks/cu.yd.)	470 lb
Water	(5.5 gal/sack)	27.5 gal
Gravel		1890 lb
Sand		1375 lb
Entrained-air (Septair)		6%

added at the plant, the rest was added at the Laboratory to obtain a desired slump of 6 to 8 in. For specimens cast in colder weather, the cement content was decreased to 4.5 sacks/cyd, but the water-cement ratio was held constant at 5.5 gal/sack. Concrete compressive strength (f'_c) was determined from the average of three 6x12 in. standard cylinders. Concrete strength at the test date is listed in Table 3.2.

3.3.3 Steel Reinforcement. For the four-bolt groups, the spiral was fabricated from Grade 40, #4 deformed bars. Spirals in the two-bolt and hoops in the three-bolt tests were fabricated from #4 deformed bars. Grade 60, #9 and #11 longitudinal bars were used inside the spiral cage.

3.4 Fabrication

Commercially available circular cardboard tubes with a pre-oiled inside surface were obtained for the circular drilled shaft formwork. The tube was seated, plumbed, and secured to a wooden base. Next, a wooden bracing frame was assembled around the tube. Then, the instrumented spiral reinforcing cage was positioned inside the tube, as shown in Fig. 3.6. With the cage in place, a bolt template was

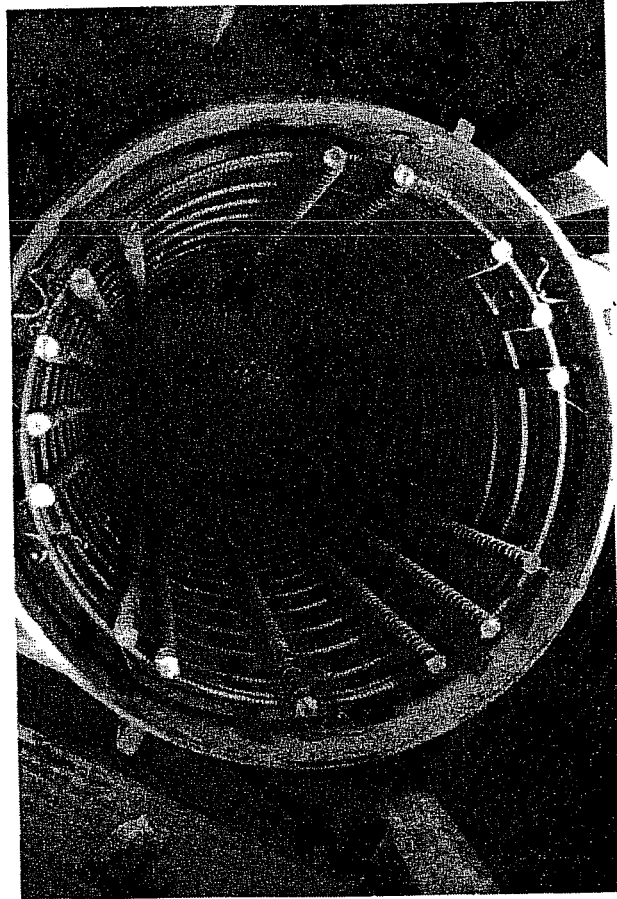

Fig. 3.6 Spiral cage in place

positioned above the tube, on top of the wooden frame. A square hole in the center of the template provided access for working inside the tube and for concrete placement. With the template in place, six instrumented bolts were positioned in the template and secured in the tube by means of #2 bars and tie wires to control bolt spacing and edge cover. A typical bolt group prior to casting is shown in Fig. 3.7. Finally, inserts were installed for the slip measurement devices, strain gage wires and slip wires were run outside the tube, lifting inserts were installed, and the base was coated with form oil. The formwork assembly prior to casting is shown in Fig. 3.8. The inside of the tube prior to casting is shown in Fig. 3.9. The square piers (three-bolt groups) were cast in a plywood form (Fig. 3.10). The reinforcement cage is shown in Fig. 3.11.

The specimens were cast in a vertical position. Concrete was placed in several lifts using a concrete bucket and overhead crane. Each lift was consolidated using a mechanical vibrator. Standard 6x12 in. cylinders were cast. The top of the specimen was troweled smooth, and the specimen and the cylinders were covered with polyethylene sheets. After three or four days, the specimen formwork was stripped and the cylinders were removed from the molds. The specimen and the cylinders cured under the same conditions until the day of testing.

Although care was taken to control bolt spacing and clear cover during concrete placement, slight shifting of the bolts occurred in most of the tests. Actual values of spacing and cover are given in Table 3.2.

3.5 Instrumentation

3.5.1 Strain Gages. Electrical resistance strain gages with a gage length of 0.64 in. were used to measure bolt strain. After preparation of the steel surface, the gages were attached with an epoxy adhesive and allowed to cure at least 24 hours. Lead wires were attached and the strain gage and lead connection were waterproofed with a silicone sealer and a polymer rubber pad.

The locations of the strain gages along each bolt are shown in Fig. 3.12. Strains were measured at three different locations along the bolt: (1) in front of the washer to measure bolt stress in the anchorage region (2 gages, 180° apart), (2) in the middle of the embedment length (1 gage), and (3) outside the concrete surface to measure stress in the anchor bolt at the face of the concrete (4 gages, 90° apart).

Spiral and transverse hoops were instrumented with 0.32 in. gage length strain gages. Gages were placed as shown in Figs. 3.13 and 3.14. In specimens TB7, TB8, and TB9, 0.64 in. gages were also placed on the

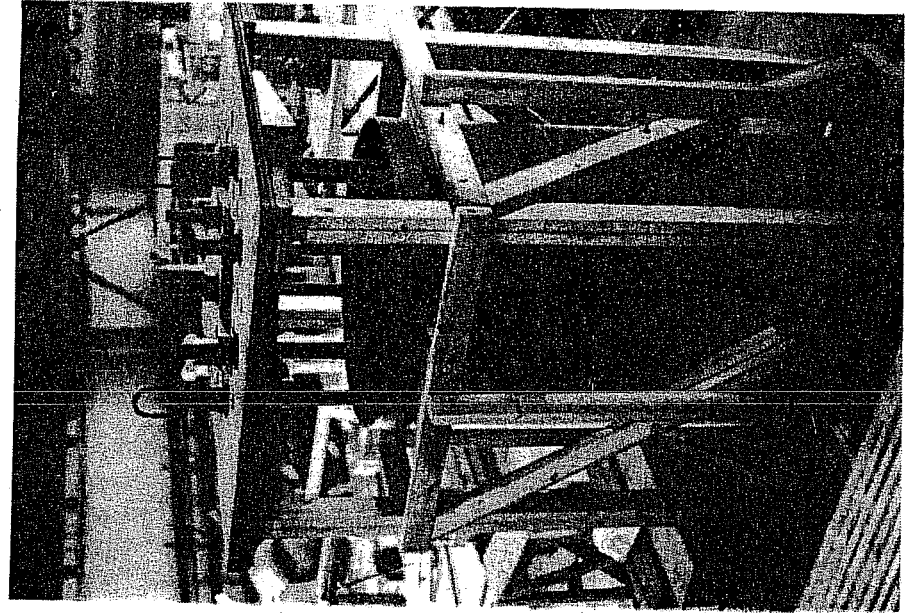

Fig. 3.8 Formwork assembly prior to casting

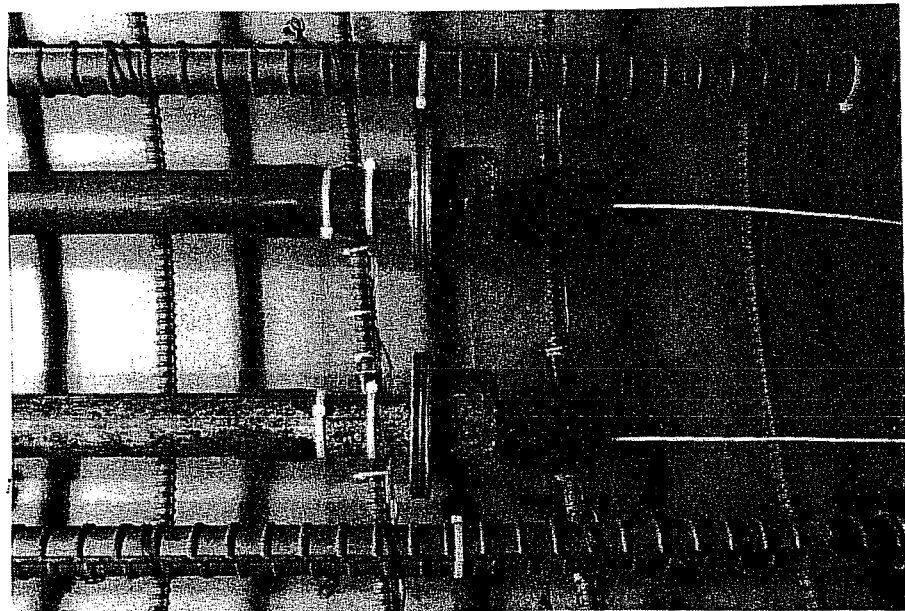

Fig.3.7 Bolts inside formwork

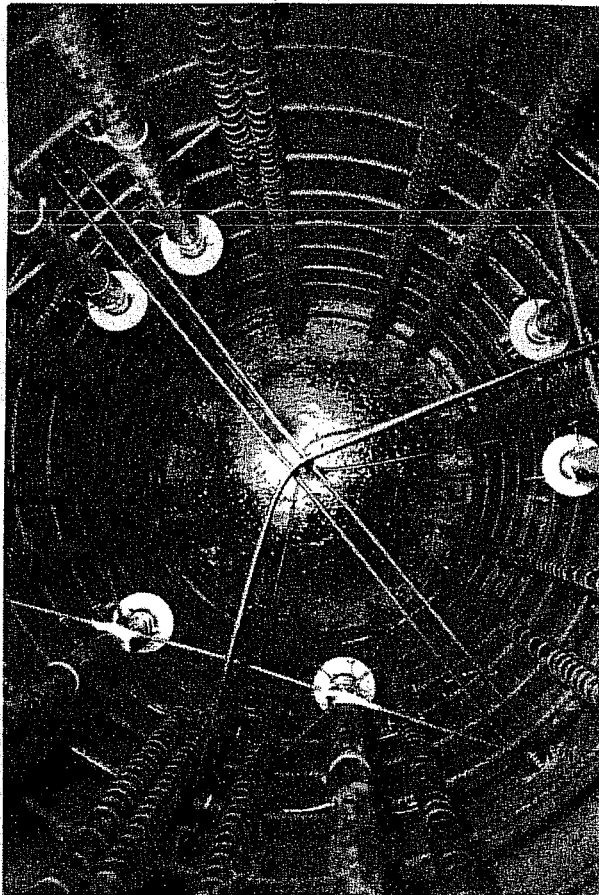

Fig. 3.9 Inside of tube prior to casting
(2-bolt group)

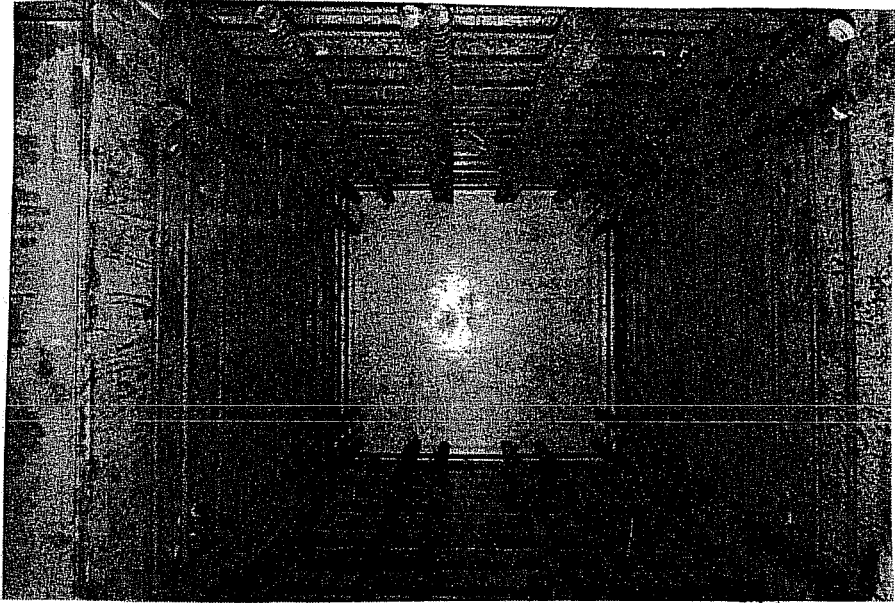

Fig. 3.11 Reinforcing cage inside formwork

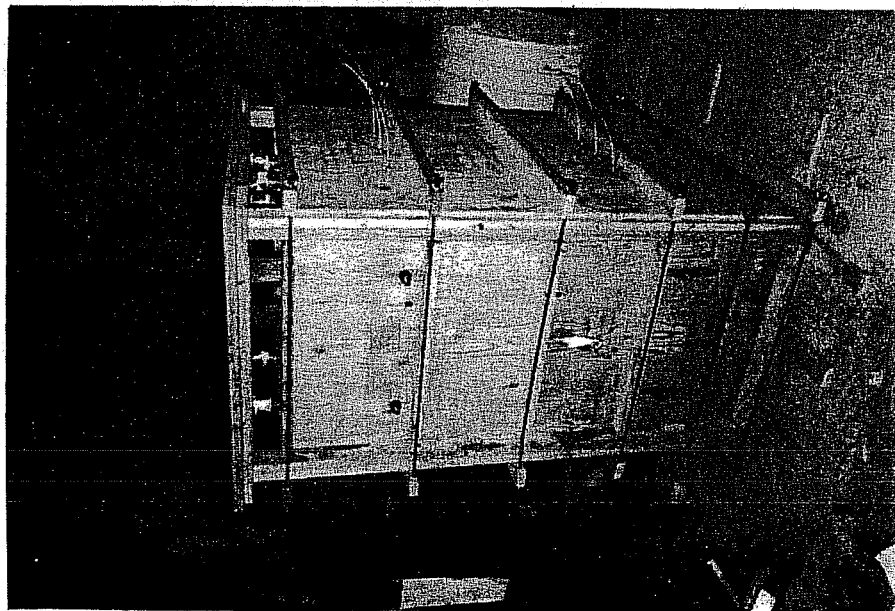

Fig. 3.10 Square pier formwork

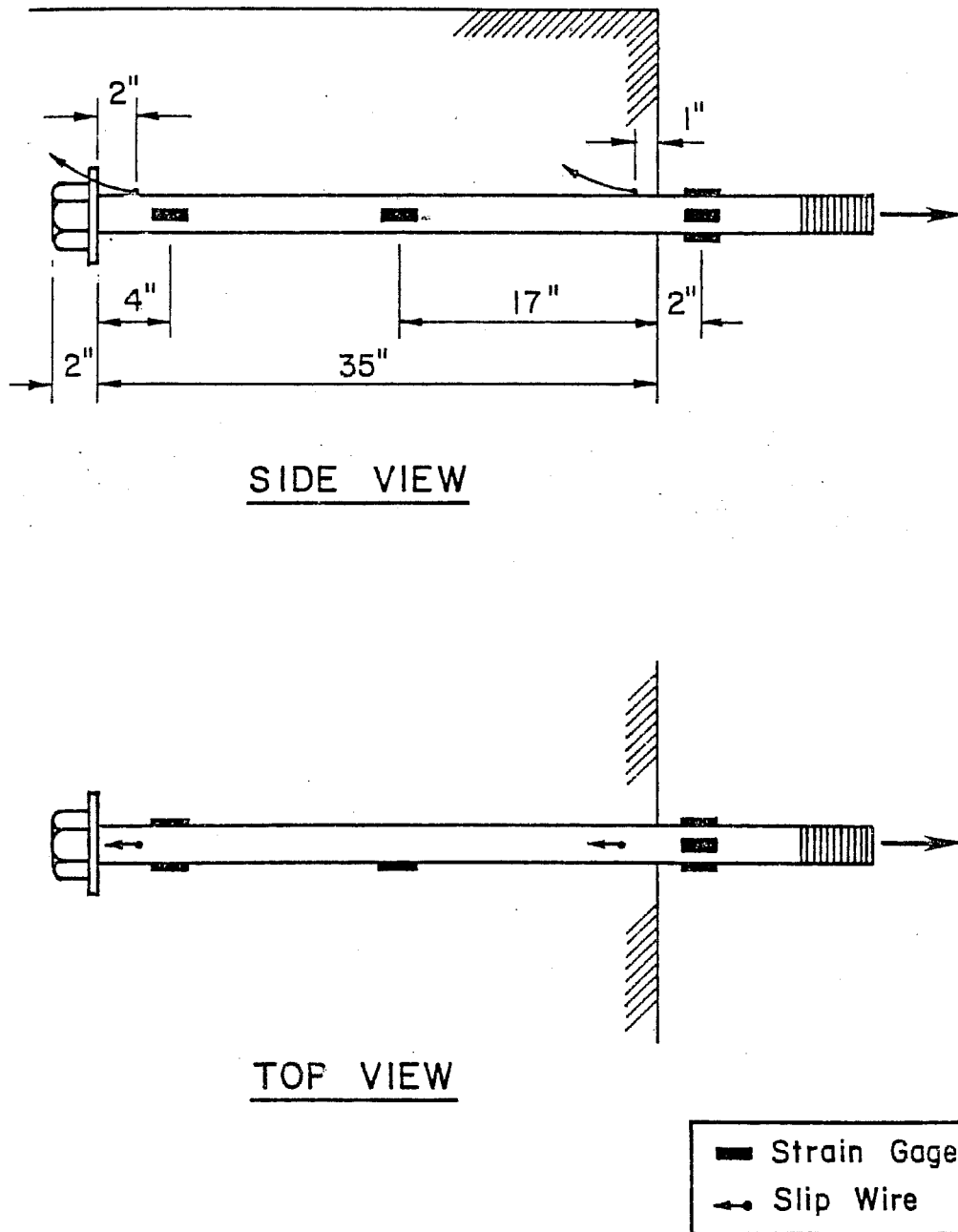

Fig. 3.12 Location of bolt instrumentation

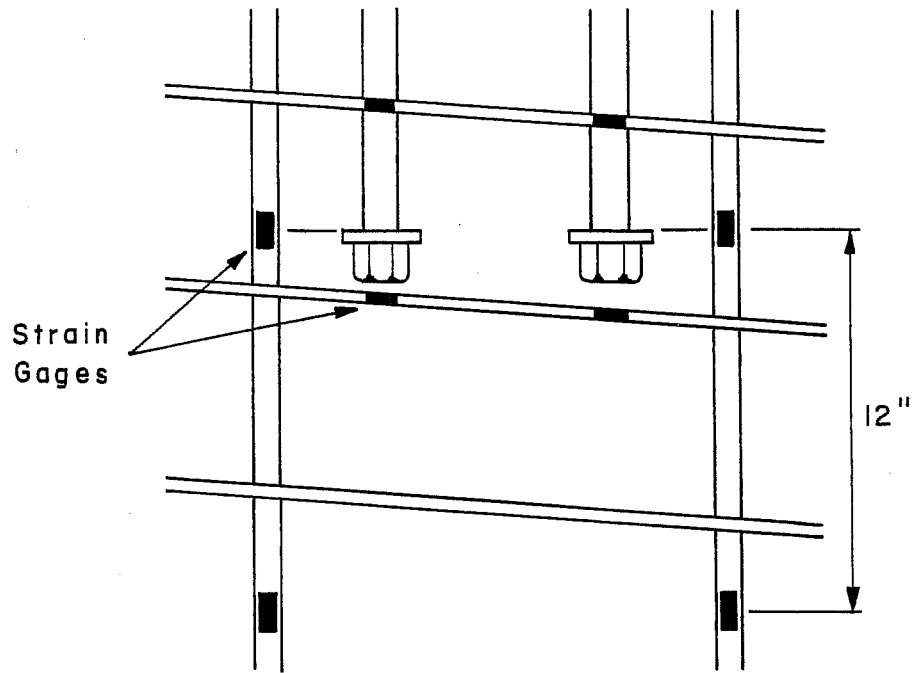
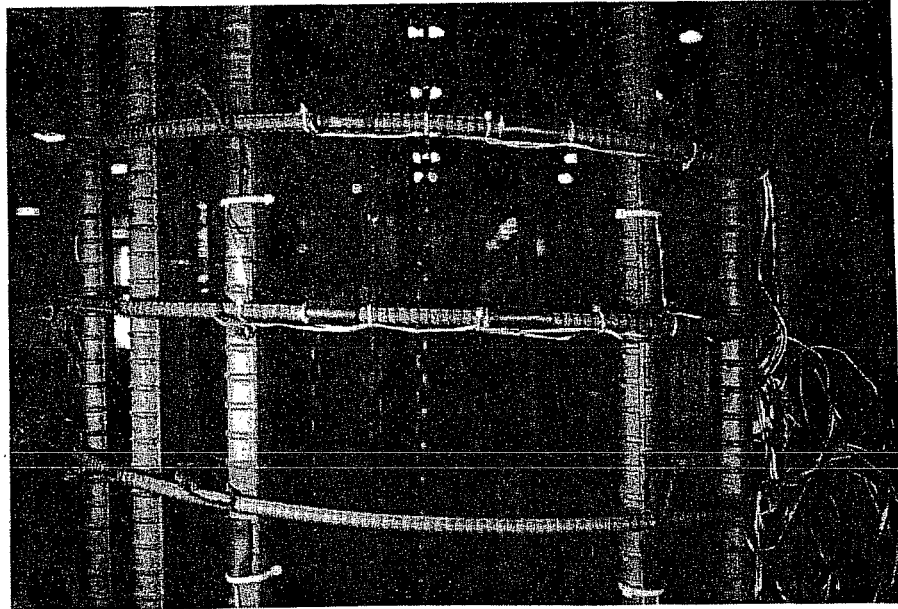

Fig. 3.13 Strain gages on spiral and longitudinal reinforcement

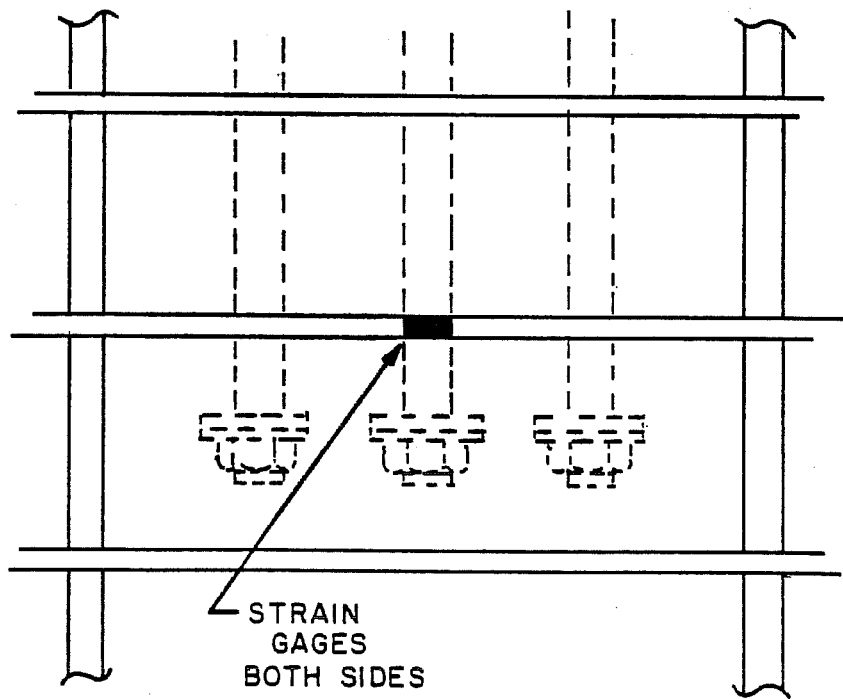
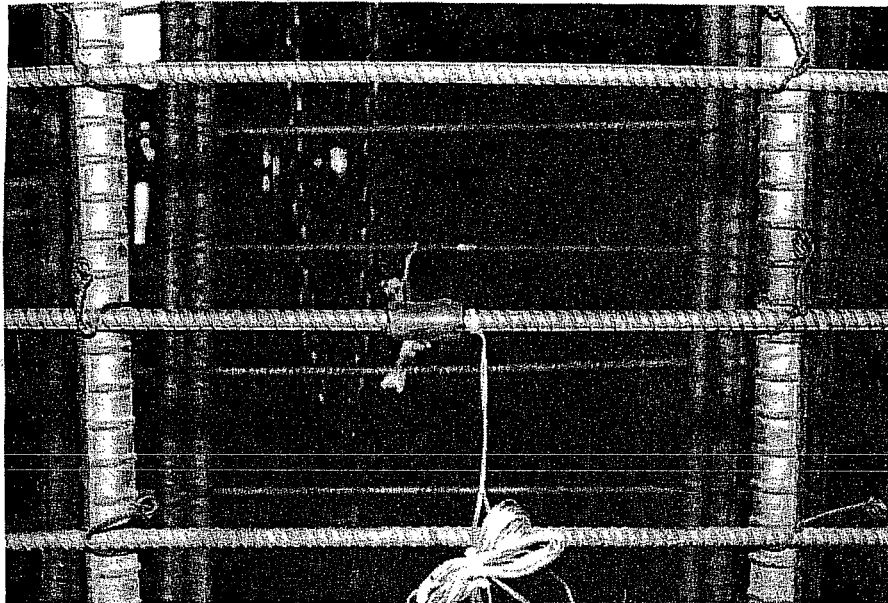

Fig. 3.14 Location of transverse reinforcement instrumentation

two longitudinal bars nearest to the bolts. The location of these gages is shown in Fig. 3.13.

3.5.2 Slip Wires. Slip of the anchor bolts relative to the concrete was measured by means of slip wires. As shown in Fig. 3.12, slip wires were attached to the bolt at two locations: (1) at the lead end, embedded 1 in. from the face of the concrete, and (2) at the tail end, 2 in. in front of the washers. To ensure that slip was measured relative to a stable reference point, the slip wires were extended from the bolt to the side of the specimen, which remained fairly undamaged until after ultimate load was reached.

The wire used for slip measurement was 0.059 in. diameter piano wire. The wire was cut to length, greased, and covered with plastic tubing to prevent bonding and to allow free movement of the wire. The wire was then attached to the anchor bolt by making a short 90° bend at one end of the wire and inserting it into a hole of equal diameter drilled into the bolt. The plastic tube was sealed at the bolt end to prevent cement from entering the tube. The wire was oriented parallel to the bolt axis in the direction of slip. Figure 3.15 shows details of the instrumentation at both the lead end and the anchorage end of the bolt, respectively. Note that the tail slip wire passed through a small hole drilled in the washers.

An electrical resistance potentiometer was used to measure movement of the slip wire relative to the concrete surface. The shaft of the potentiometer rested against an aluminum plate at the end of the slip wire. A spring was used to tension the wire and thus reduce wobble within the plastic tube. The slip measurement device mounted on the specimen is shown in Fig. 3.16.

3.6 Loading System

In general, the method of loading used in this study simulated wind forces on typical drilled shaft footings. A beam oriented along the longitudinal axis of the bolts was loaded with a concentrated load at its end, thus producing an "overturning" moment at the bolt connection. The shear reaction, however, was not transferred into the bolts as in an actual footing; rather, the bolts were loaded in tension only.

Figures 3.17 and 3.18 are schematic drawings of the test frame. The front, upper rear, and lower rear pedestals are reinforced concrete collars. The rear of the specimen was tied to the test floor by the rear reaction assembly. A cross beam transferred the rear reaction from the upper rear pedestal to four high-strength rods secured into the test floor. The lower rear pedestal served only as an aid in aligning the specimen during placement and to support the specimen dead weight until testing.

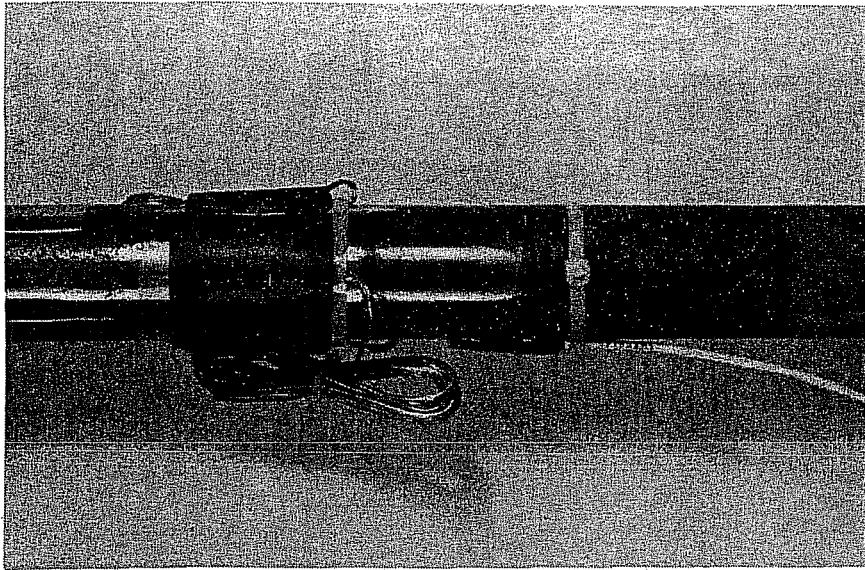

(a) Lead slip wire and gages

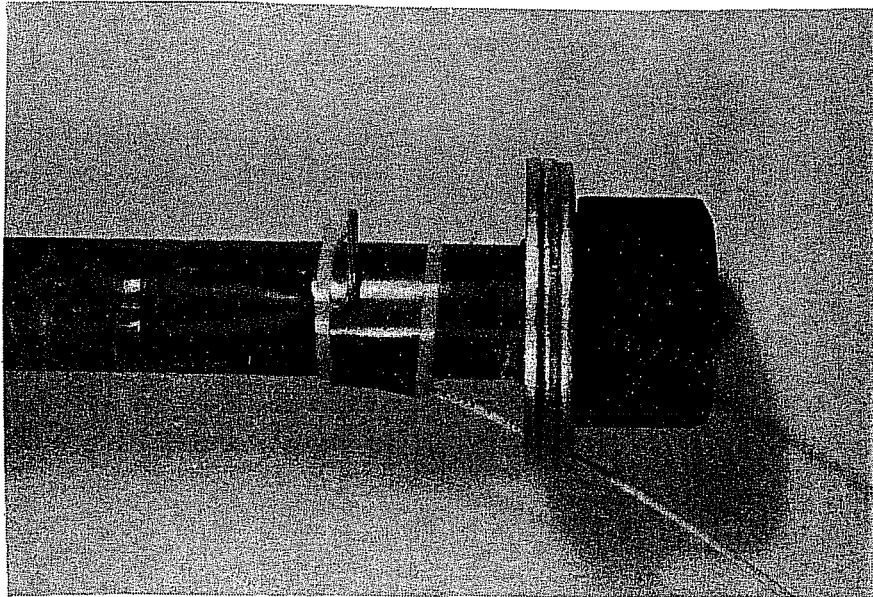

(b) Tail slip wire and gages

Fig. 3.15 Bolt instrumentation

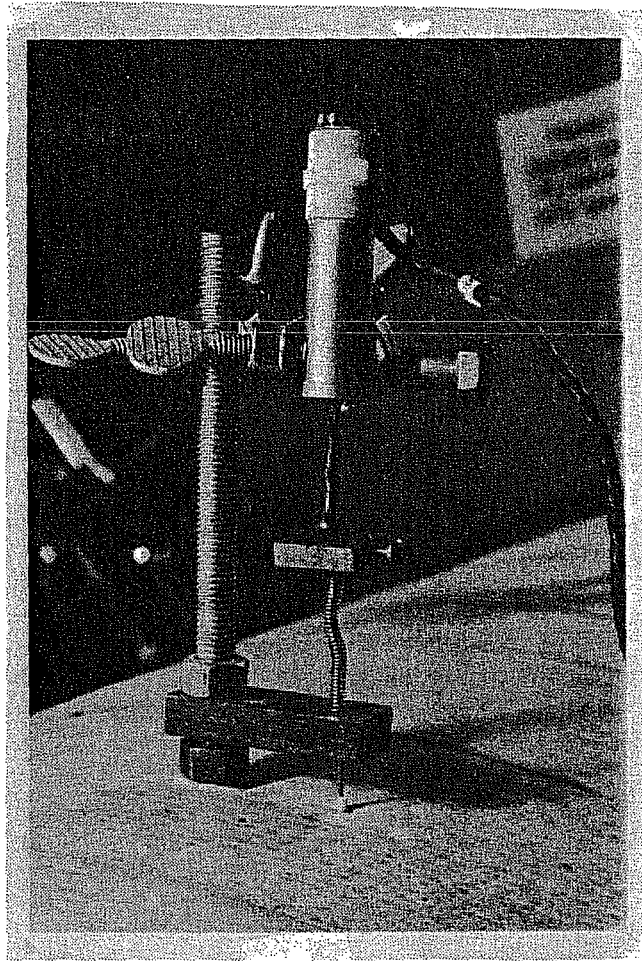

Fig. 3.16 Slip measurement device mounted on specimen

TEST FRAME

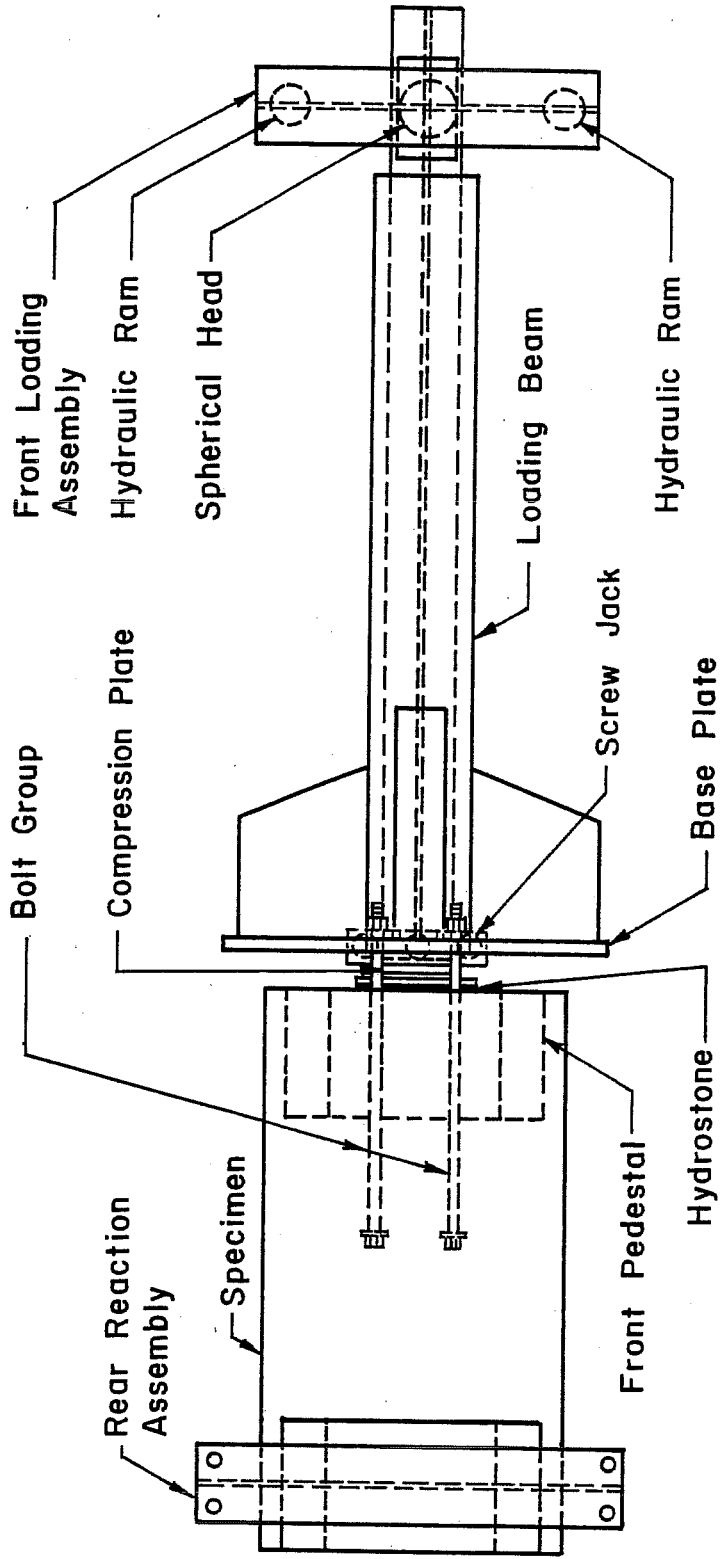

Fig. 3.17 Test frame--plan view

TEST FRAME

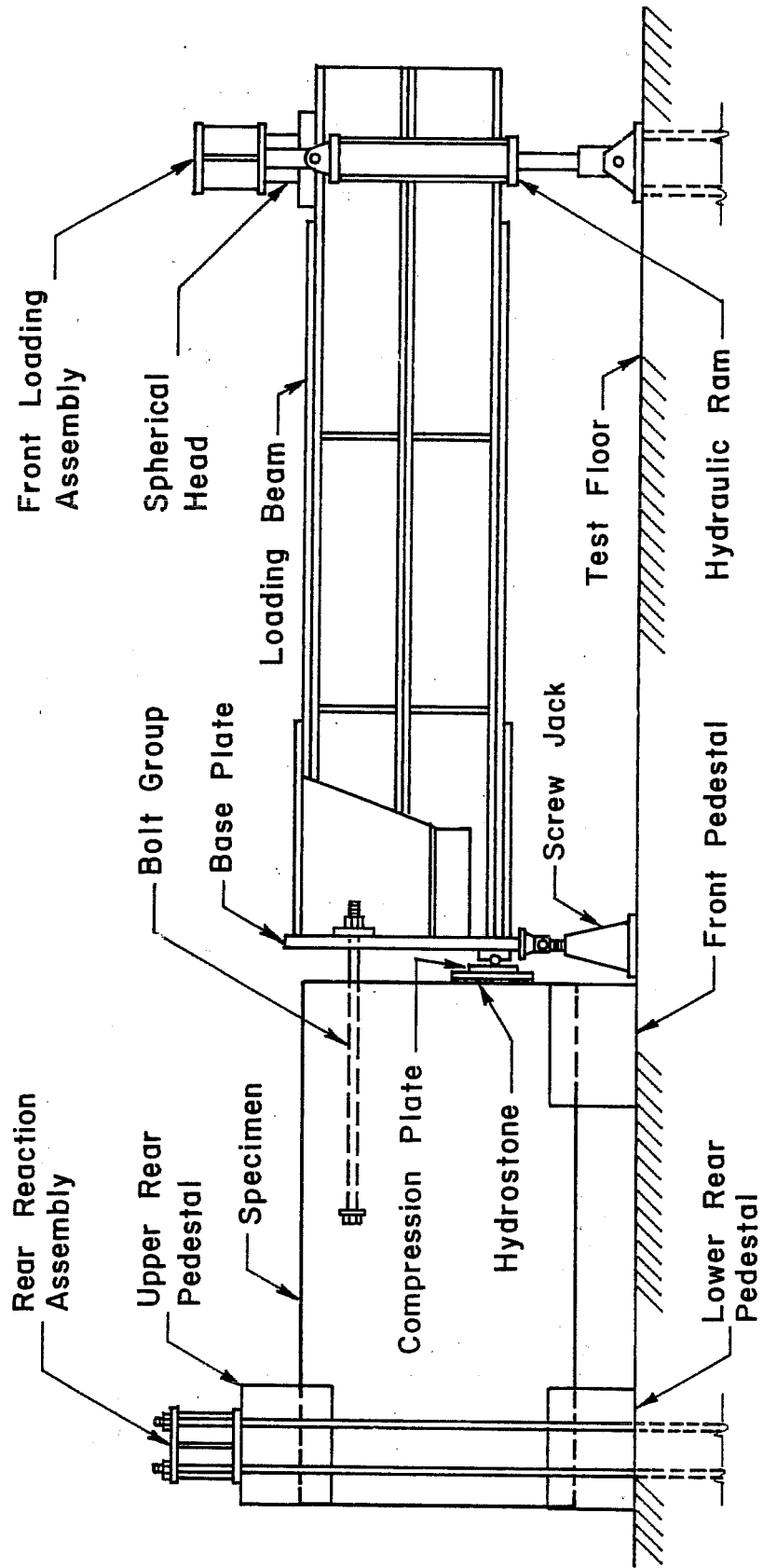

Fig. 3.18 Test frame--elevation

The loading beam was fabricated from two W14x53 wide-flange sections reinforced with two 1 in. x 8 in. cover plates. A 1-1/2 in. thick slotted base plate was welded to the connection end of the beam and stiffeners were added to increase the rigidity of the base plate. Nuts, washers, and plates were used to fix the anchor bolts to the loading beam. Load was transferred from the hydraulic rams to the loading beam through a cross beam and a spherical head which compensated for small misalignments of the loading beam.

For most of the tests, the bolts being tested protruded from the specimen through the slots provided in the base plate of the loading beam. However, the bolts with close spacings (4 in. and 6 in.) and three-bolt groups could not be accommodated by the existing loading beam. Therefore, a transfer beam was used to link the bolts to the loading beam. This change necessitated a wider gap to be provided between the specimen and the loading beam. The gap was filled with hydrostone mixed with sand. The specimen loading beam interface for these tests is shown in Fig. 3.19.

A concentrated load was applied to the end of the loading beam by means of two 70-ton hydraulic rams reacting against the test floor. To ensure that each ram was applying approximately the same load to the cross beam, the rams were connected in parallel by means of a manifold placed in the hose lines. The rams were operated by either an electric pump or a hand pump. Hydraulic line pressure was measured by means of a 10,000 psi pressure transducer.

Figure 3.20 shows an overall free body diagrams of the specimen and loading beam, and a free body diagram for the loading beam only. The bending moment at the face of the specimen was resisted by a force couple consisting of the tension in the two bolts and a compressive force which was transferred to the specimen by means of a bearing plate.

The specimens were cast in a vertical position and were tested horizontally. By means of lifting inserts in the sides of the specimen, it was lowered to the horizontal position with the desired test bolts on the top face. For subsequent tests on the same specimen, the specimen was removed from the test frame, rotated until the desired test was on the top face, and replaced in the test frame.

The specimen was set on the lower pedestals with a thin layer of mortar to ensure a uniform bearing surface. The rear reaction assembly was then positioned onto the specimen with a thin layer of mortar between the reaction assembly and the specimen. With the specimen in place, the loading beam was positioned over the anchor bolts and supported on jacks. Then the front loading assembly was set in place at the end of the loading beam. With the rams bolted to the floor, a thin layer of hydrostone was placed between the face of the specimen and the compression plate assembly. Figure 3.21 shows the test setup prior to testing.



(a) Top view

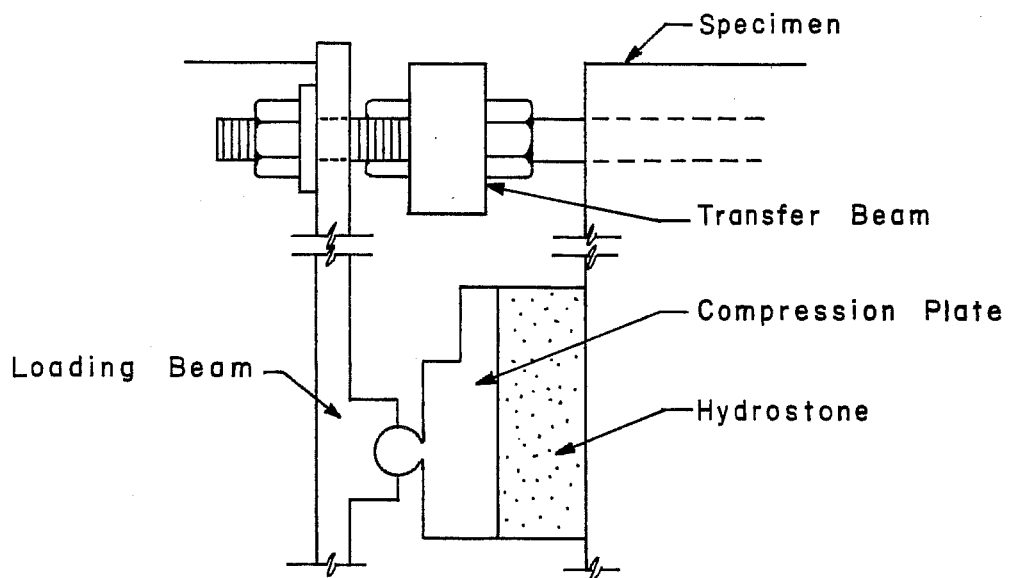

(b) Side view

Fig. 3.19 Specimen--loading beam interface

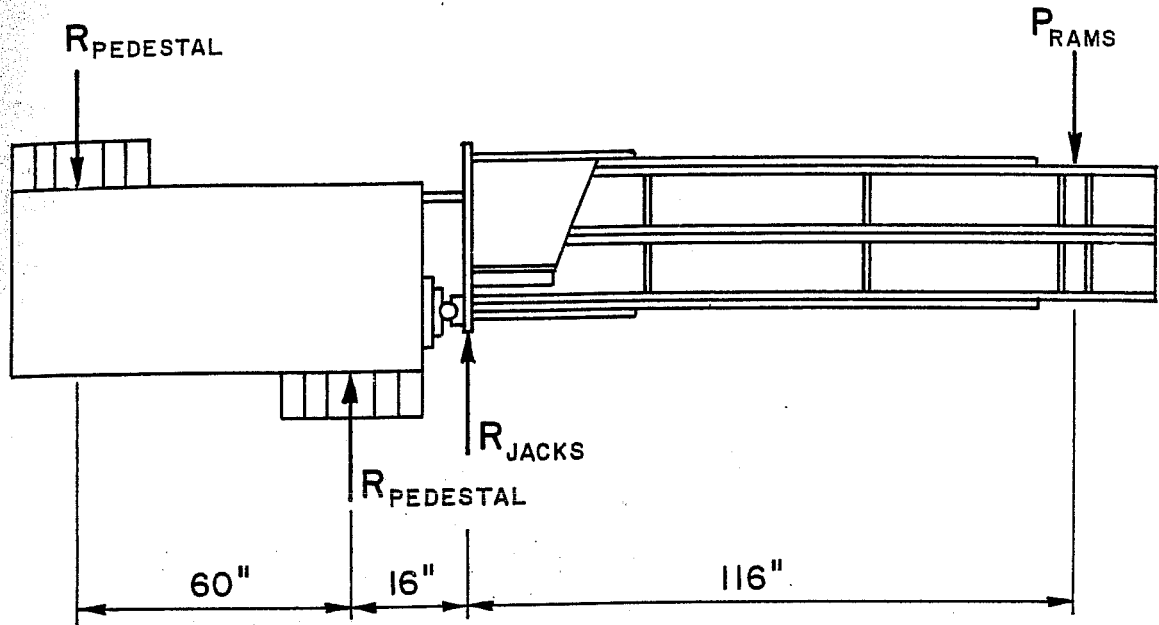

(a) Specimen and loading beam

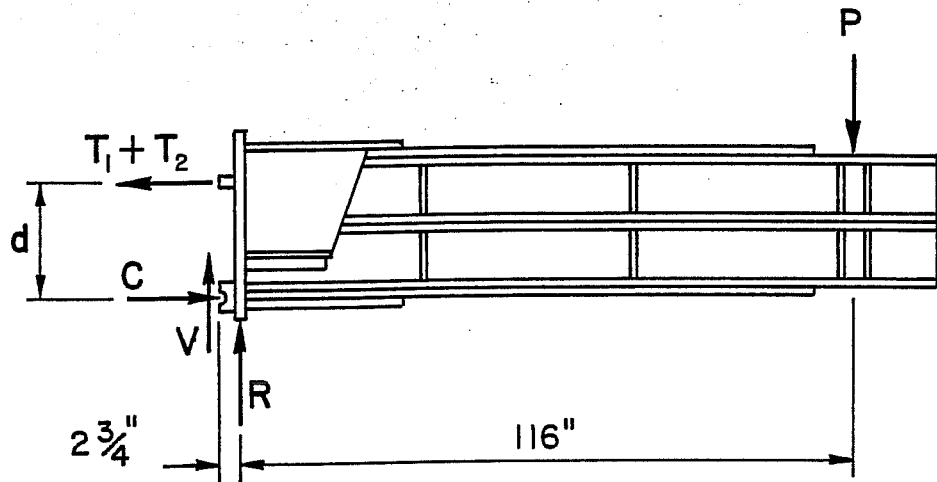

(b) Loading beam

Fig. 3.20 Free body diagrams of test setup

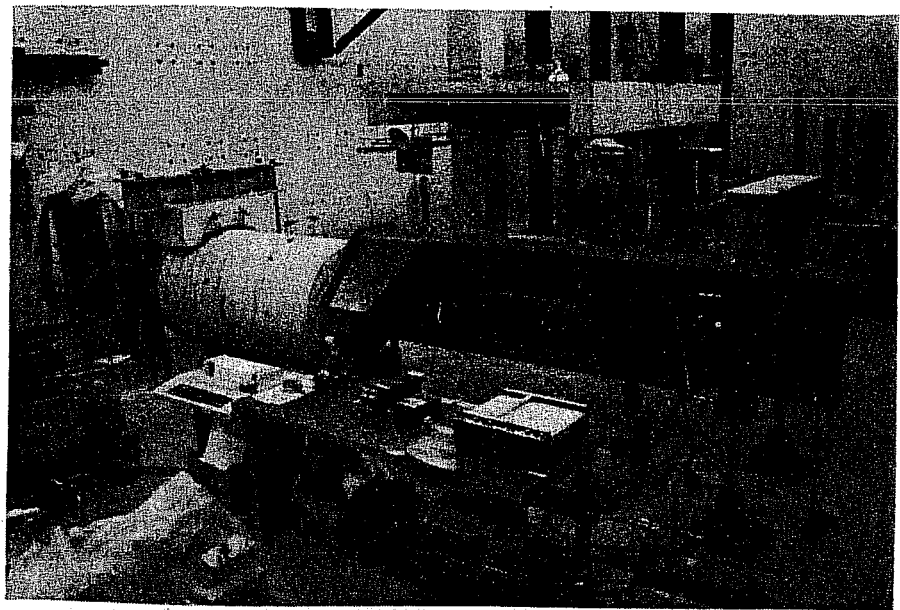

Fig. 3.21 Test setup prior to testing

3.7 Test Procedure

In general, the test procedure was the same for all tests. Load from the hydraulic rams was applied to the loading beam incrementally until ultimate load was reached. A preloading sequence was used to correct apparent asymmetrical loading of several four-bolt groups. A plot of applied ram load vs end deflection of the loading beam was used to monitor load during the test. At each load stage, all strain gages and slip potentiometers were read. The test surface was examined and cracks were marked. In addition, the development of crack patterns was documented with photographs.

"Failure" was defined as the point at which it was no longer possible to increase the load. For the first tests on each specimen, load was removed as soon as possible after failure to avoid unnecessary damage to the specimen which might offset subsequent tests. In most of the tests, the load dropped abruptly after failure occurred.

A data acquisition system scanned output signals from the strain gages, slip potentiometers, and pressure transducer, and converted the signals into digital voltages. At each load stage, output channels were scanned and voltages were recorded on a magnetic tape for future data reduction. In addition, a hard copy of the data was printed at the test site for use in monitoring selected data channels during the test.

CHAPTER 4

TEST RESULTS

4.1 Introduction

In this chapter, a general description of bolt group behavior is presented, including bolt tension versus bolt slip curves. Crack patterns are described. The effect of transverse reinforcement on bolt group behavior is examined. The behavior of 2-, 3-, and 4-bolt groups is compared.

Terms used to describe the geometry of the anchor bolt installations are illustrated in Fig. 4.1. Other terms used in the presentation and discussion of the results are defined as follows:

- (1) Applied Load (P) - total load measured at the hydraulic rams.
- (2) Bolt Tension (T_p) - calculated tensile force on an individual bolt in a group.
- (3) Ultimate Bolt Tension (T_{max}) - tensile capacity of an individual bolt in a group.
- (4) Isolated Bolt Capacity (T_i) - predicted ultimate force on individual bolts in a group if acting independent of one another.
- (5) Lead Slip, Lead Stress - bolt slip and stress measured at the face of the concrete.
- (6) Mid Stress - bolt stress measured at the middle of the embedment length.
- (7) Tail Slip, Tail Stress - bolt slip and stress measured in front of washer at the anchorage end of the bolt.

Bolt forces were determined directly from strain measurements on each bolt. The tensile force on a bolt was calculated using average strain from the lead strain gages (see Fig. 3.12). The bolt force determined from strain measurements was checked against the expected bolt force as calculated from the applied load and the geometry of the test frame. Figure 4.2 shows the correlation between the applied moment on the bolt group as calculated from the applied load versus the resisting moment as calculated from the measured bolt force for three of the tests. The correlation shown in Fig. 4.2 was typical of all tests.

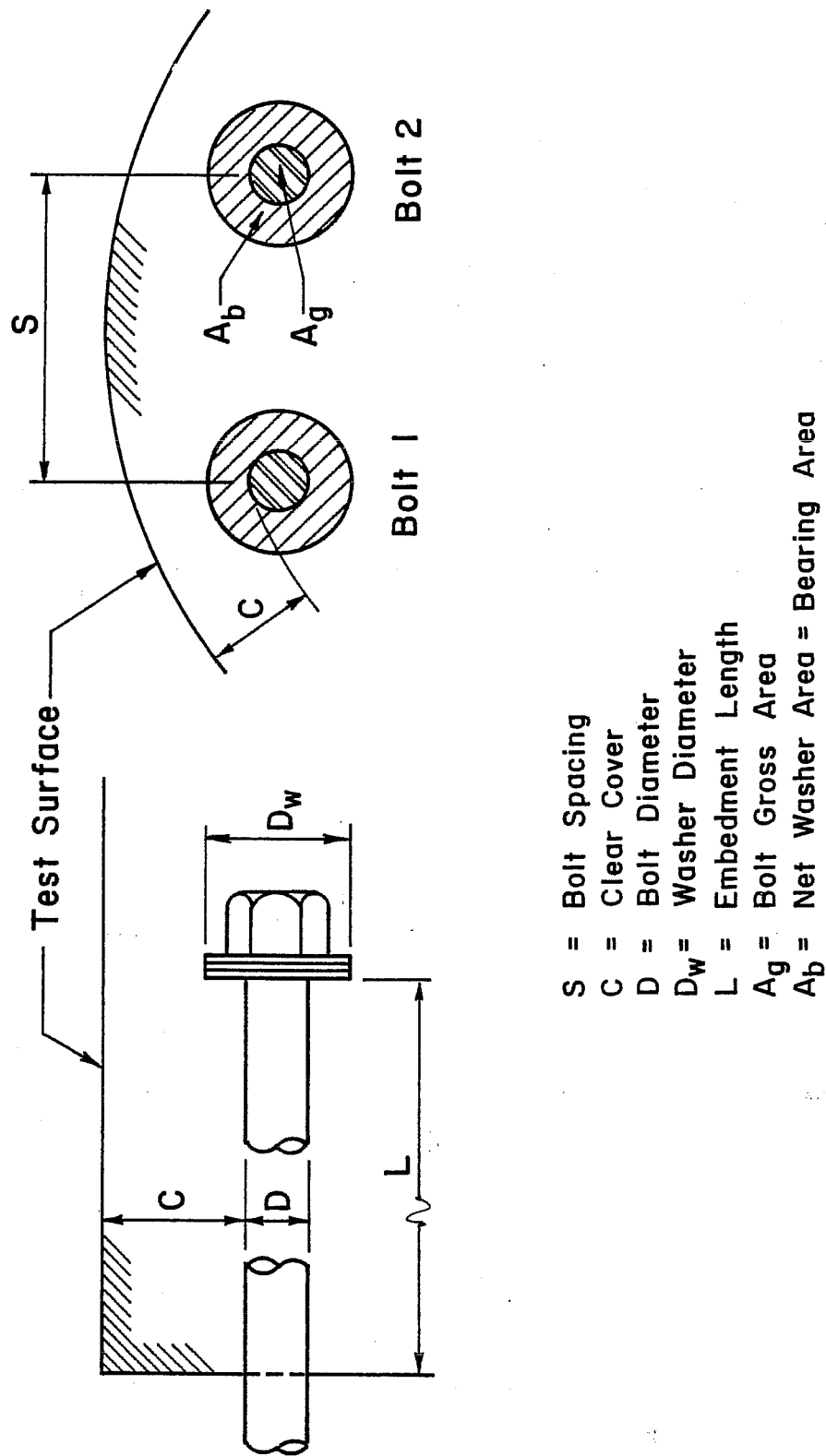

Fig. 4.1 Nomenclature for bolt group installation

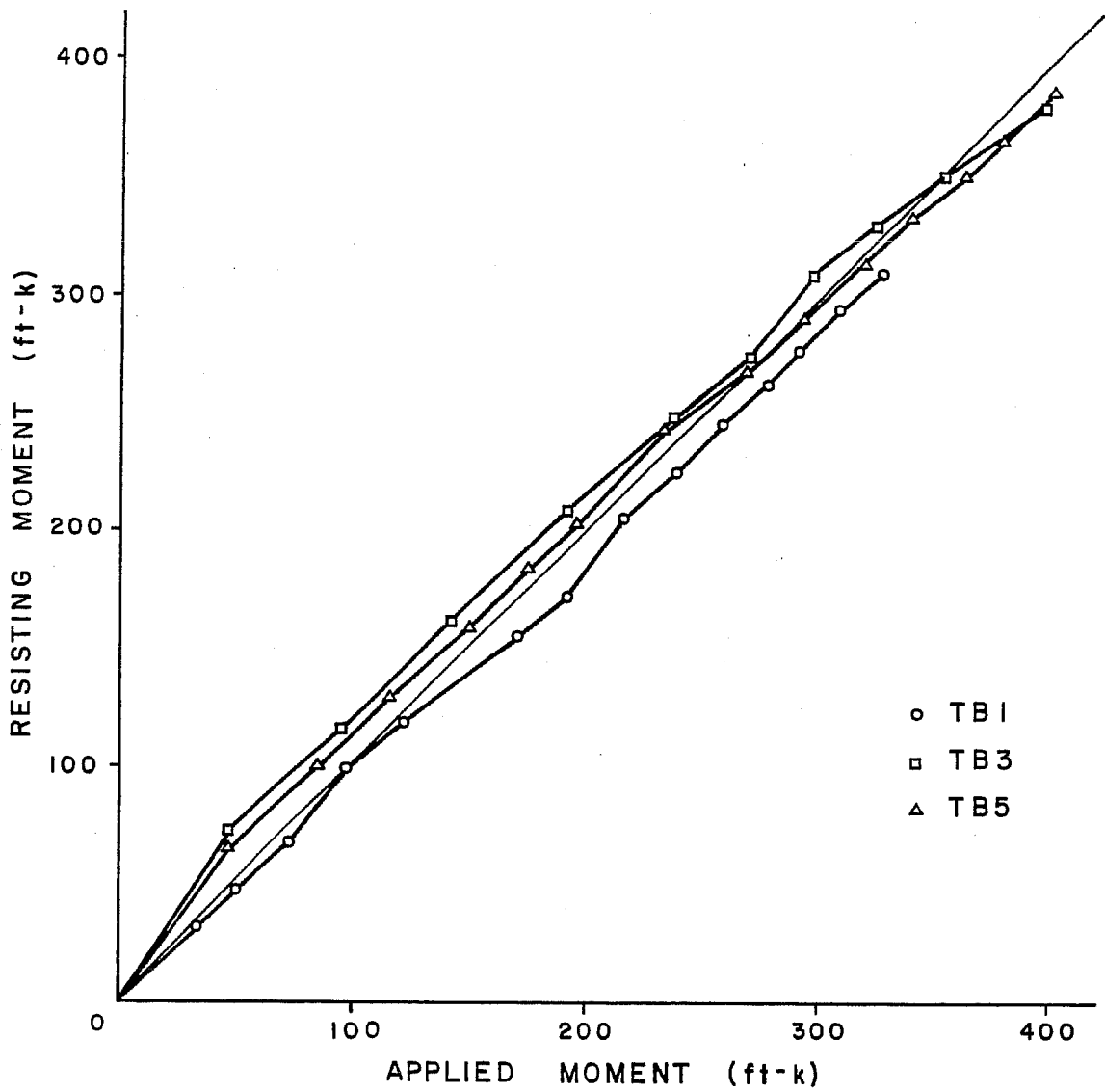

Fig. 4.2 Consistency of test data with overall equilibrium (2-bolt groups)

4.2 General Response under Loading

For the bolt group orientation and method of loading used in the tests, equal forces would be expected for the bolts at each level. In general, nearly equal forces were observed. Figure 4.3 illustrates the difference between bolt forces during loading for three different tests. Differences are more pronounced at lower load stages.

In the four-bolt groups, the upper-level bolts resisted most of the moment until they reached failure. The bolts at the lower level then gained load at a faster rate as the upper-level bolts were unable to carry increased load or to hold the load applied. In terms of average values, the load on the lower-level bolts was $1/4$ to $1/2$ of the top bolt load at $2/3$ of the group capacity, and $1/2$ to $2/3$ of the top bolt load when the group reached its capacity.

In the three-bolt groups, the center bolt (bolt #2) was stressed to a higher level than the two outer bolts (bolts #1 and #3). This may have been due to bending of the transfer beam and possibly bending of the base plate of the loading beam. Although the transfer beam was designed to minimize this type of deflection, it is impossible to eliminate it completely.

Table 4.1 is a summary of the bolt forces at ultimate for all of the tests. Differences between bolts were probably due to asymmetric loading caused by misalignment of either the specimen itself or the transfer beam between the specimen and the loading beam.

With strain gages located at three positions along the bolt, it was possible to examine the stress variation along the bolt during testing. Figure 4.4 shows mid and tail stress plotted against lead stress for both bolts in test TB8. At early load stages, bond between the bolt and the concrete is the predominant load-carrying mechanism; very little increase in mid or tail stress is observed with increasing lead stress. As load increases, bond strength deteriorates along the length of the bolt and the load previously transferred by a bond mechanism is carried in bearing against the washers. Thus, at ultimate load, mid and tail stresses are almost equal to lead stresses.

4.3 Load-Slip Relationships

Bolt tension versus lead slip curves are shown in Figs. 4.5 through 4.15. Bolt tension was calculated from strain measurements on each bolt. Lead slip data were taken directly from slip readings. In some tests the slip measuring system did not record at early load stages, probably due to slack or wobble in the slip wire. In these cases, a correction was made to approximate the initial slip response. The same scale is used for lead slip in each plot in order to make comparison of behavior easier. In general, the load-slip response of both bolts in

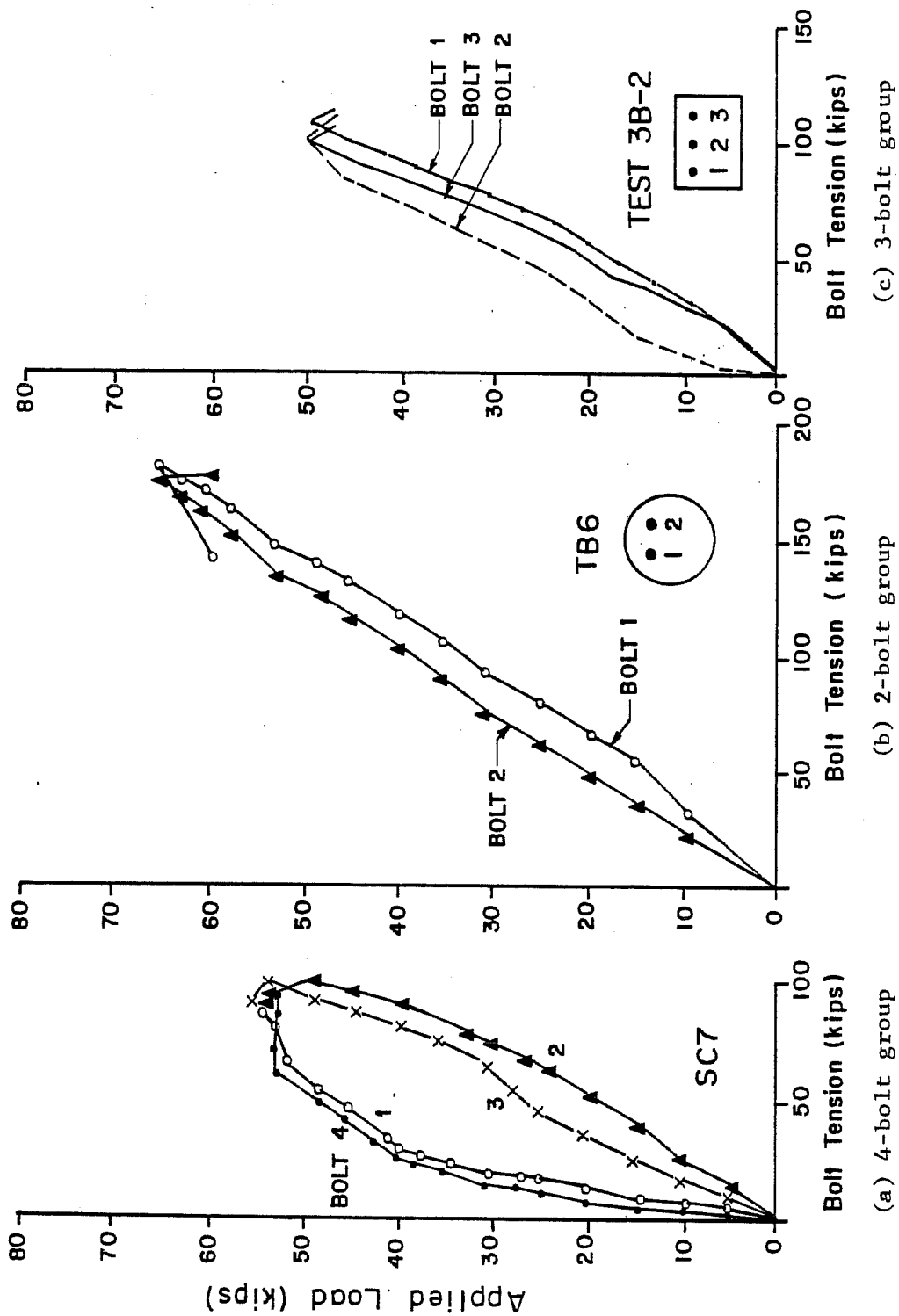

Fig. 4.3 Bolt stress variation during testing

Table 4.1 Bolt forces at ultimate on group

	T_b /kips			
	Bolt 1	Bolt 2	Bolt 3	Bolt 4
<u>4-Bolt Groups (circular shaft)</u>				
SC1	*	99	81	*
SC2	*	*	*	*
SC4	*	*	*	*
NOW	38	97	92	69
SC6	60	126	127	85
SC7	62	93	92	60
SC8	103	150	149	106
STG1	8	112	99	49
STG2	86	133	122	75
<u>2-Bolt Groups (circular shaft)</u>				
TB1	114	110		
TB3	147	157		
TB4	124	118		
TB5	127	110		
TB6	180	174		
TB7	87	102		
TB8	102	110		
TB9	168	172		
<u>3-Bolt Groups (square pier)</u>				
3B-1	56	87	91	
3B-2	99	104	102	
3B-3	119	116	72	
3B-4	92	132	96	
3B-5	---	146	---	

* Not available

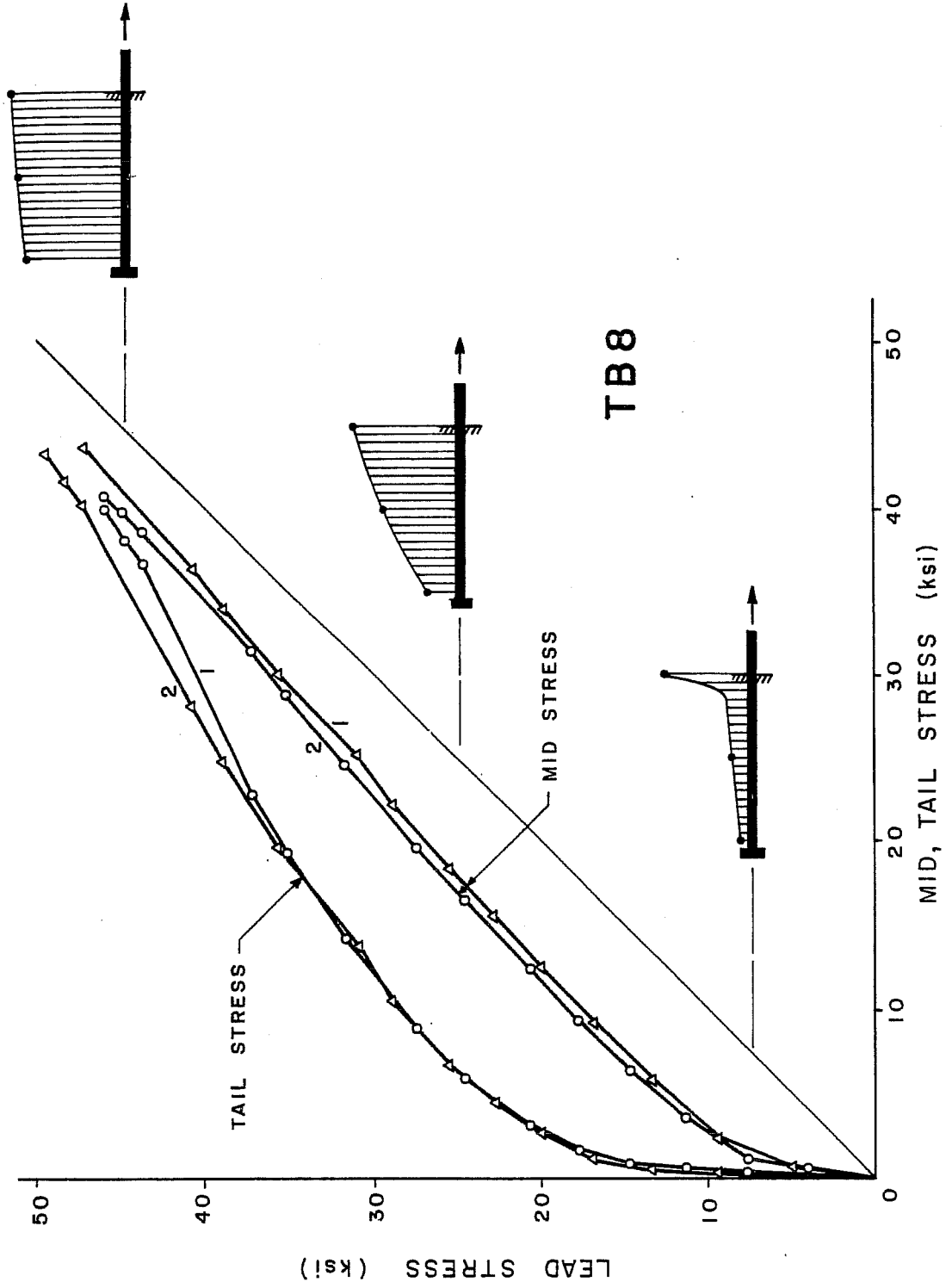

Fig. 4.4 Stress variation along bolt

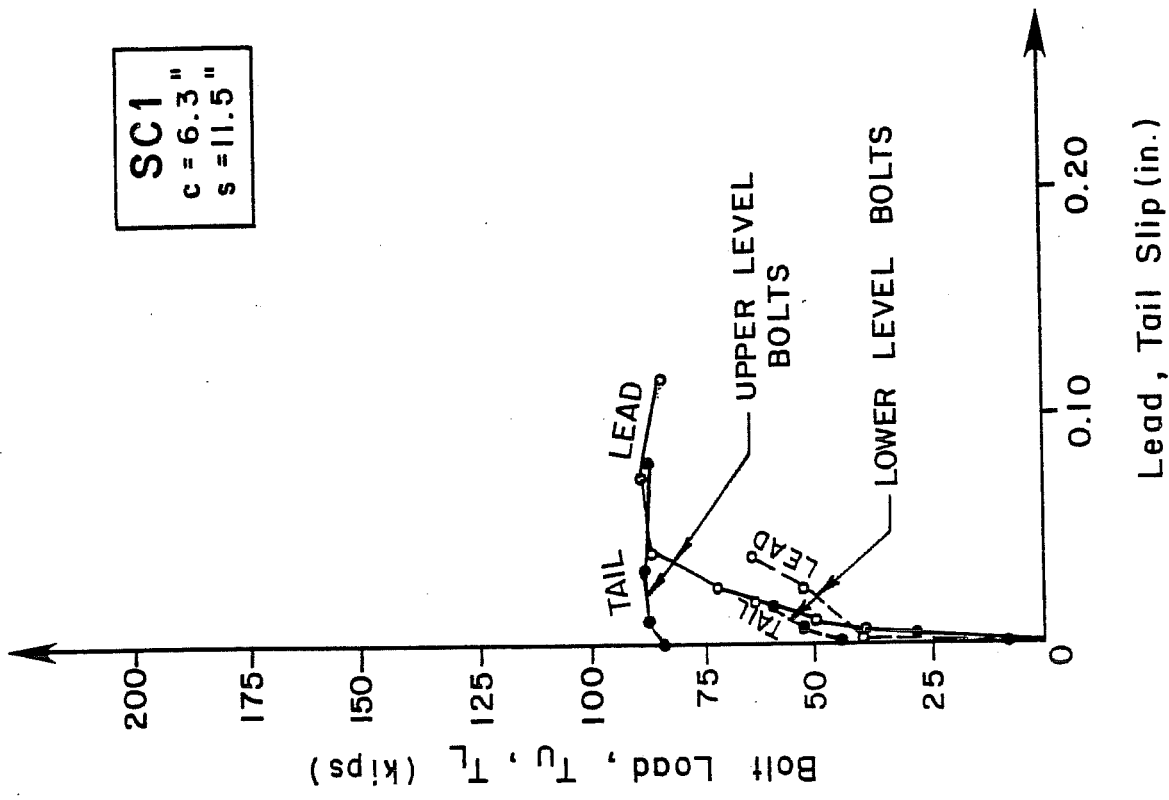
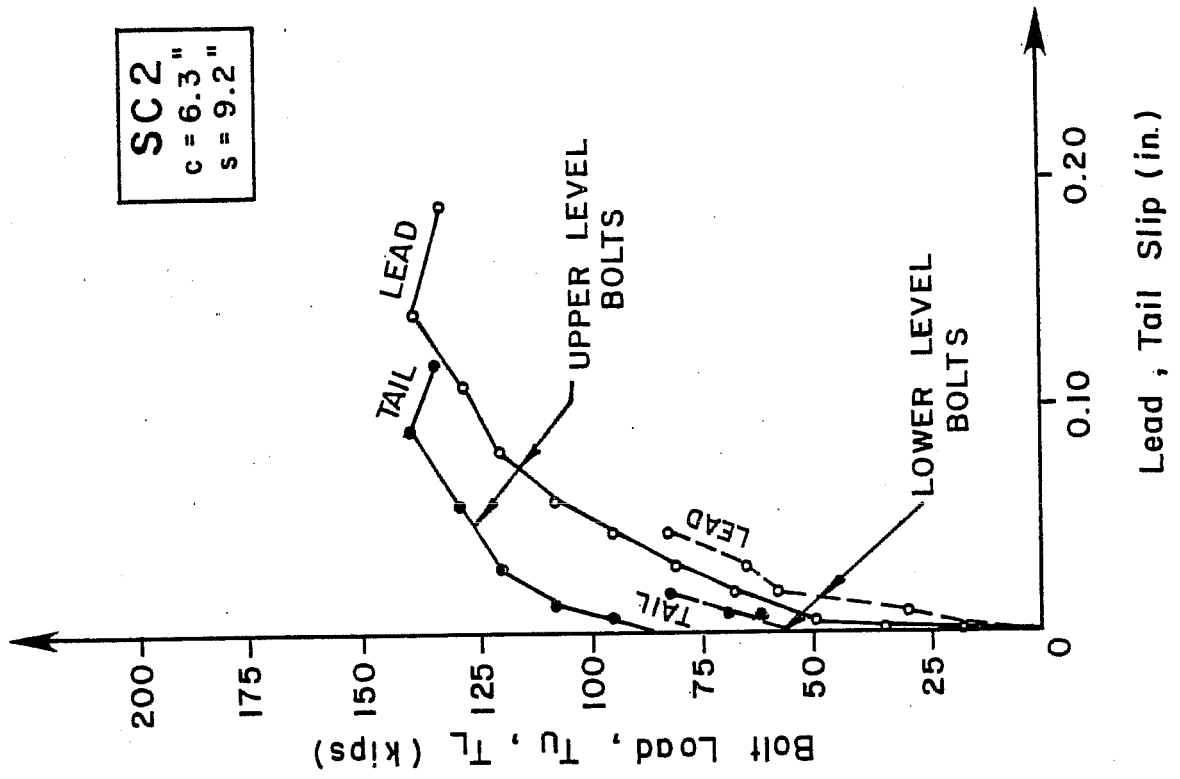

Fig. 4.5 Load-slip curves, SC1 and SC2

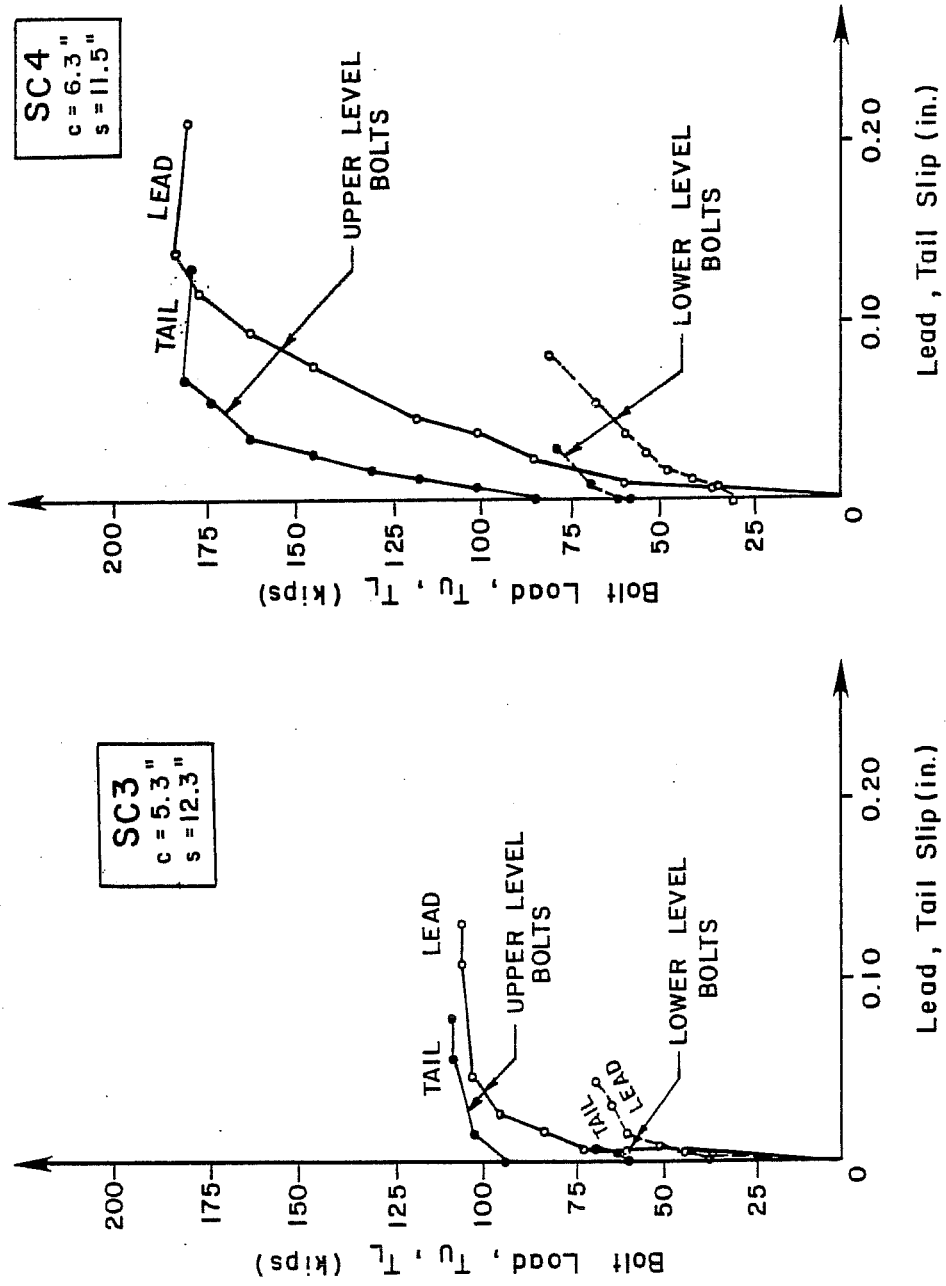

Fig. 4.6 Load-slip curves, SC3 and SC4

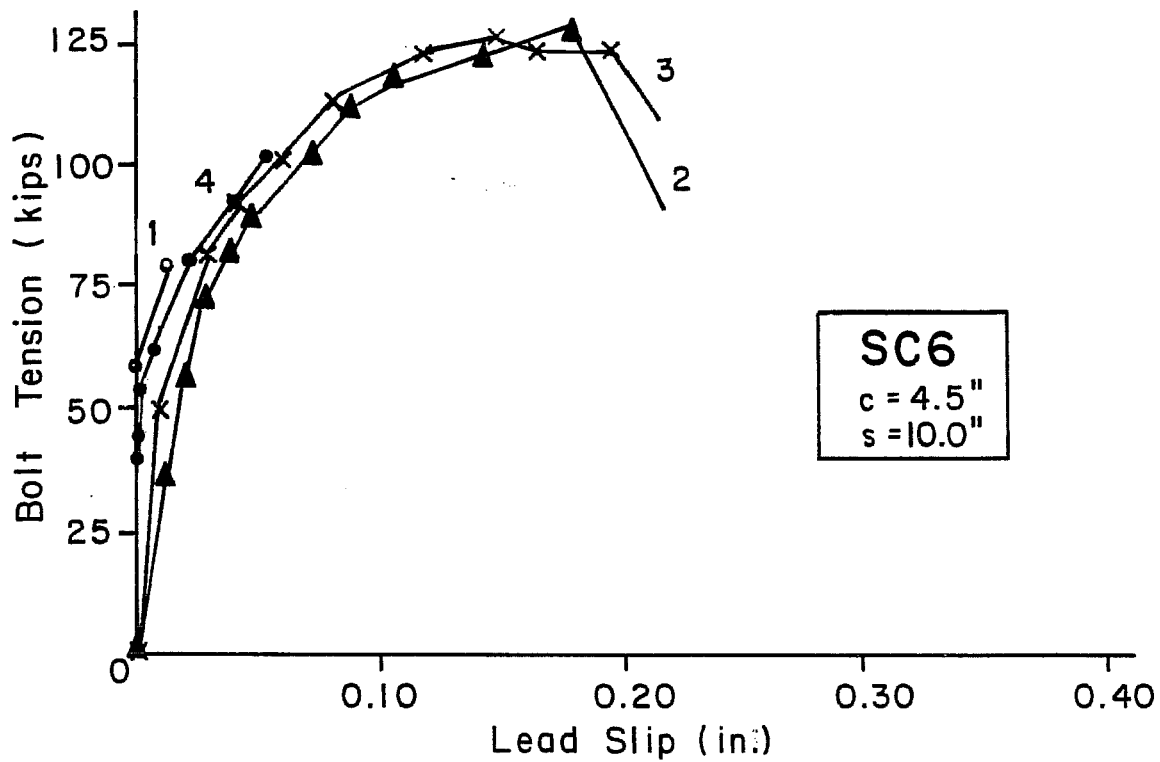
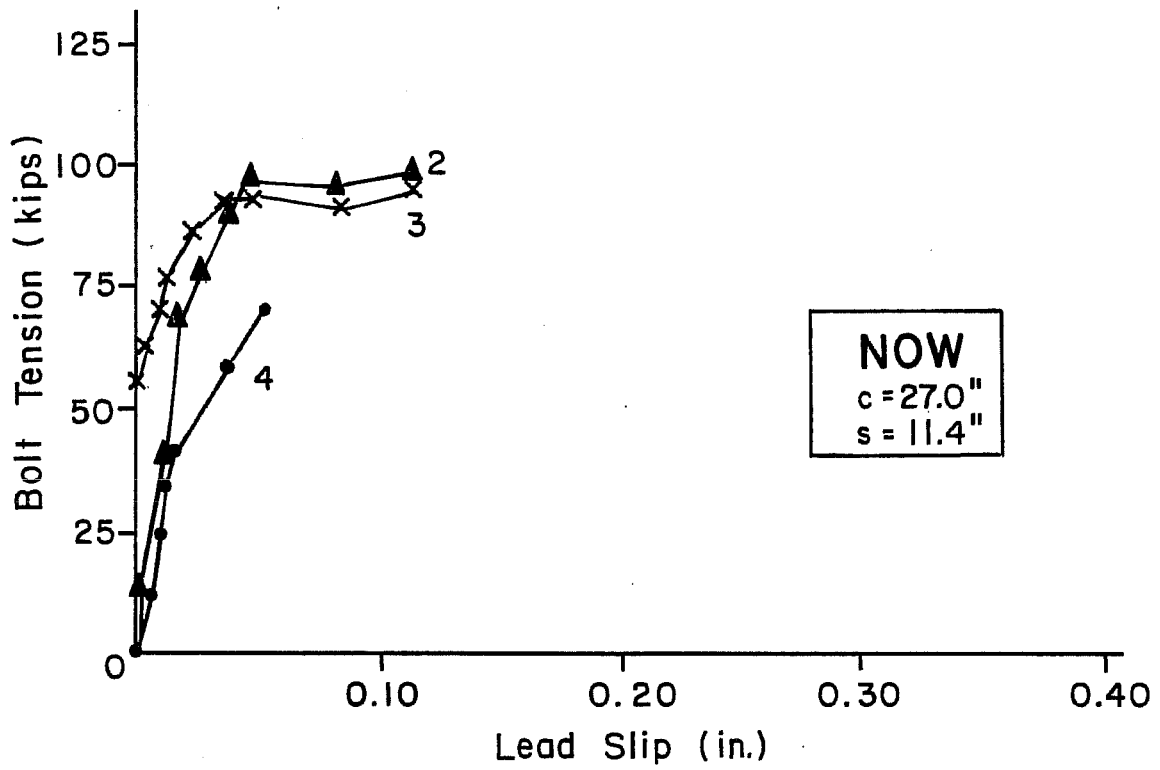

Fig. 4.7 Load-slip curves, NOW and SC6

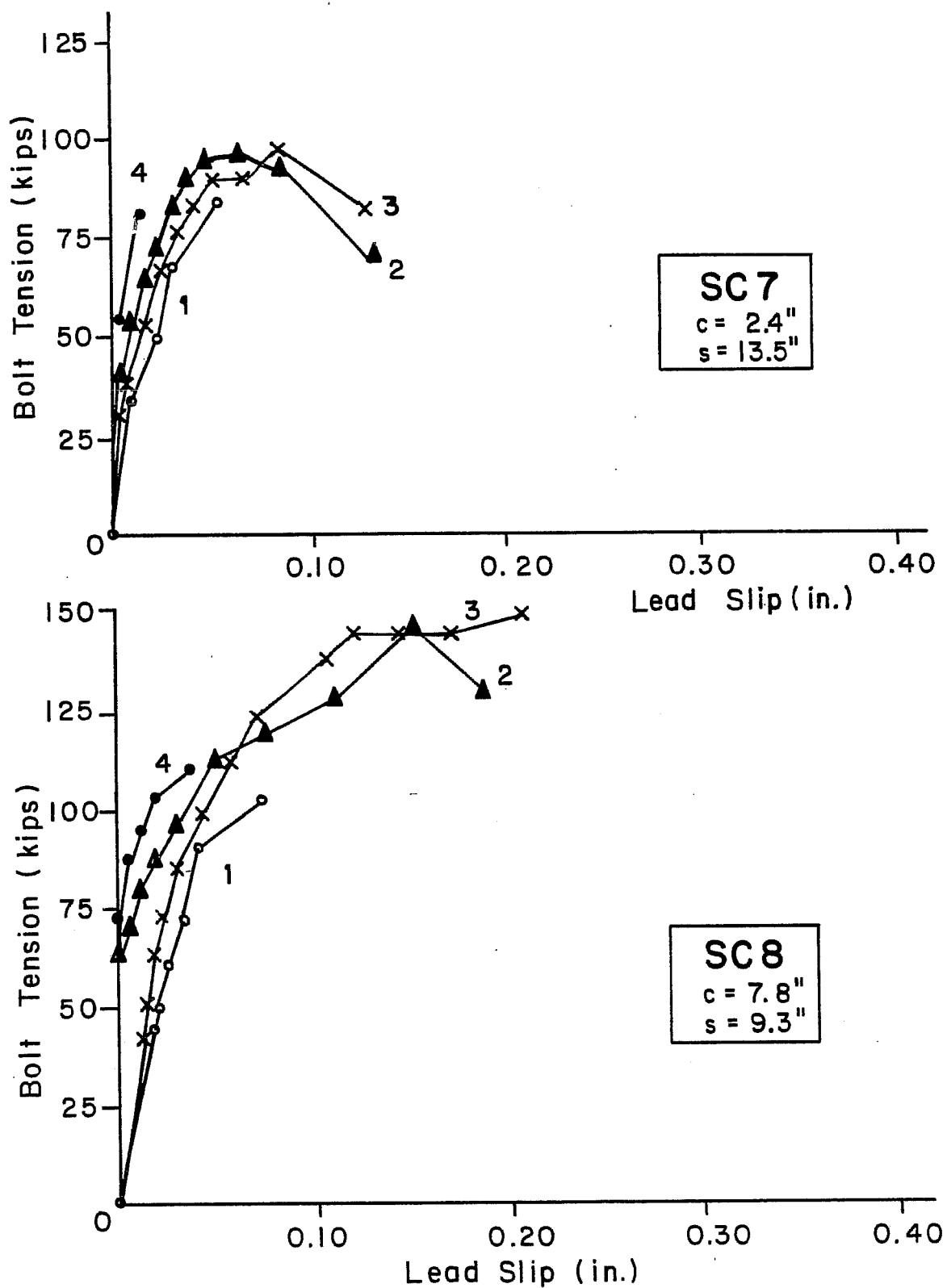

Fig. 4.8 Load-slip curves, SC7 and SC8

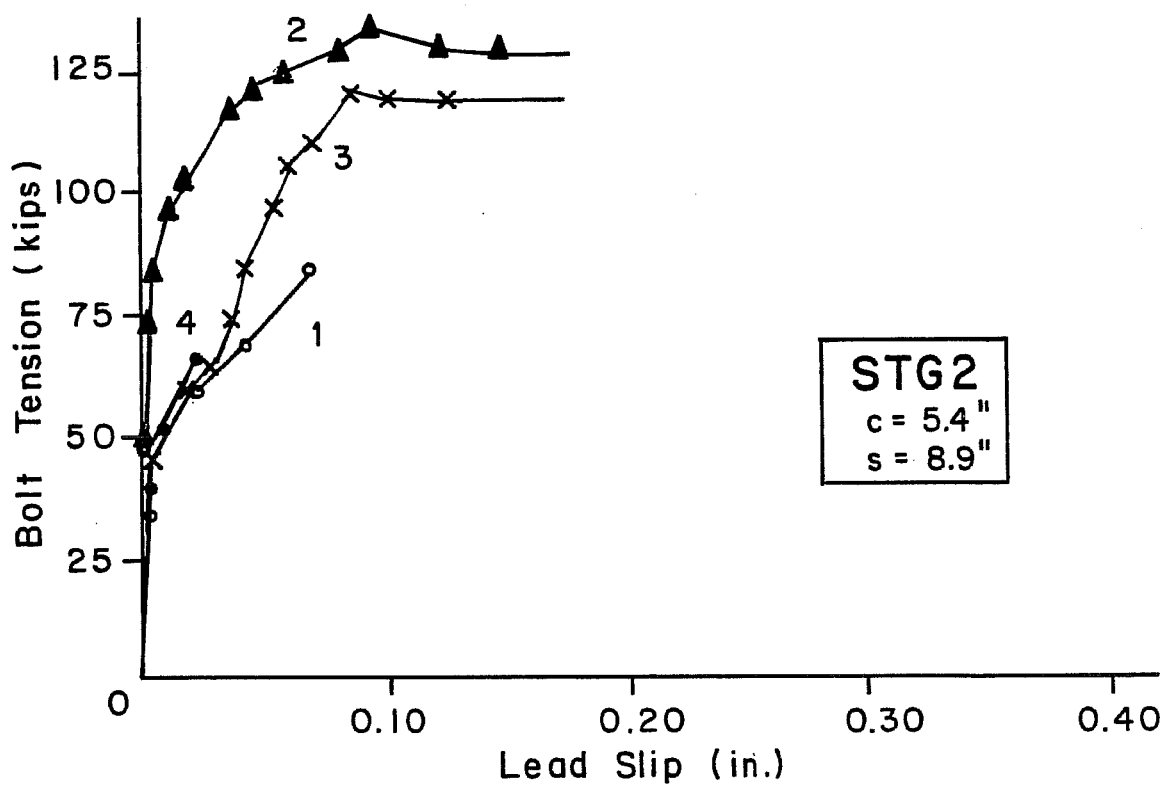
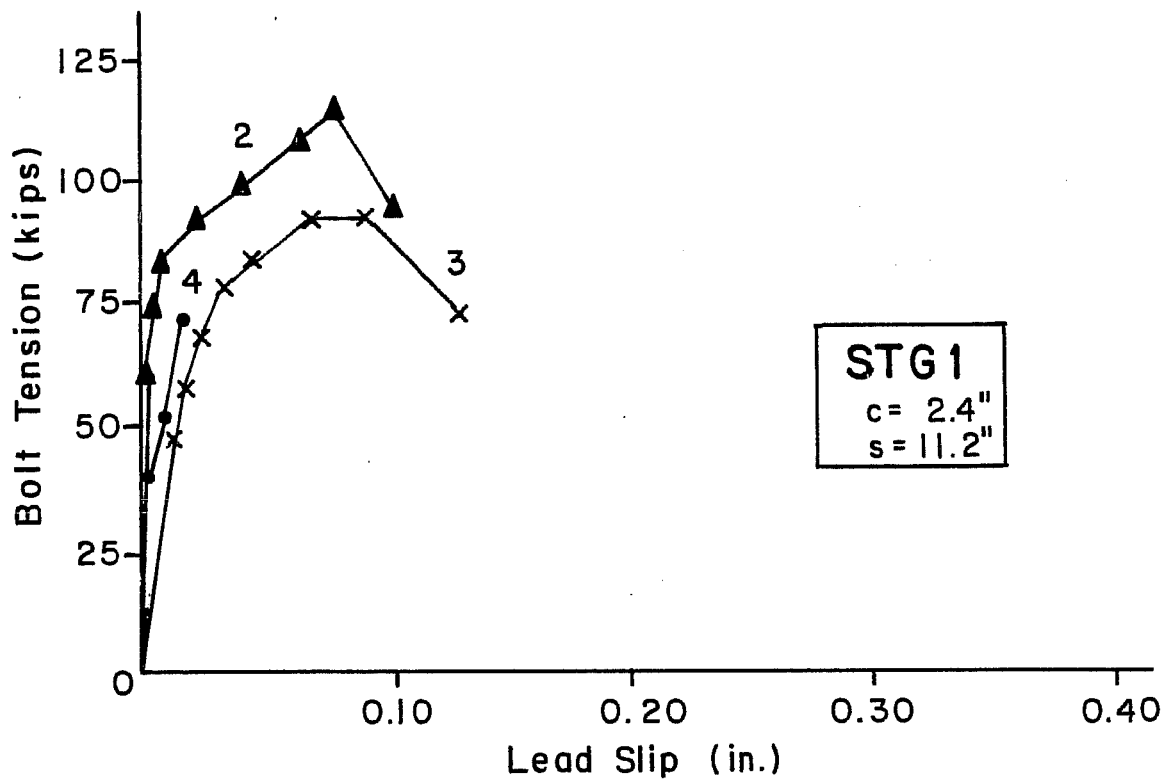

Fig. 4.9 Load-slip curves, STG1 and STG2

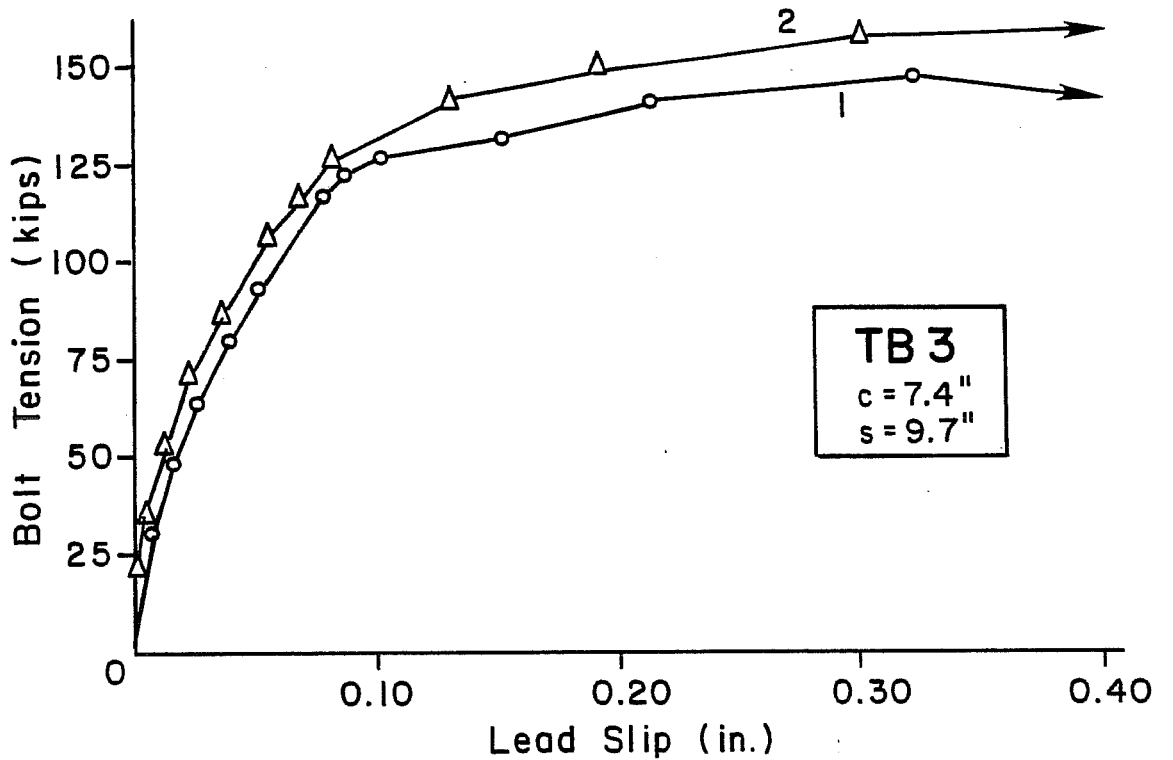
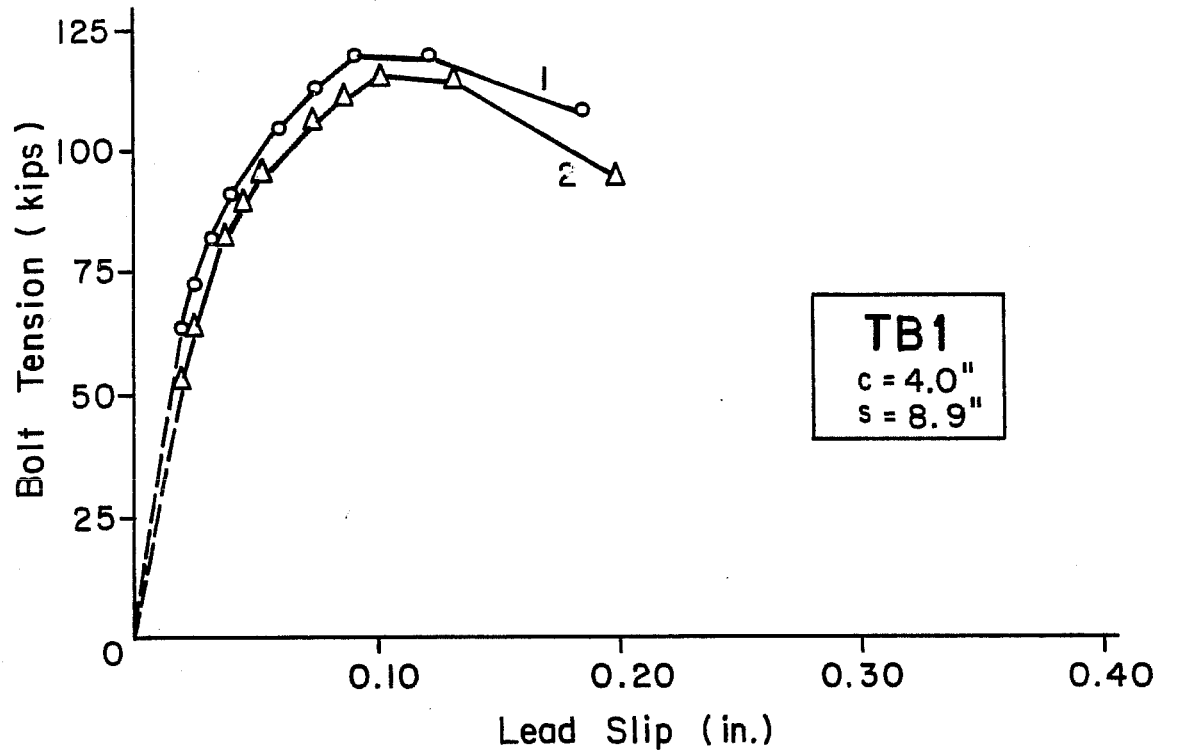

Fig. 4.10 Load-slip curves, TB1 and TB3

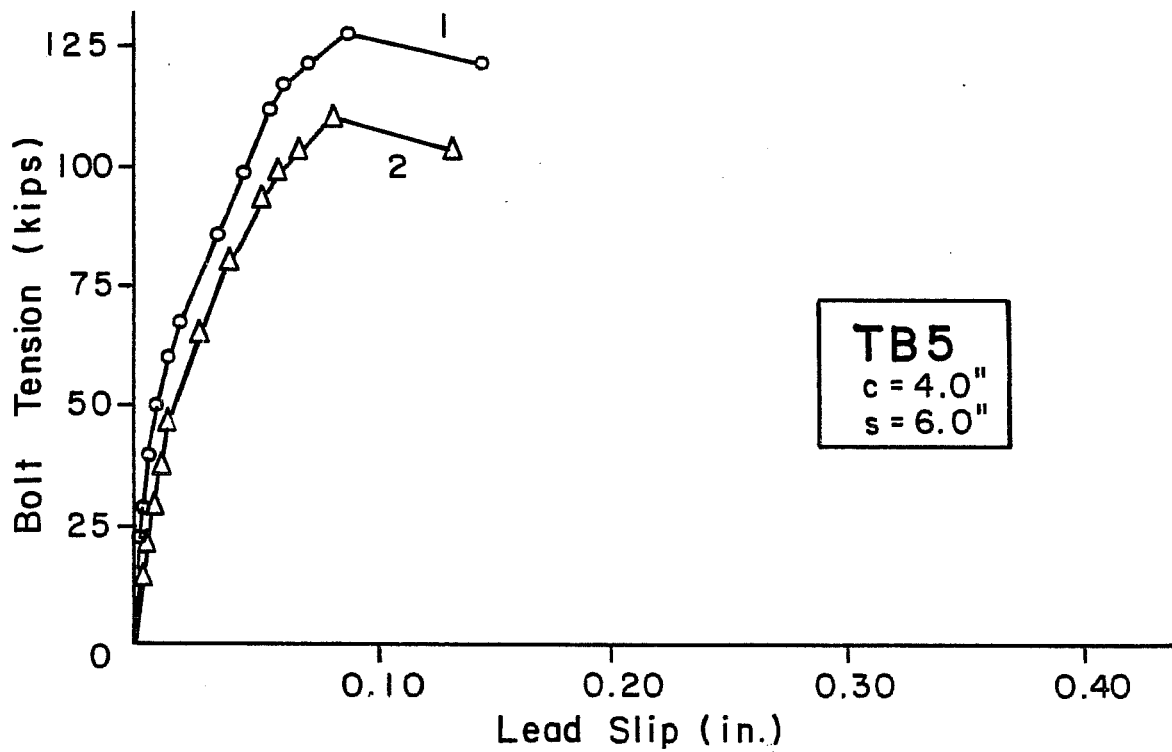
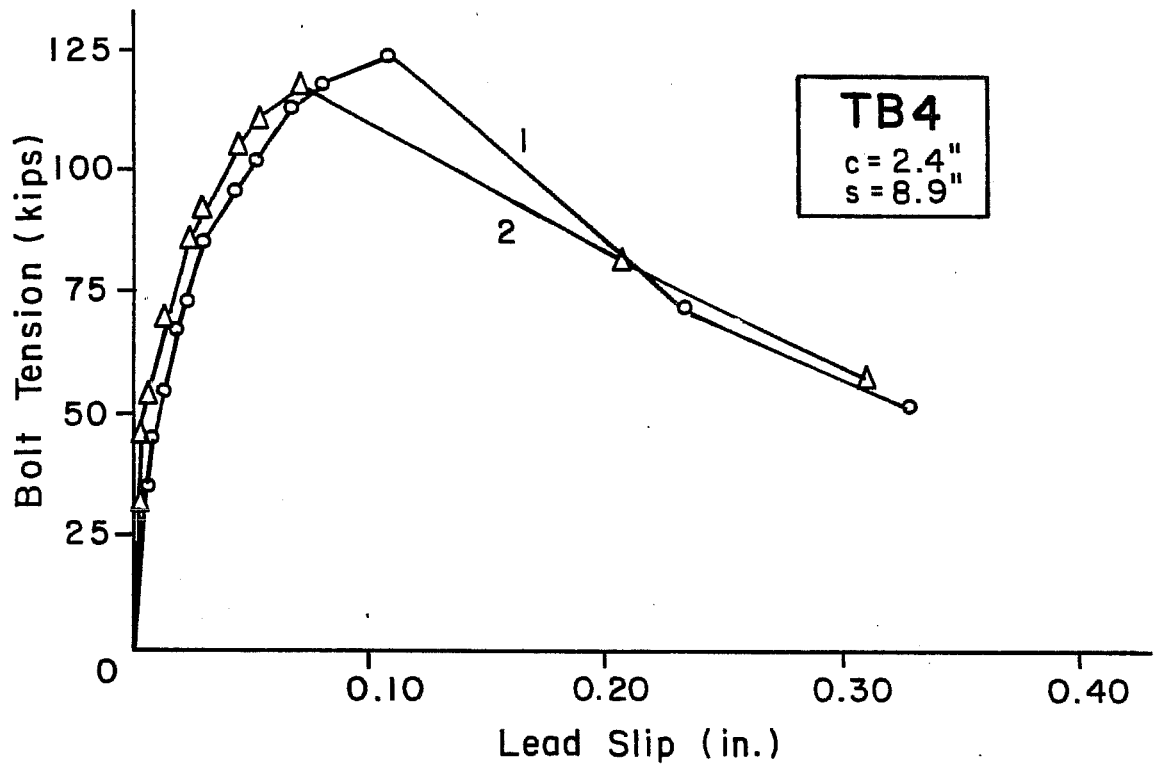

Fig. 4.11 Load-slip curves, TB4 and TB5

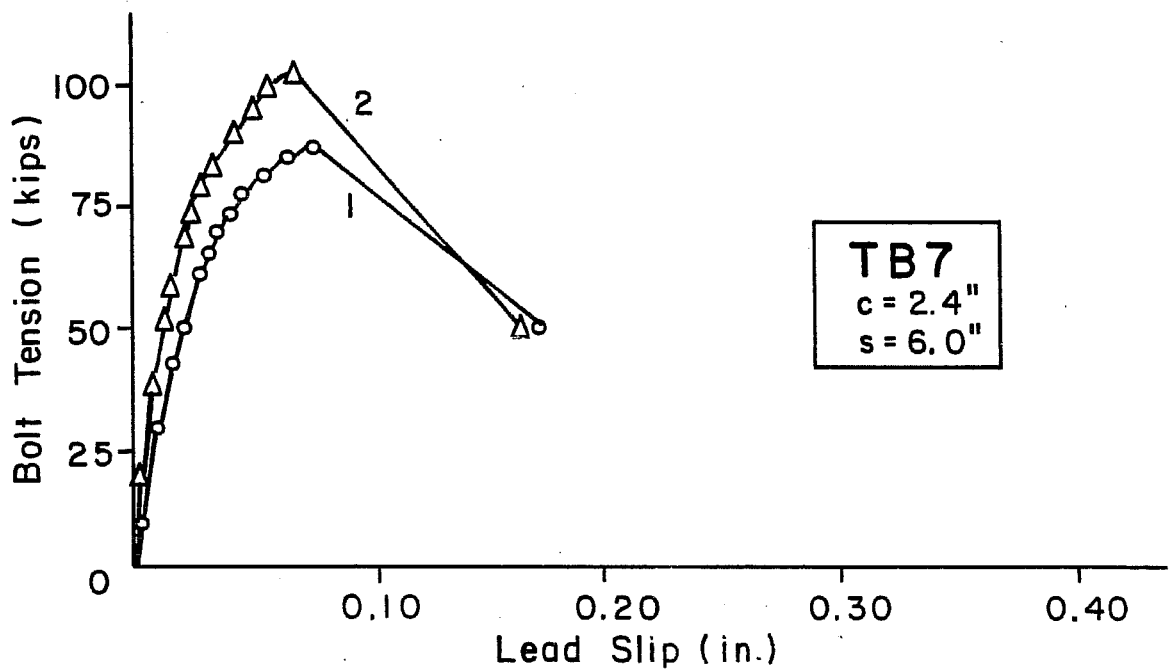
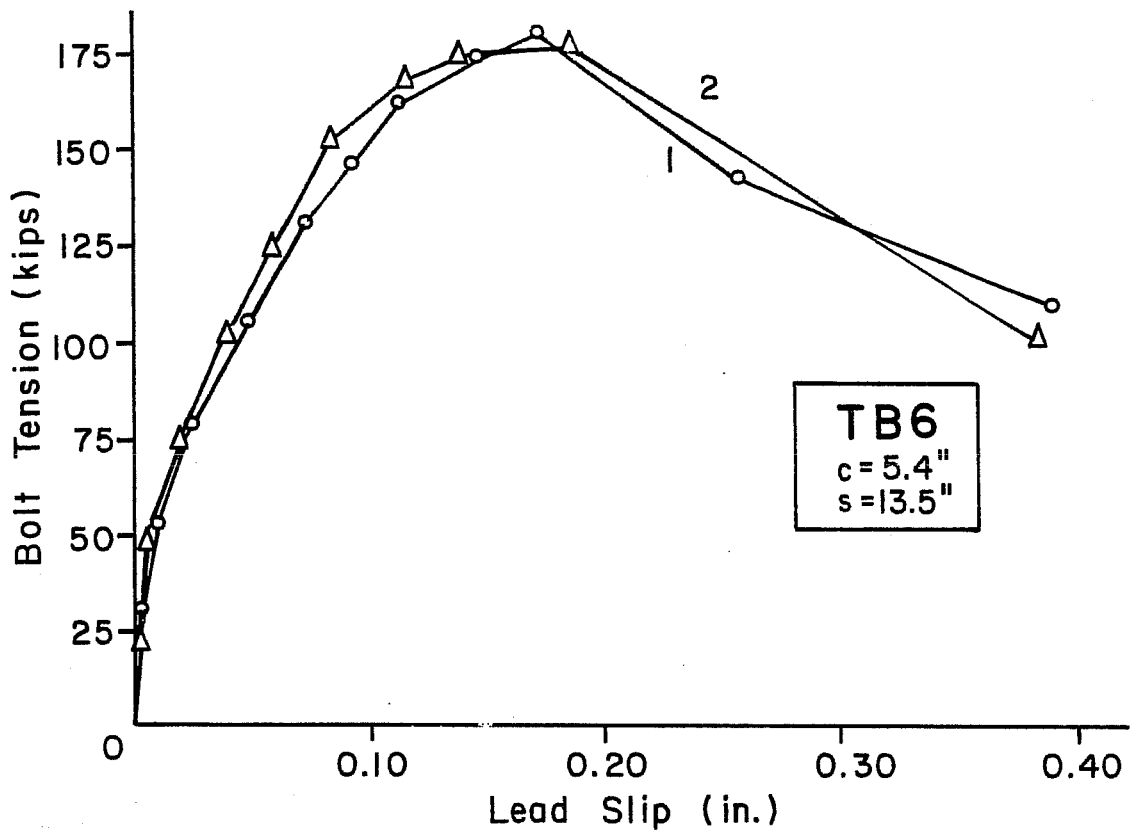

Fig. 4.12 Load-slip curves, TB6 and TB7

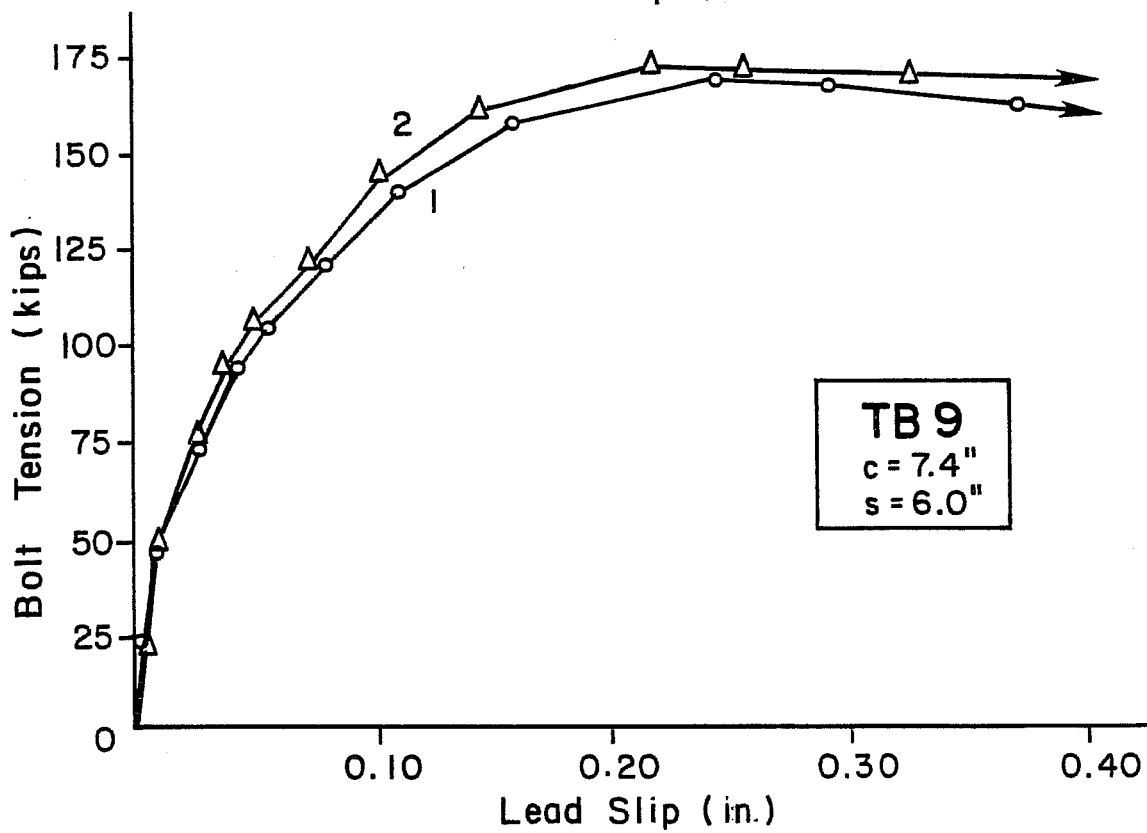
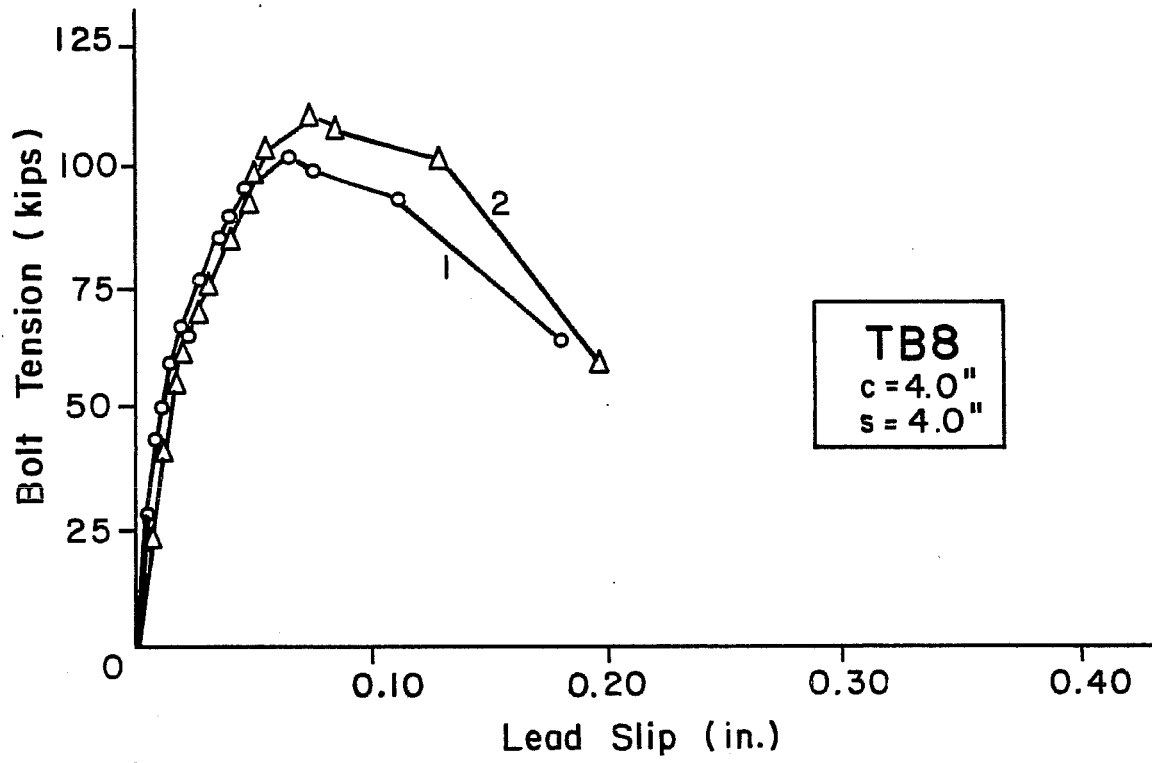

Fig. 4.13 Load-slip curves, TB8 and TB9

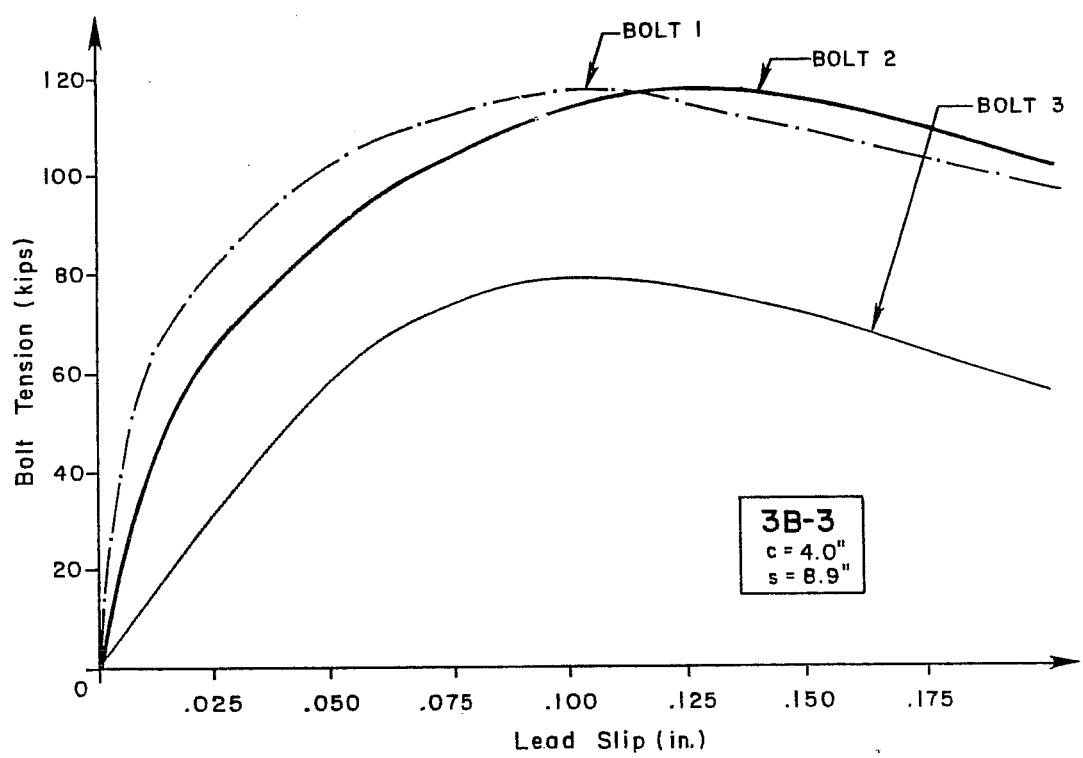
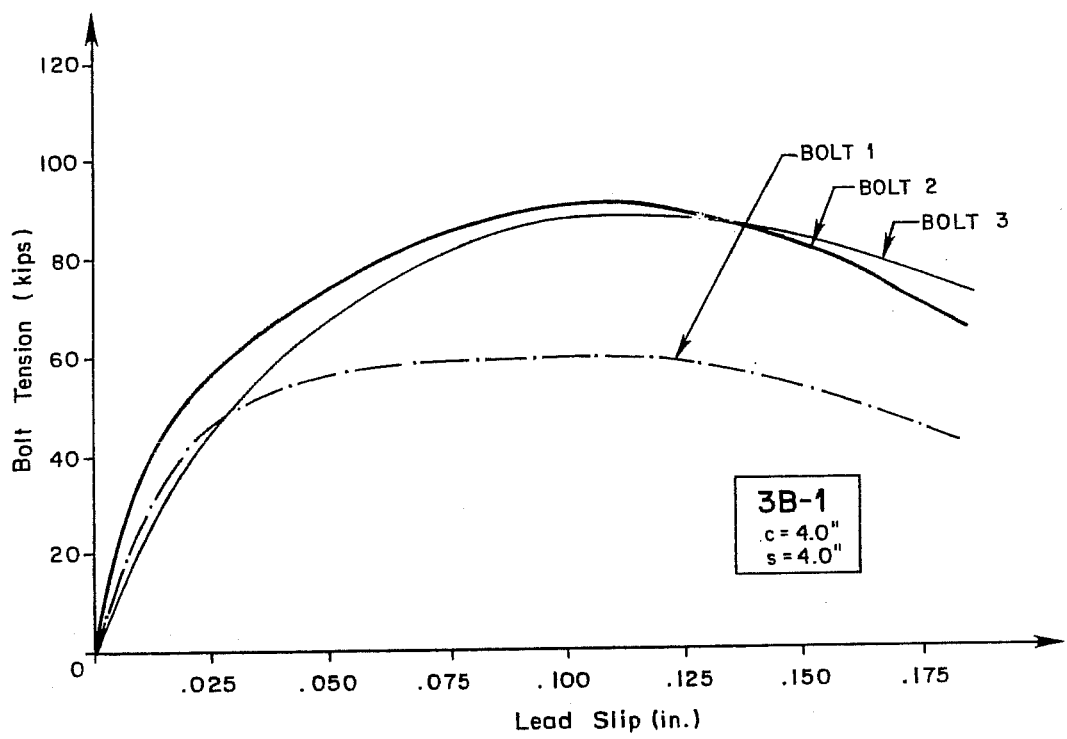

Fig. 4.14 Load-slip curves, 3B-1 and 3B-3

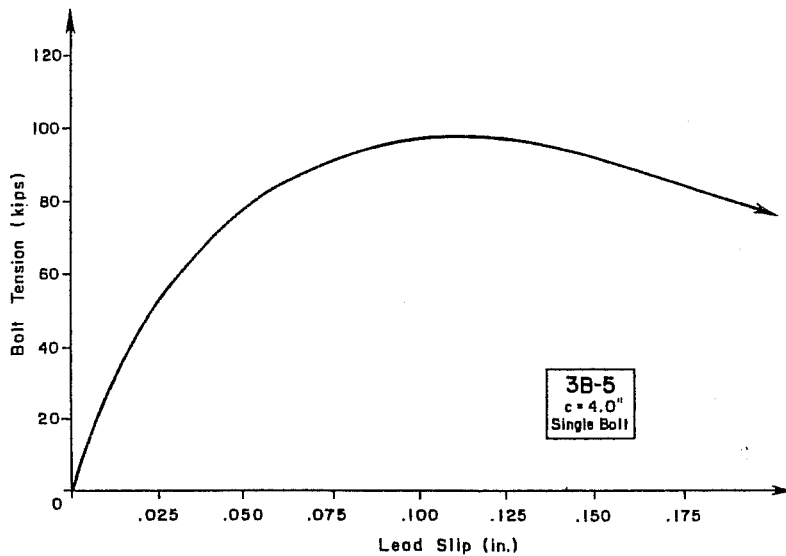
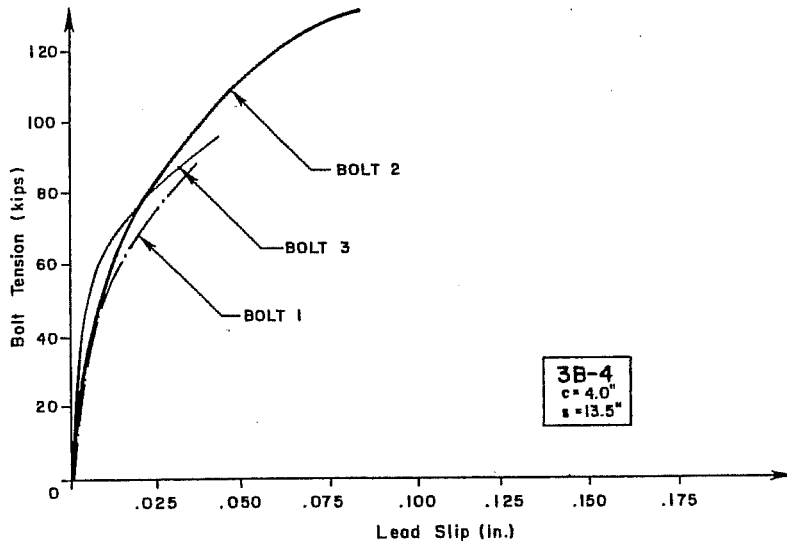
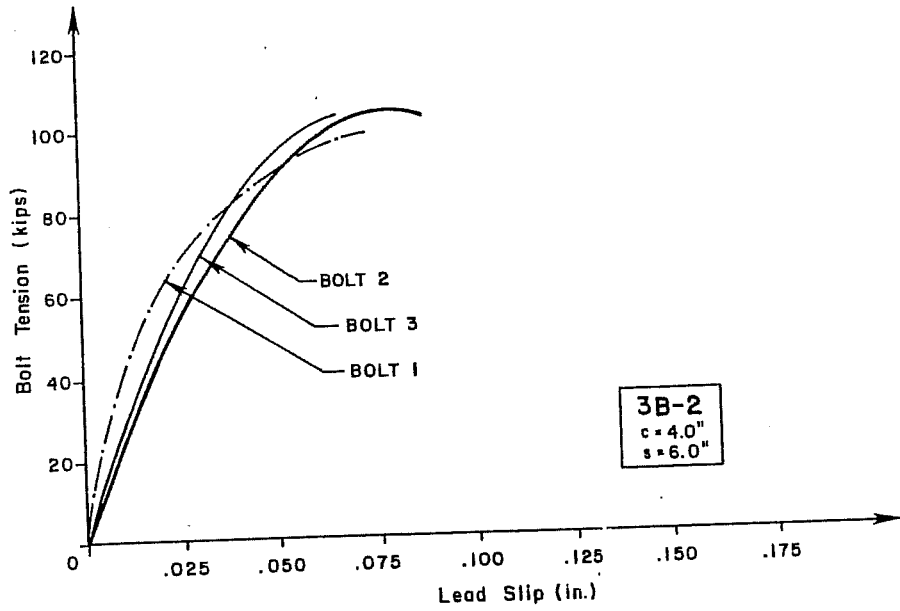

Fig. 4.15 Load-slip curves, 3B-2, 3B-4 and 3B-5

the two-bolt groups and in the upper and lower levels of the four-bolt groups of each test was very similar.

With respect to both the stiffness and the strength of each anchor bolts group, it is hard to compare the response because of variations in concrete strength. Comparisons can be drawn, however, with respect to the amount of slip which had occurred when ultimate bolt tension was reached. Bolt groups with small clear cover reached ultimate at an average slip of less than 0.10 in. On the other hand, bolts with a cover of 7.4 in. reached ultimate at average lead slips in excess of 0.2 in. In tests with large cover, the bond-slip curve was nearly level before ultimate was reached and remained fairly level beyond this point. In tests with smaller cover, the load-slip curve flattened just before ultimate was reached and dropped abruptly after failure. Here it is important to note that in all of the tests failure was governed by the concrete not by yielding of the anchor bolts; therefore, the seemingly ductile behavior of the tests with large cover was clearly not associated with bolt yielding.

4.4 Crack Patterns

For all of the bolt groups tested, the concrete cover failed by wedge-splitting, as described by Hasselwander et al. [1] for individual bolts. In this failure mode the concrete cover is split into distinct blocks by the wedging action of a cone of crushed and compacted concrete which forms in front of the anchorage device, as shown in Figs. 4.16 and 4.17. The distinguishing feature of a wedge-splitting failure for an individual bolt is diagonal cracks which start just in front of the anchorage device on the bolt centerline and extend toward the front and sides of the specimen.

From observations in this series of tests, as well as Hasselwander's tests, it can be concluded that for two bolts spaced closely together, interaction between splitting forces around the anchorage devices prevents the individual wedge-splitting mechanisms from forming completely. This is evidenced by a general absence of cracking in the region between the bolts for groups with very close spacing. For groups with relatively larger spacing, more cracking is observed between the bolts as less interaction between the splitting forces occurs. However, test results seem to indicate that any interaction between bolts in a group is sufficient to cause a significant strength reduction compared to bolts acting independently.

4.4.1 Four-Bolt Groups. In the four-bolt tests, cracking prior to failure was associated almost entirely with bolts 2 and 3; only limited (initial) cracking across bolts 1 and 4 above the nut and washers was observed in several tests. It seems reasonable to assume that interaction did not occur between top and bottom level bolts. Initially, a crack appeared across the bolts on top of the washers (Fig. 4.18). Close to, or at, the group capacity, major cracks emerged near

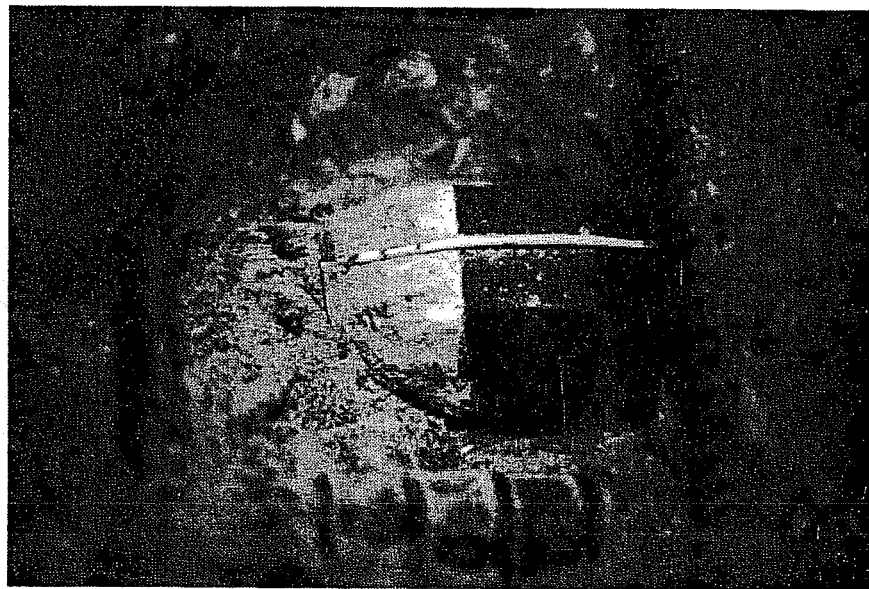
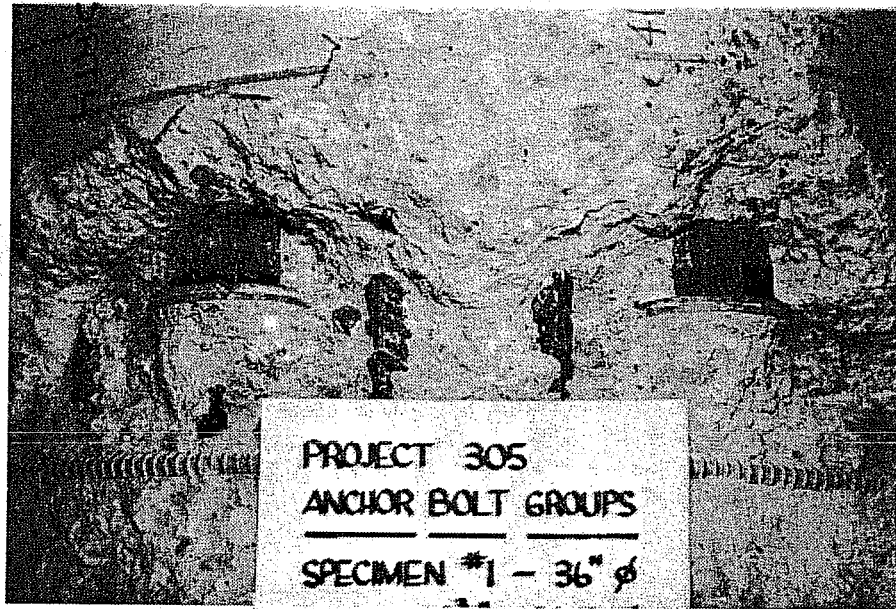

Fig. 4.16 Cone of crushed and compacted concrete
in front of anchorage device

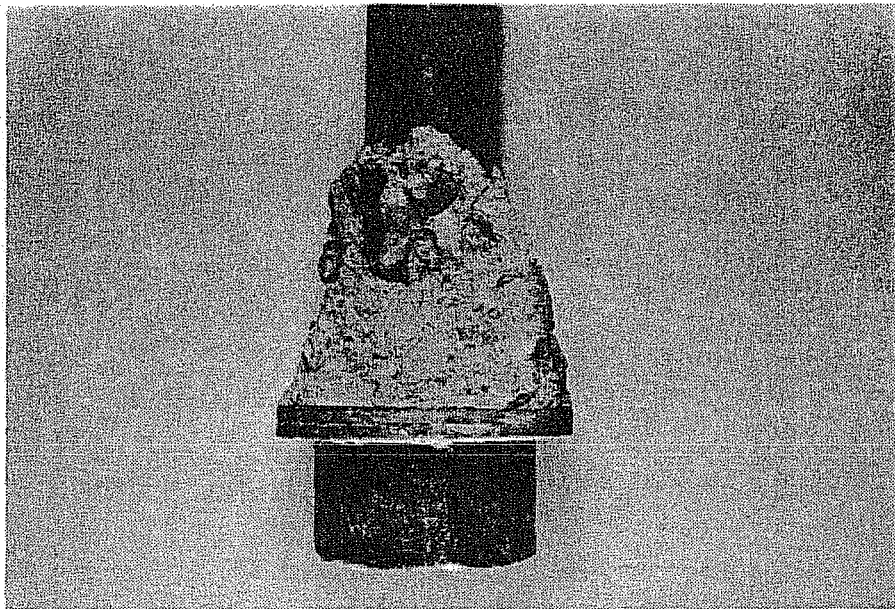
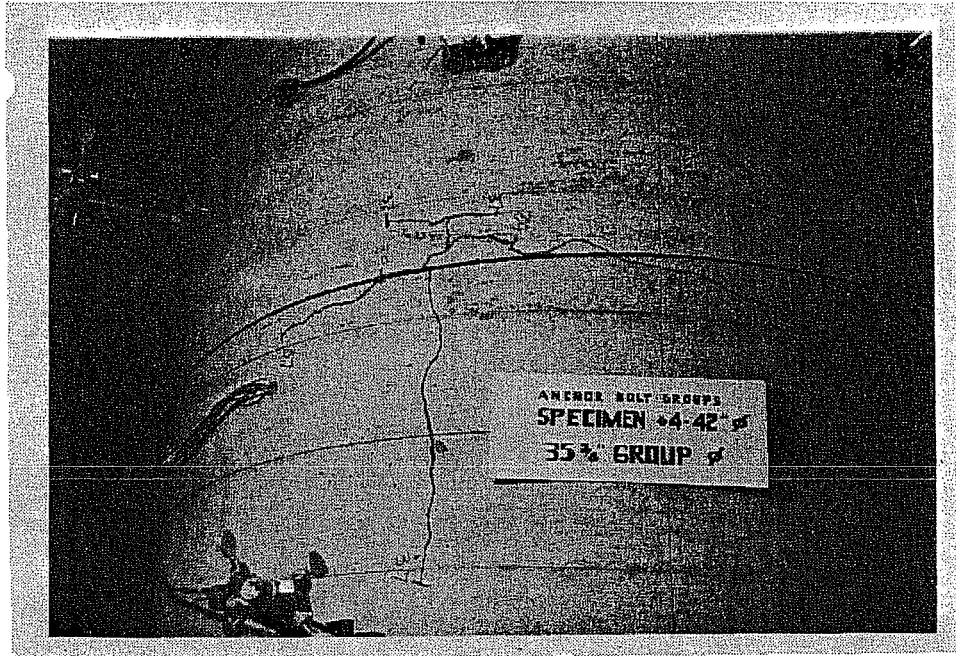
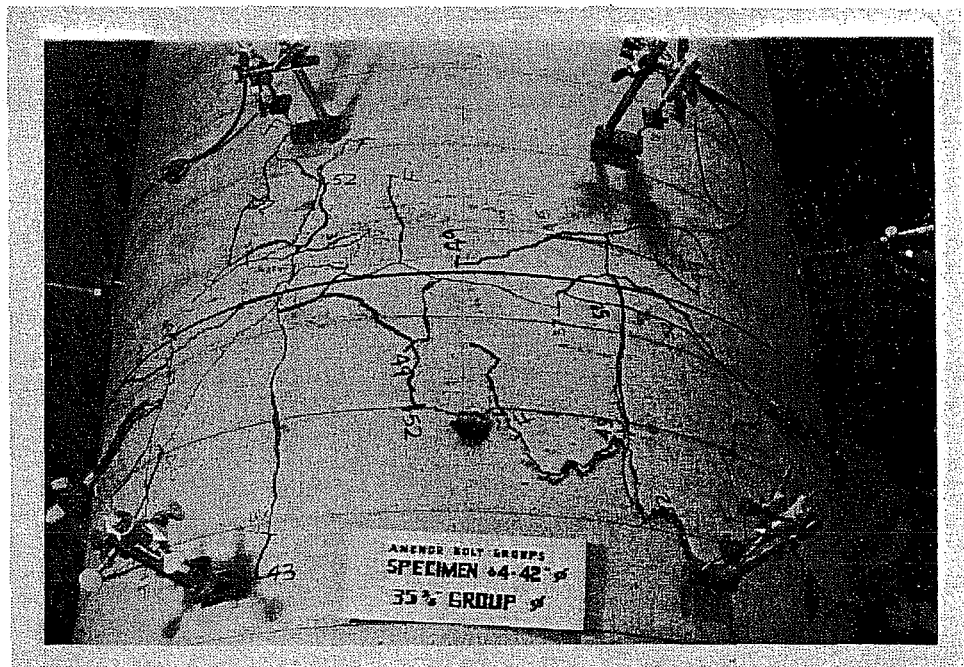

Fig. 4.17 Anchor bolts after removal from test specimen showing cone of compacted concrete



Initial cracking



At failure

Fig. 4.18 Crack pattern, SC7

the anchorage end and extended forward along the sides and top of the anchor bolts completing failure surfaces from the bolt to the exterior of the specimen. The failure surfaces intersected at the zone between the two top bolts. The concrete cover on top of the bolts was observed to split and uplift as the bolts failed (Fig. 4.19). There appeared to be less interaction between bolts and less intersection of crack patterns in the specimens with staggered bolts (Fig. 4.20).

4.4.2 Two-Bolt Groups. Figure 4.21 shows the development of cracks for test TB5. Initially, a transverse crack was observed to form parallel to and near the washer of the anchorage device. As load increased, diagonal cracks extended from the anchorage region toward the front and sides of the specimen. For most of the tests, uplift of the concrete cover (Fig. 4.19) near the anchorage device was observed at failure. In general, two separate uplifted zones appeared over the bolts with large spacing, while only one zone appeared where spacing was small.

Figure 4.22 shows cracking at ultimate for tests with small or with large cover. Cracking was significantly more extensive over the entire surface for the test with large cover than in the tests with shallow cover. In the tests with shallow cover, the applied load dropped abruptly after the cover uplifted. With large cover, the ultimate load was maintained as slip increased. No distinct region of concrete cover was observed to uplift.

4.4.3 Three-Bolt Groups. In the three-bolt groups having relatively close spacing, cracking of the concrete cover between the bolts was minimal. With large spacing of the bolts more extensive cracking was observed as the individual failure mechanisms were formed. Crack patterns for tests 3B-2 and 3B-3 are shown in Figs. 4.23 and 4.24. The pattern is very similar to that of the 2- and 4-bolt groups anchored in circular piers.

4.5 Effect of Transverse Reinforcement, Spirals, Ties

The location of the transverse reinforcement relative to the anchor bolts varied in each test. Cover on the spirals and ties was constant while cover to the bolt varied. Therefore, direct comparisons of the influence of transverse reinforcement are not possible and only general trends will be discussed.

Figure 4.25 shows spiral strains for test TB5 (small cover on bolts). Figure 4.26 (large cover on bolts) shows strains for test TB9. Spiral strain and bolt lead stress are plotted against tail slip. Spiral strain, rather than stress, is plotted because the actual yield stress of the spiral in the specimen could not be determined. (although the spiral material may have had a nominal yield strength of 40 ksi initially, it was work-hardened during fabrication and it would have

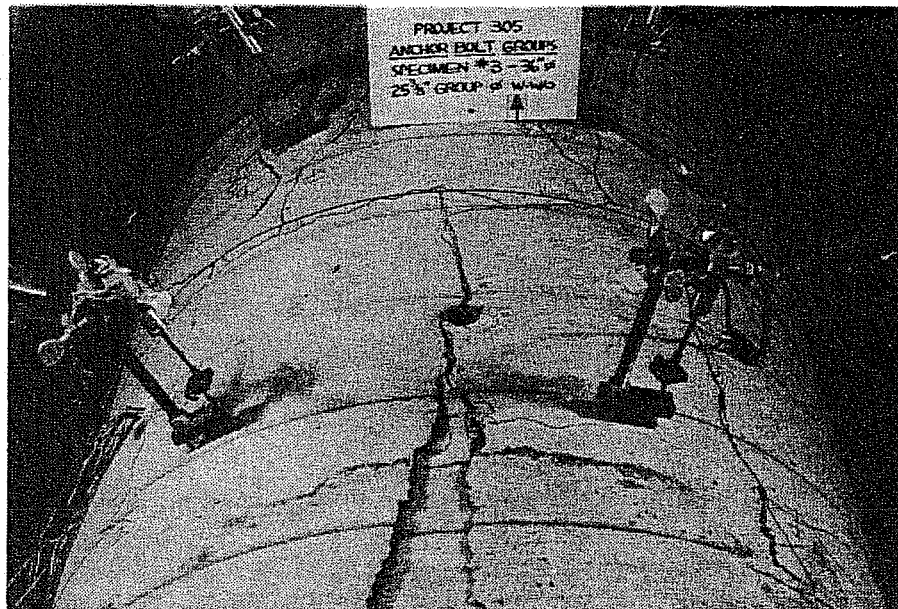
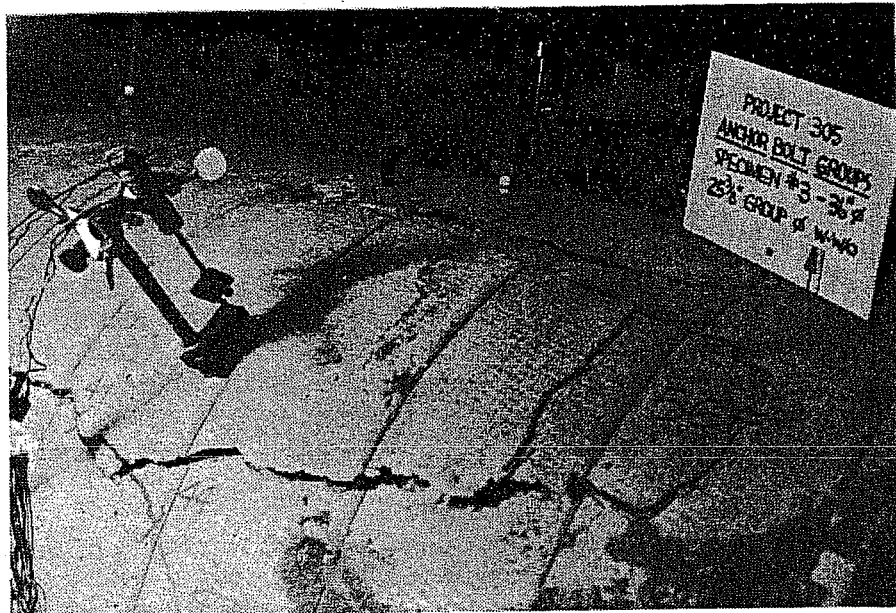

Fig. 4.19 Splitting and uplift of cover, SC6

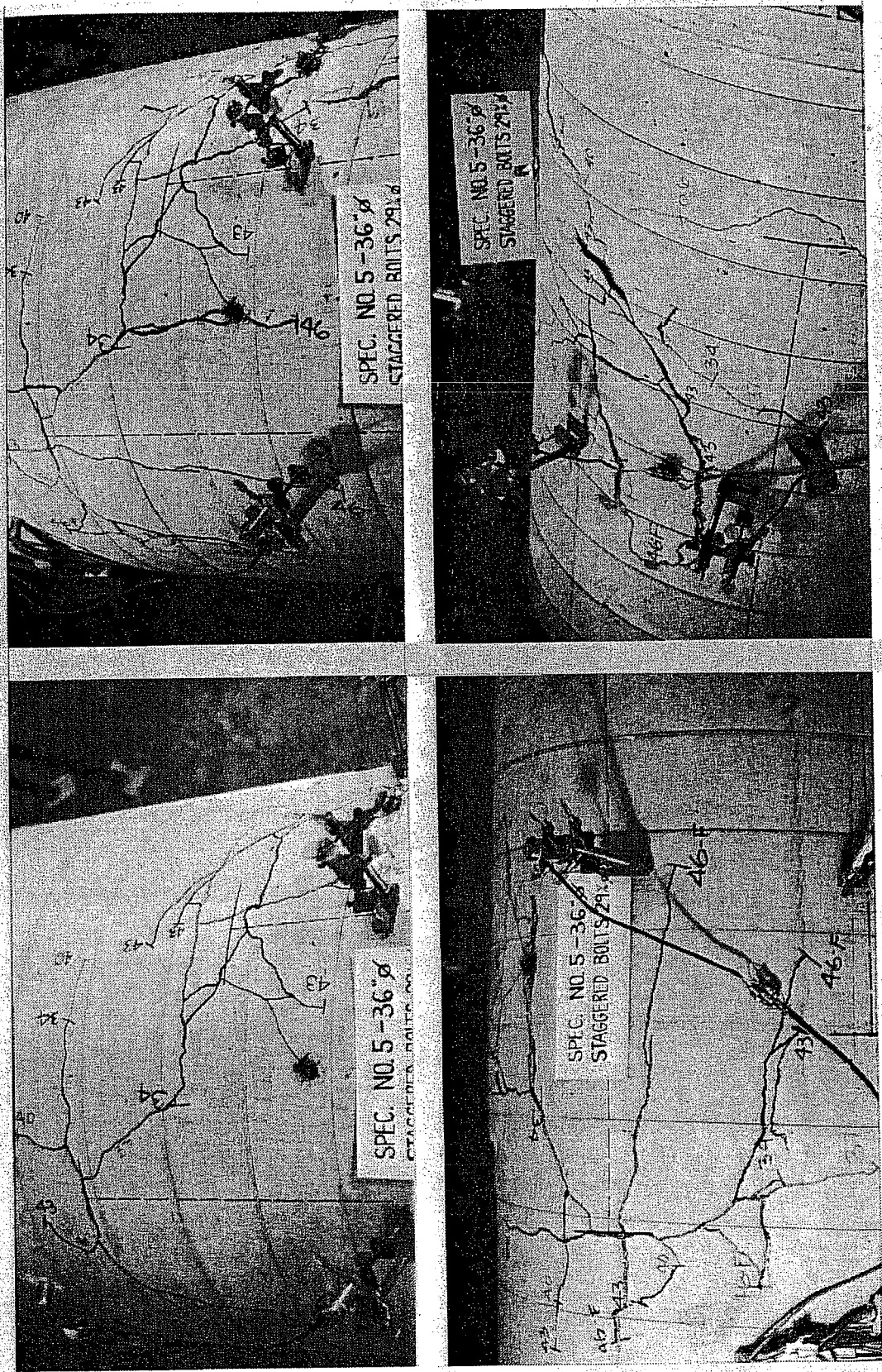
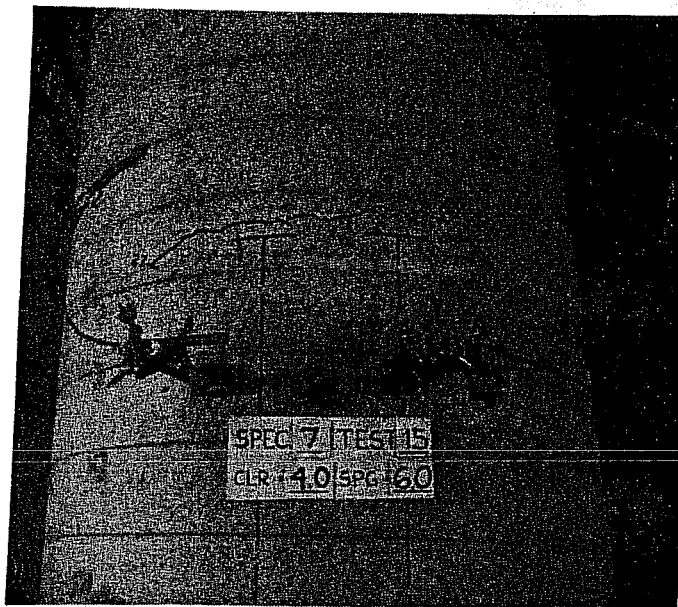
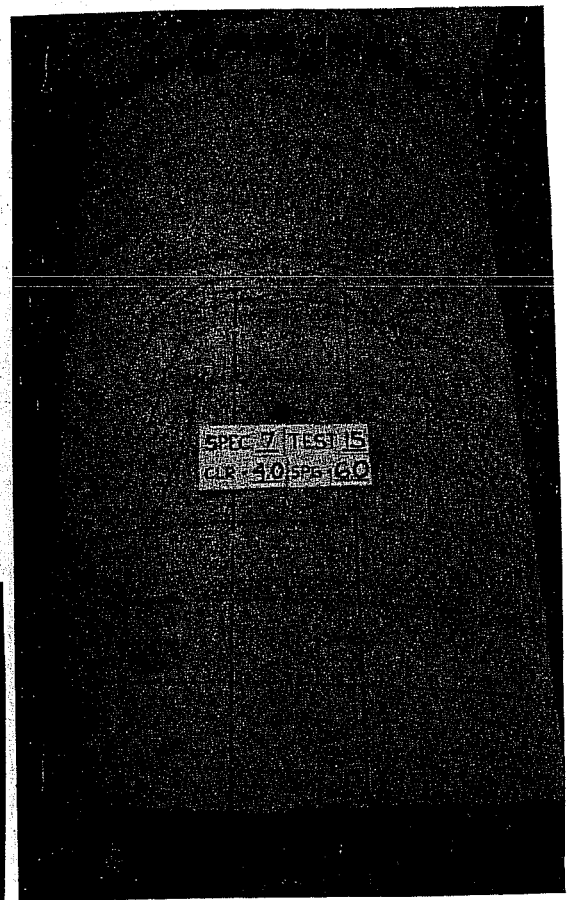

Fig. 4.20 Crack patterns, staggered bolts: STG1



(a) Initial cracking



(c) Ultimate

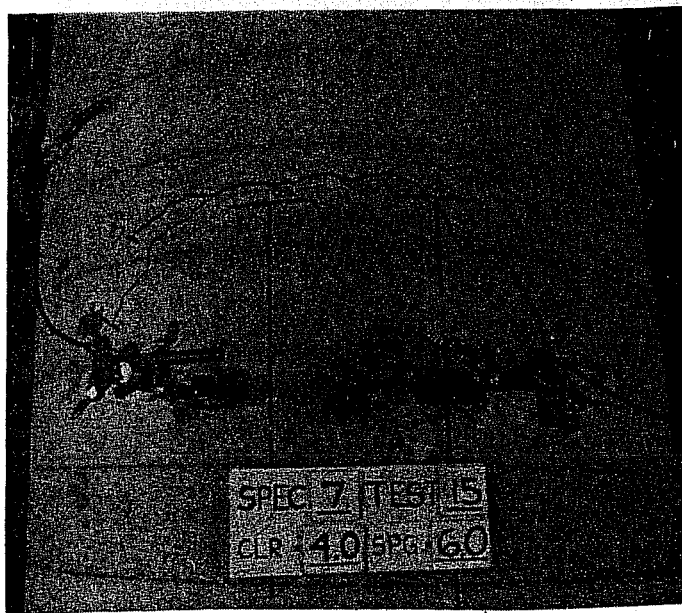

(b) Crack propagation

Fig. 4.21 Crack development: test TB5

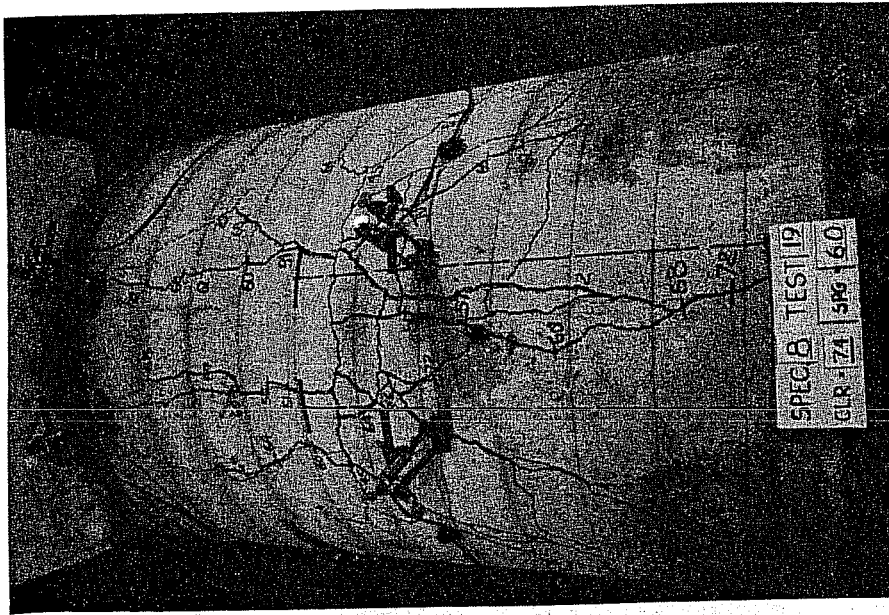

(a) Small cover, TB4

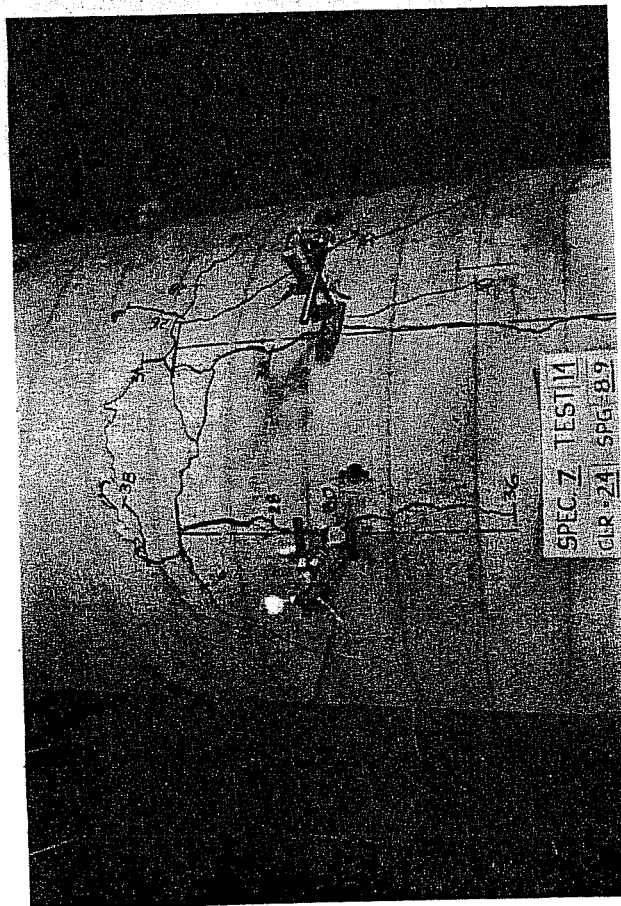

(b) Large cover, TB9

Fig. 4.22 Effect of cover on cracking at ultimate

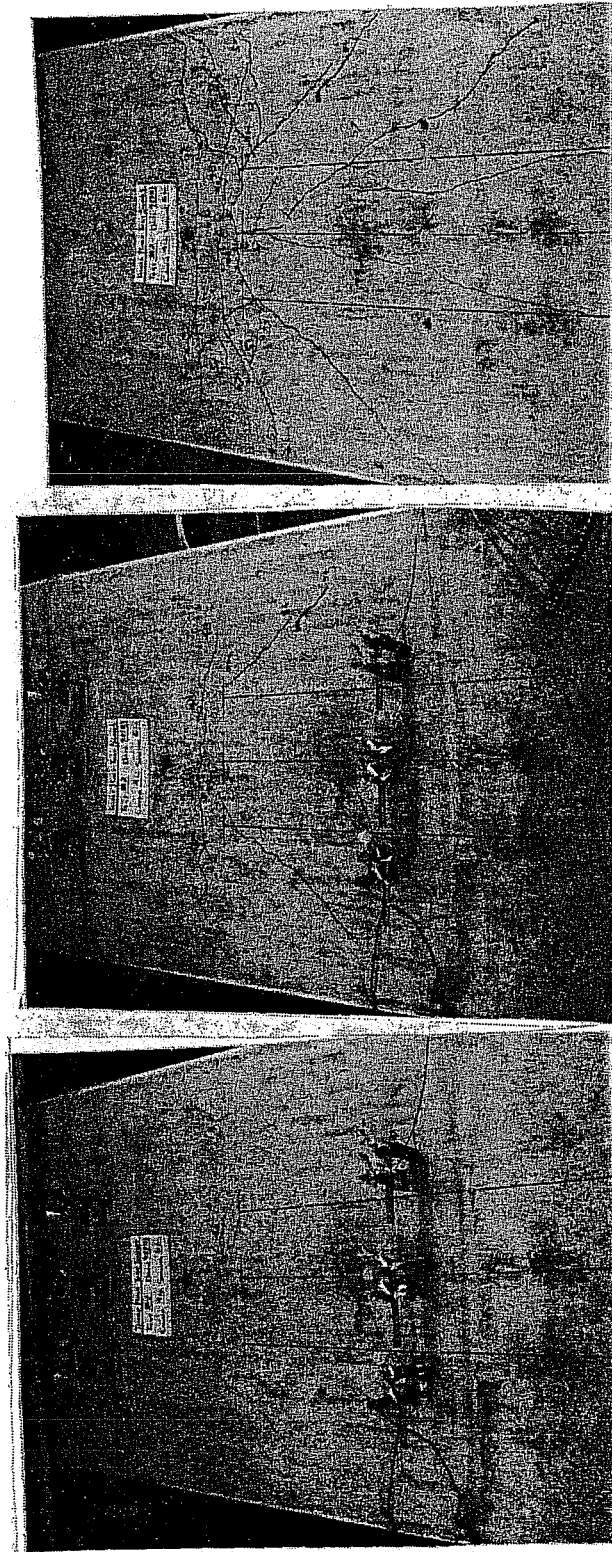

(a) Initial cracking

(b) Crack development

(c) Cracking at ultimate

Fig. 4.23 Cracking, 3-bolt group, 3B-2

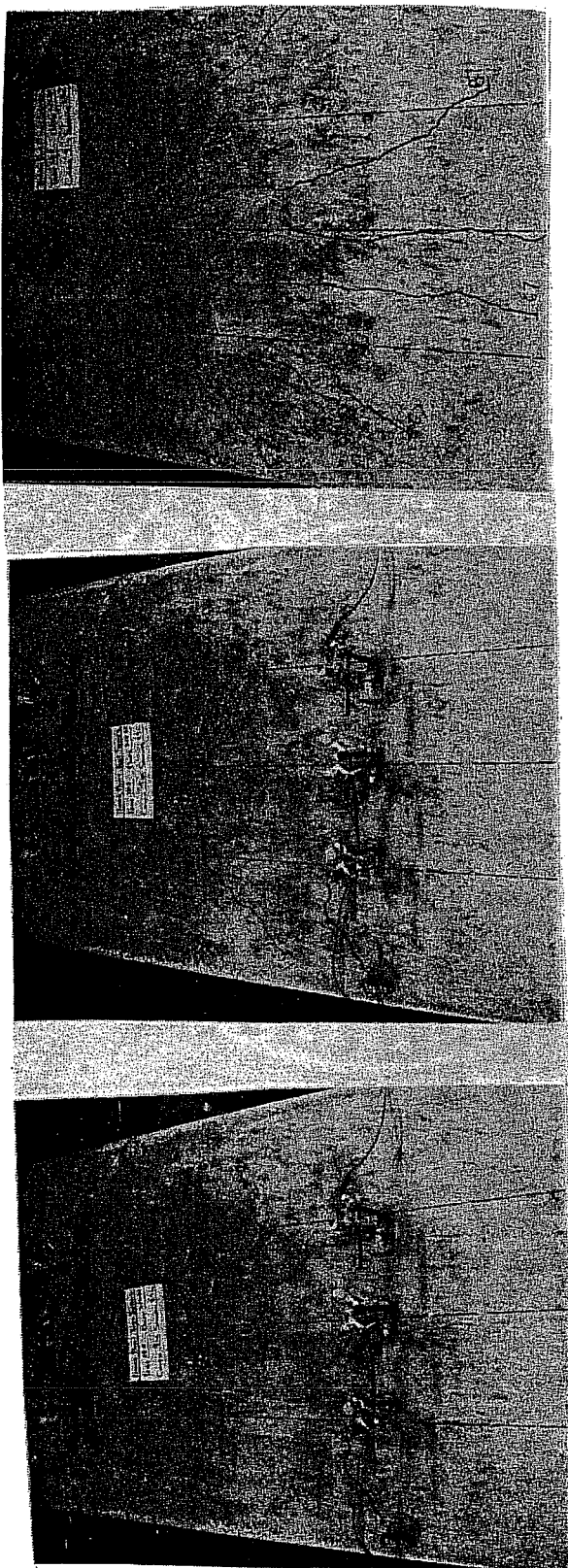

(a) Initial cracking

(b) Crack development

(c) Cracking at ultimate

Fig. 4.24 Cracking, 3-bolt group, 3B-3

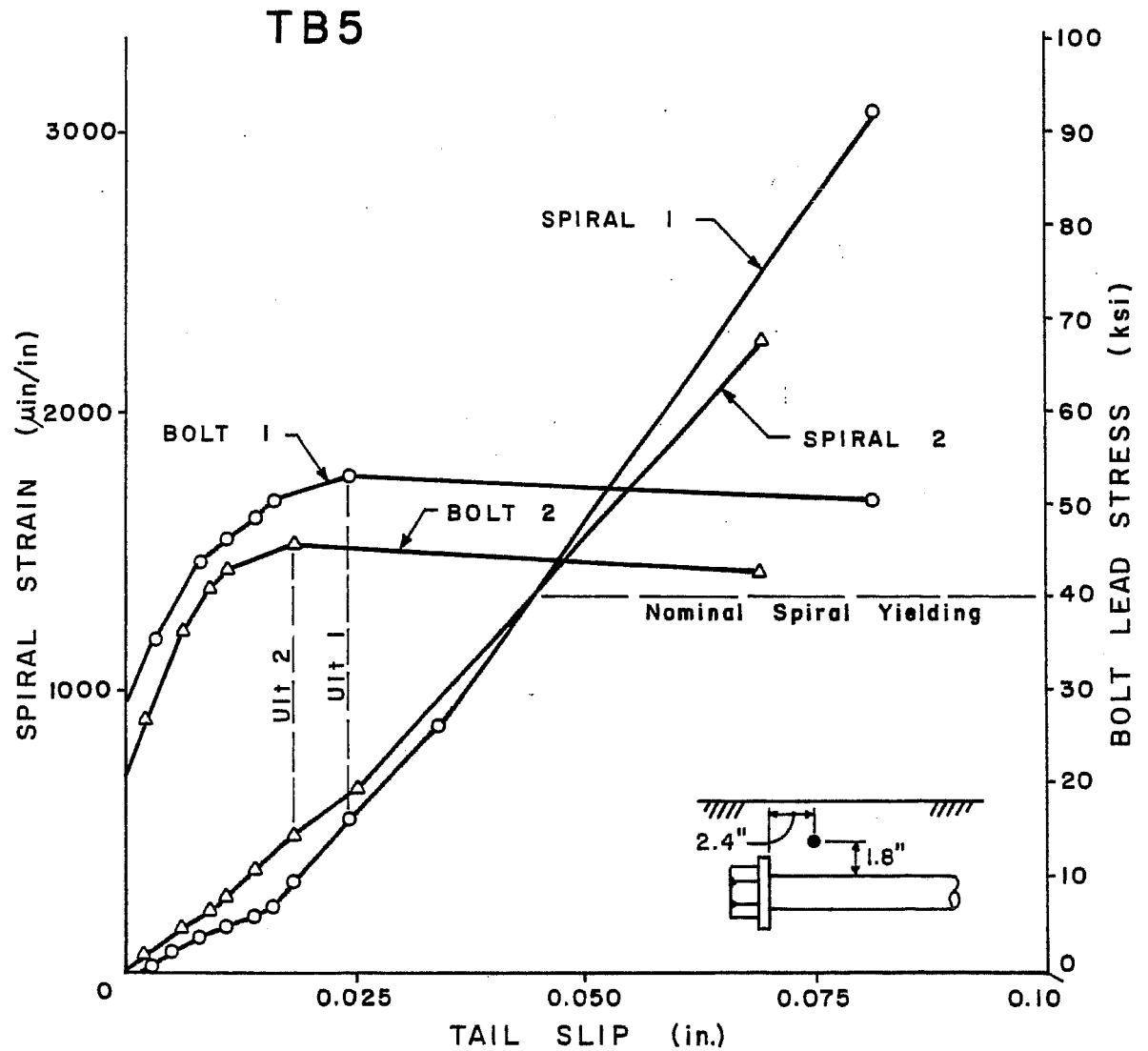

Fig. 4.25 Strains in spiral reinforcement, TB5

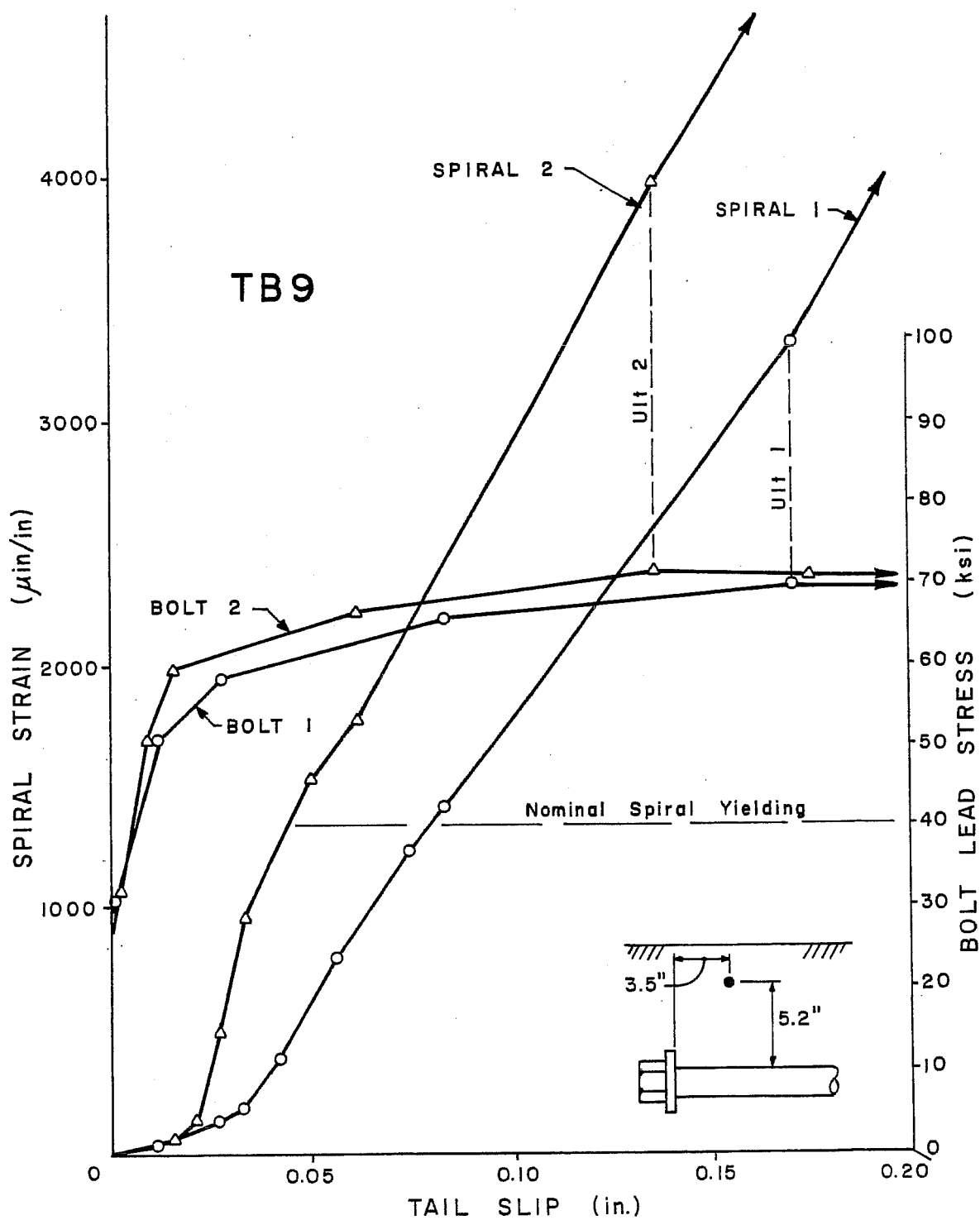

Fig. 4.26 Strains in spiral reinforcement, TB9

been necessary to work-harden it further to perform a coupon test on a straight bar segment. The nominal value of yielding, 40 ksi, is indicated by a dashed horizontal line. Bolt lead stress is plotted in order to compare spiral strains to bolt performance. The point at which ultimate bolt tension was reached is shown by dashed vertical lines for each bolt.

A general trend observed in all of the tests was that the bolt stress curve was initially very steep, while spiral strains remained low. Once significant cracking had occurred, the bolt stress curve began to flatten. This was generally the point at which the spiral became effective and picked up strain. Note that in test TB5, the increase in spiral strain was more gradual than in test TB9. This indicates that a spiral located 1.8 in. above the bolt edge becomes effective at much lower load levels than a spiral located 5.2 in. above the bolt. It is interesting to note the amount of stress in the spirals at the time that ultimate bolt tension was reached. For the test with a 4.0 cover, spiral stresses were around 15 ksi at the time that the bolt capacity was reached. For the test with a 7.4 in. cover, however, the spiral yielded prior to the anchor bolt reaching ultimate. Yielding of the spiral probably accounts for the fact that the bolt stress curve was flat prior to ultimate, producing a seemingly ductile response. In the tests with shallow cover, however, an abrupt failure had already occurred before yield in the spirals could be mobilized.

In all the three-bolt tests, the bolt stress increased steadily while the transverse reinforcement picked up little stress. As bolt stress increased to the point of surface concrete cracking, the stress-slip curve began to level off (Fig. 4.27). At this stage the transverse reinforcement became effective, as indicated by a rapid increase in stress in the ties. For the constant cover of 4.0 in., the amount of stress in the ties was always less than yield at the point of ultimate bolt load.

It is difficult to determine quantitatively the effect of transverse reinforcement on the behavior of bolt groups in this series of tests. Clearly the spiral or tie must be located such that it will be effective in restraining the concrete cover as a wedge-splitting failure is initiated. A spiral 5.2 in. above the bolt and 3.5 in. in front of the washer was effective in restraining the cover and adding ductility to the system. Similar results were not obtained in groups with shallow cover. It can be concluded that the spirals had a minimal effect on the stiffness of the bolt groups, since a significant stress was not observed until considerable cracking had already occurred.

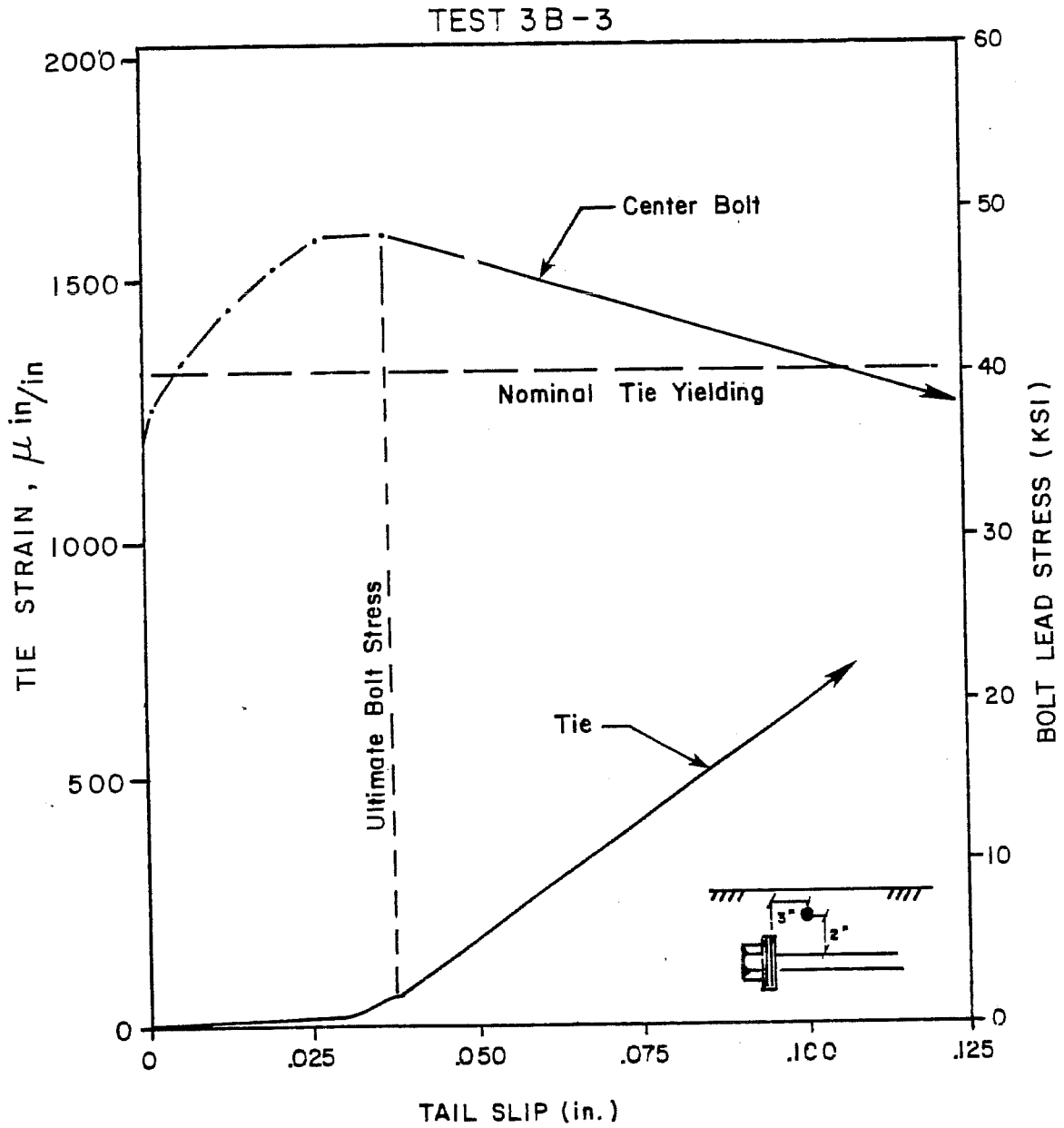

Fig. 4.27 Tie strains, 3B-3

CHAPTER 5

COMPARISON OF BOLT GROUP TESTS

5.1 Introduction

The prime variables studied in these tests were (1) bolt spacing and (2) clear cover. In order to examine the effects of these parameters on bolt behavior, the response of the anchor bolt groups is compared in terms of normalized bolt tension ($T_b/\sqrt{f'_c}$) versus lead slip curves. These curves represent an average value of normalized bolt tension for the bolts in each group (upper two bolts in 4-bolt group). Normalization of the bolt tension with respect to $\sqrt{f'_c}$ has been shown by Hasselwander et al. [1] to satisfactorily account for the effect of variable concrete strength on the strength and stiffness of anchor bolts used in similar applications. The effect of staggering bearing areas and of reducing bearing area are discussed briefly.

In addition, it should be noted that the location of spiral reinforcement was not a controlled variable in this series of tests. As mentioned before, it is hard to define the effect that spiral confinement had on both the strength and slip response of the bolt groups. Other factors, such as the location of the longitudinal reinforcement, could also have affected bolt group behavior. However, the spiral and longitudinal reinforcement seem to play only a minor role in defining the ultimate strength of a bolt group.

As was discussed in Chapter 3, 2-bolt groups were tested rather than 4-bolt groups because the upper level bolts always controlled behavior. Figure 5.1 shows a comparison of two tests with the same geometry. Note that the response is virtually identical.

5.2 Effect of Bolt Spacing

Figures 5.2 - 5.4 illustrate the effect of bolt spacing on the load slip response of different bolt groups. In each figure the clear cover is constant. The slopes of the curves are essentially the same until the bolt groups approach ultimate. For a given clear cover, an increase in ultimate bolt capacity can be expected with increased bolt spacing.

5.3 Effect of Clear Cover

Figures 5.5 - 5.8 show the effect of clear cover on bolt group behavior for different tests. In each figure, the bolt spacing was constant while the clear cover ranged from 2.4 in. to 7.4 in. Although the initial stiffness for each test is about the same, both the strength

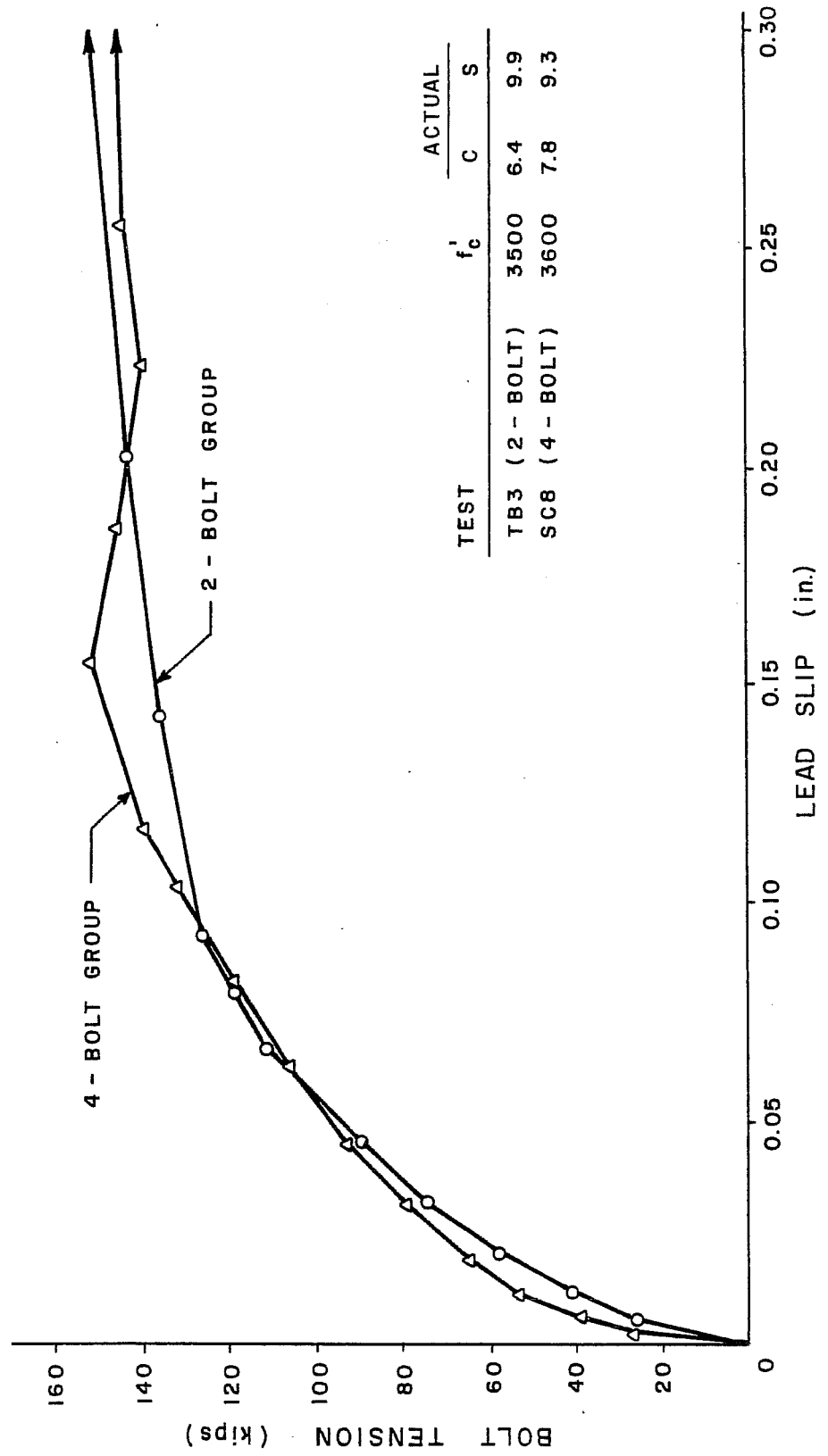

Fig. 5.1 Bolt tension vs. lead slip for 2-bolt and upper bolts in 4-bolt groups

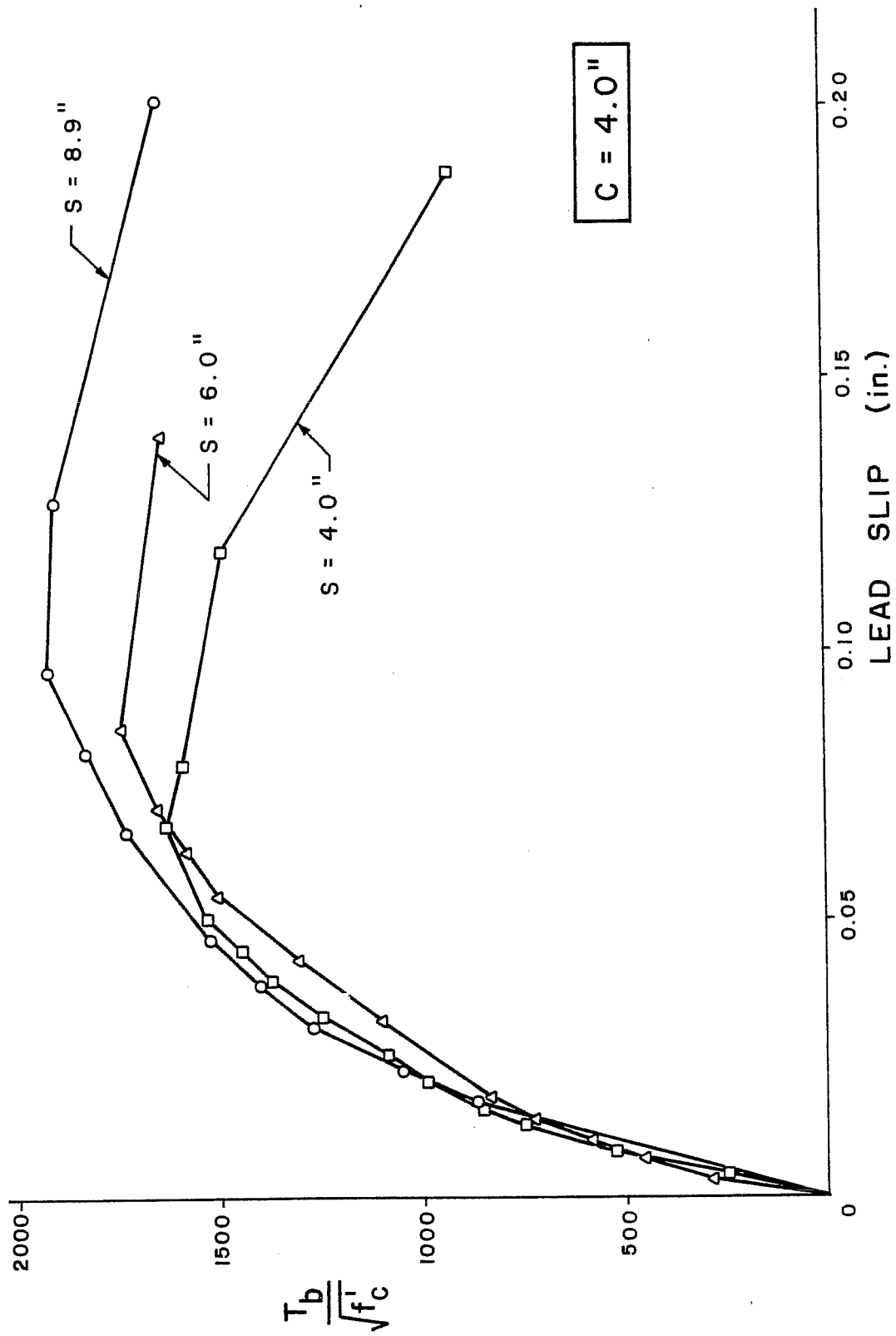

Fig. 5.2 Effect of bolt spacing: TB1, TB5, TB8

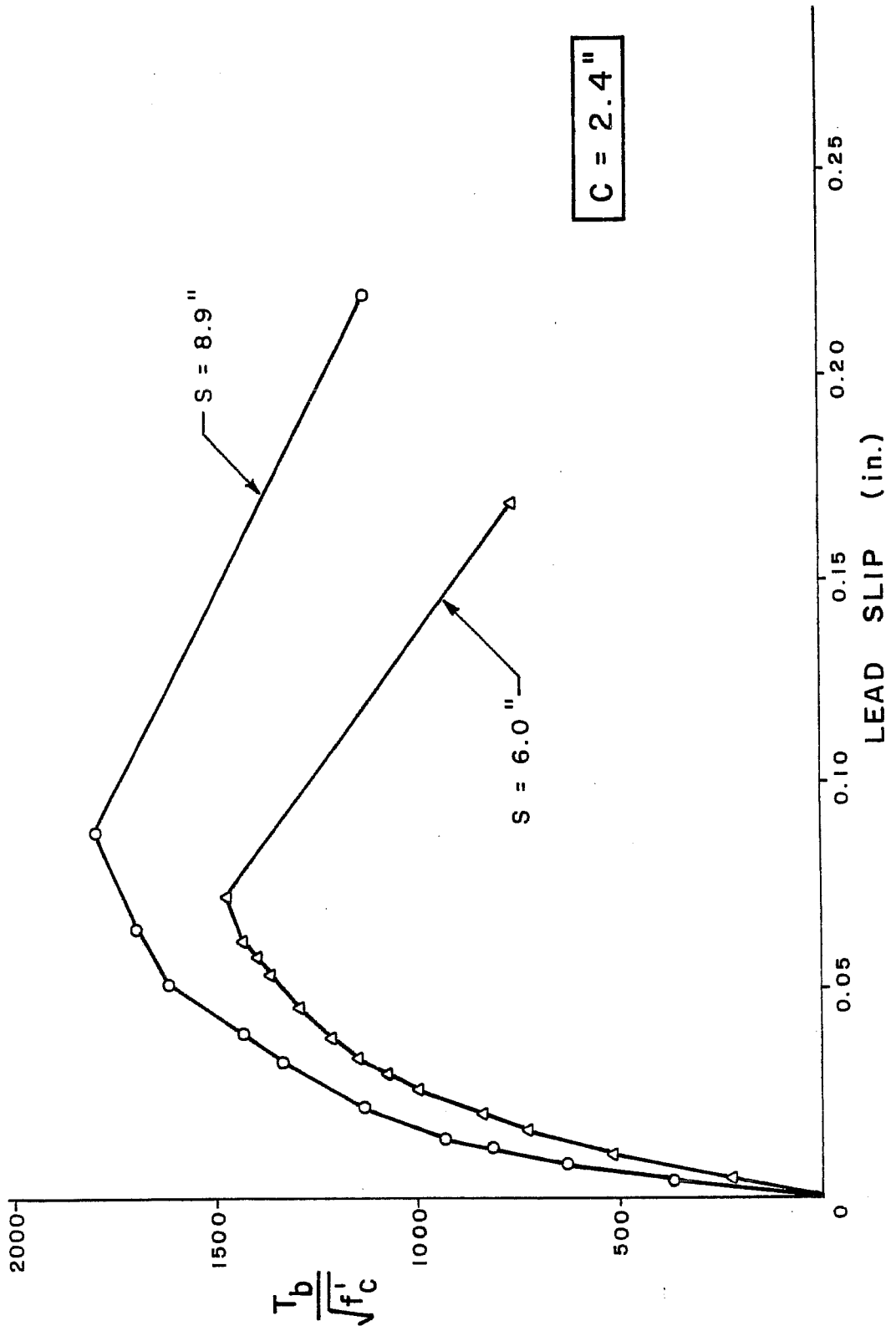

Fig. 5.3 Effect of bolt spacing: TB4, TB7

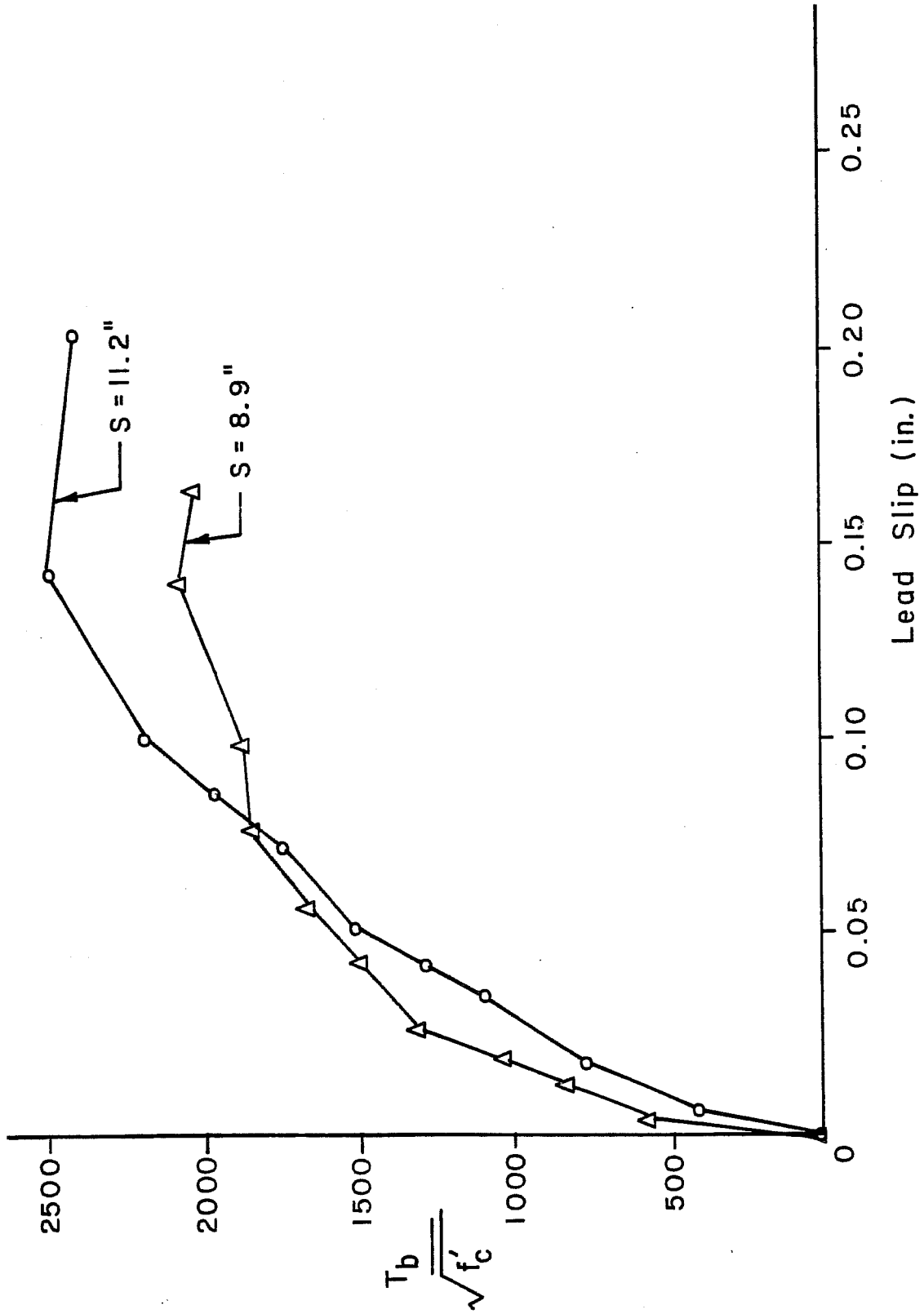

Fig. 5.4 Effect of bolt spacing: SC2, SC4

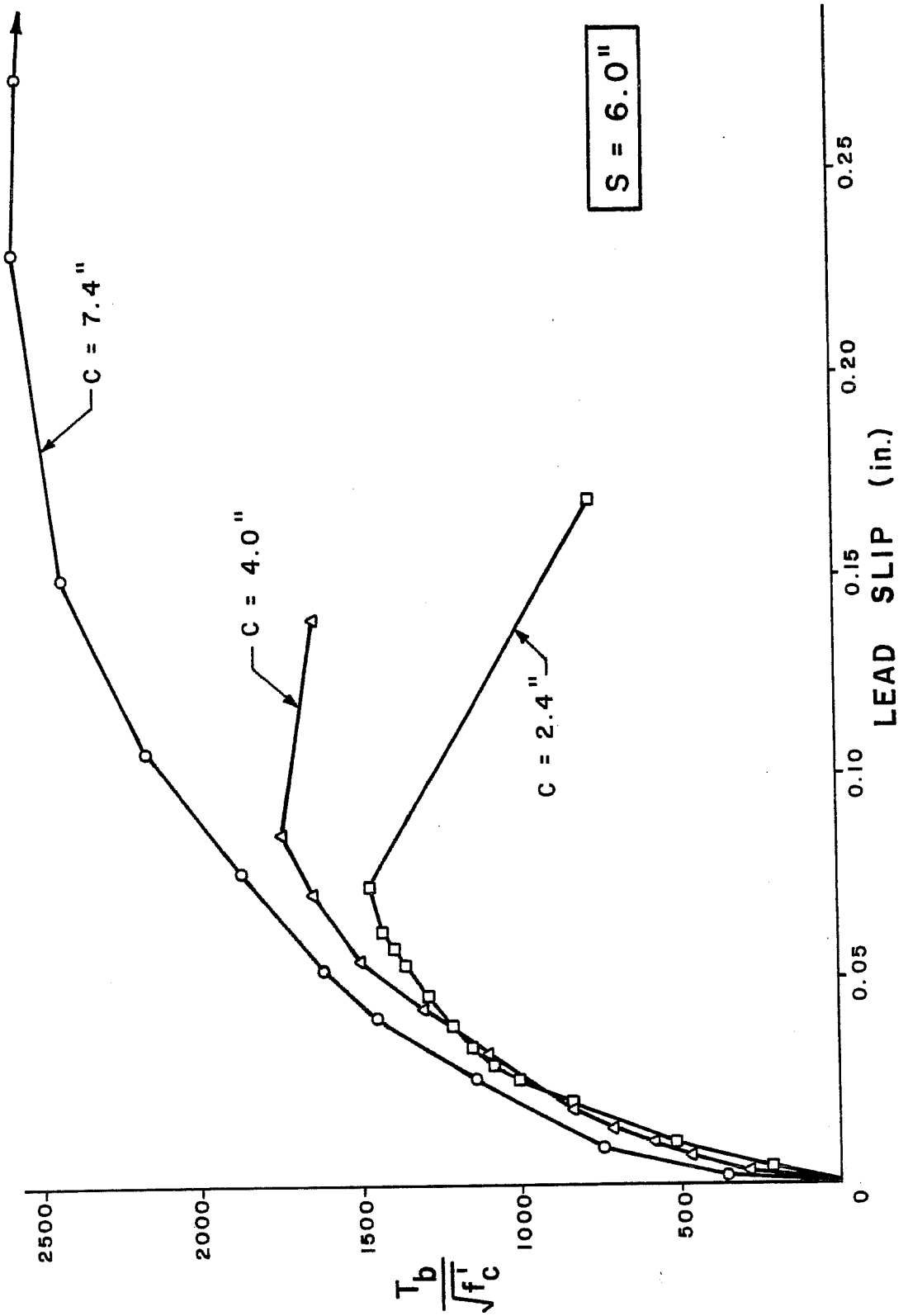

Fig. 5.5 Effect of clear cover: TB5, TB7, TB9

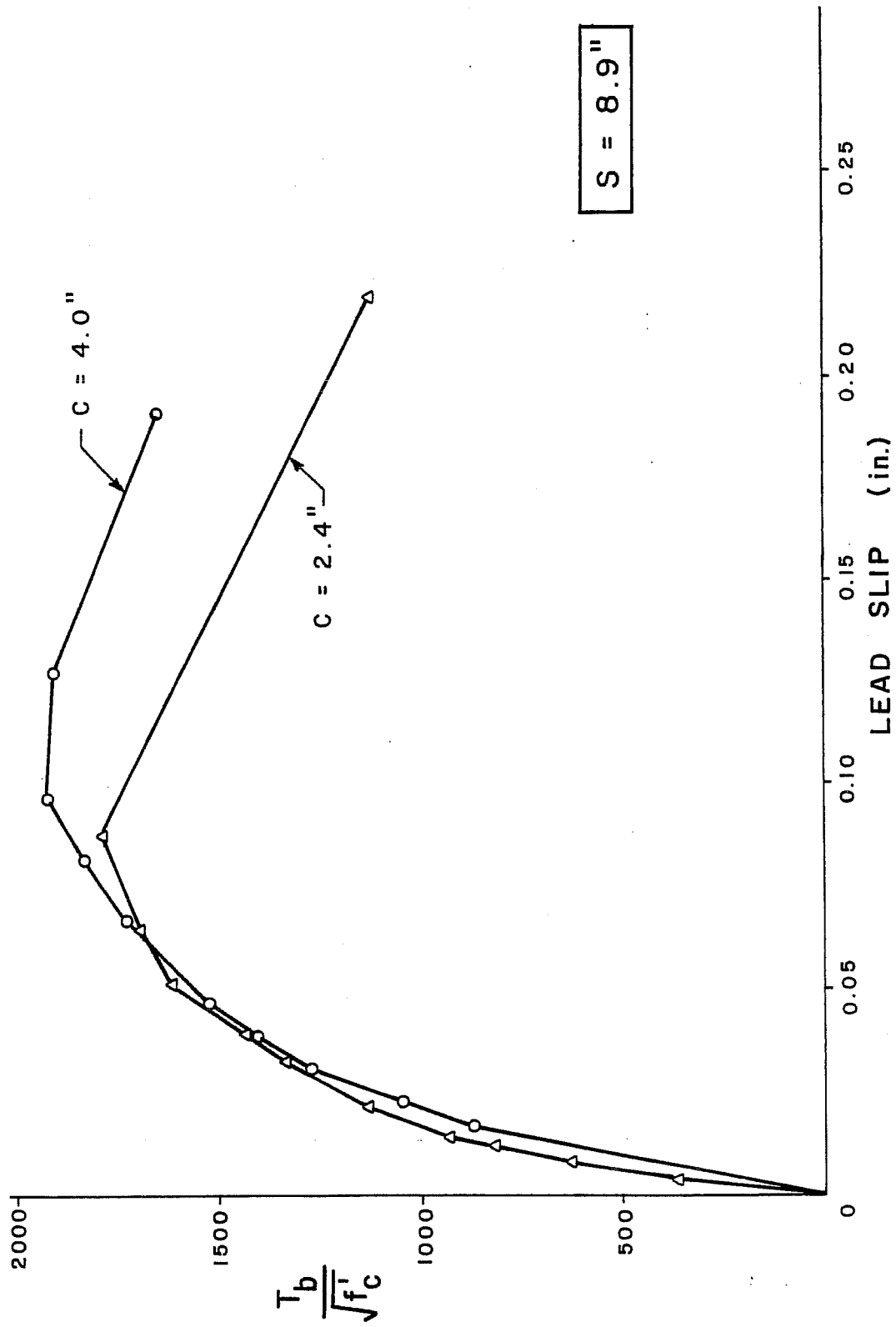

Fig. 5.6 Effect of clear cover: TB1, TB4

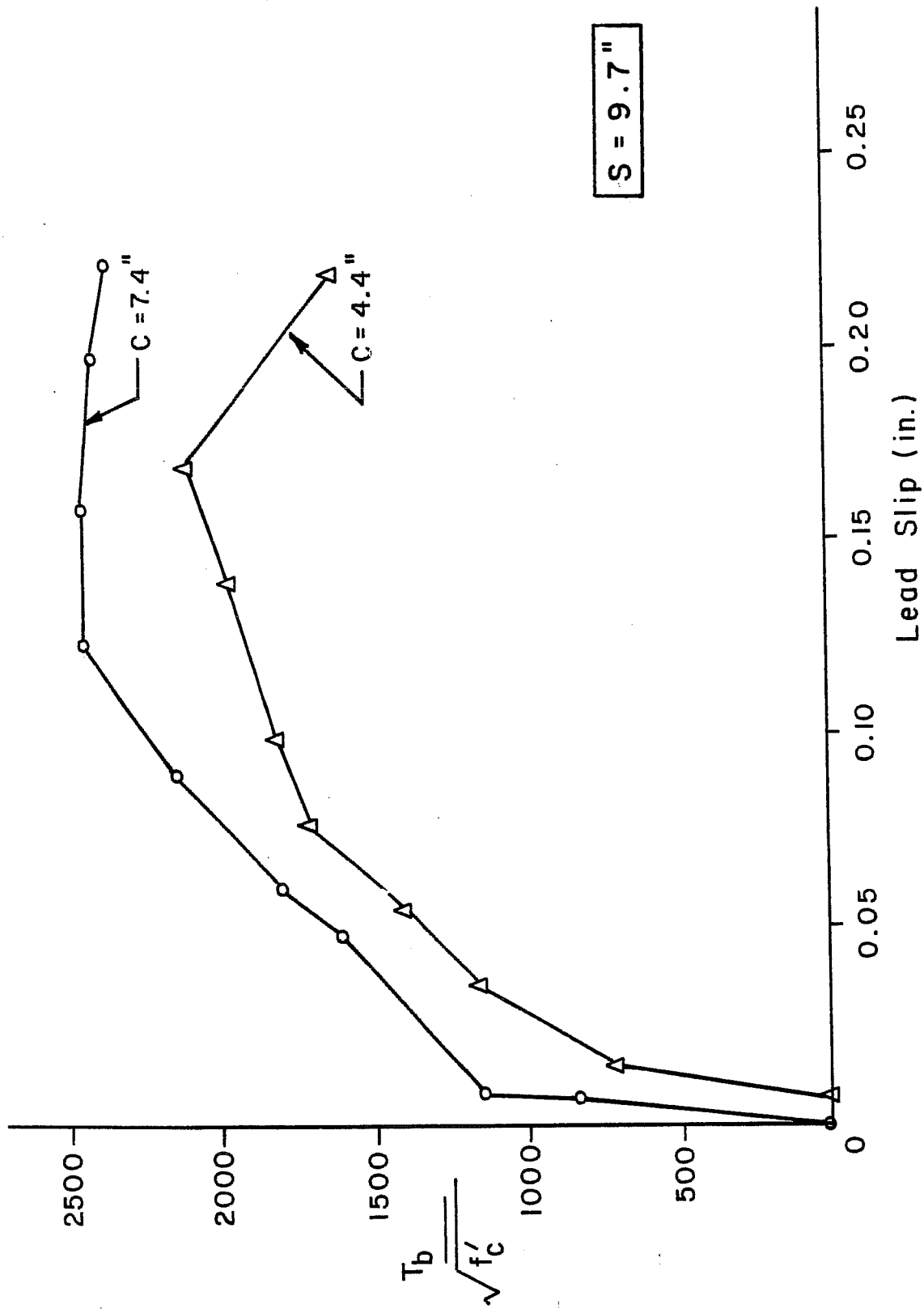

Fig. 5.7 Effect of clear cover: SC6, SC8

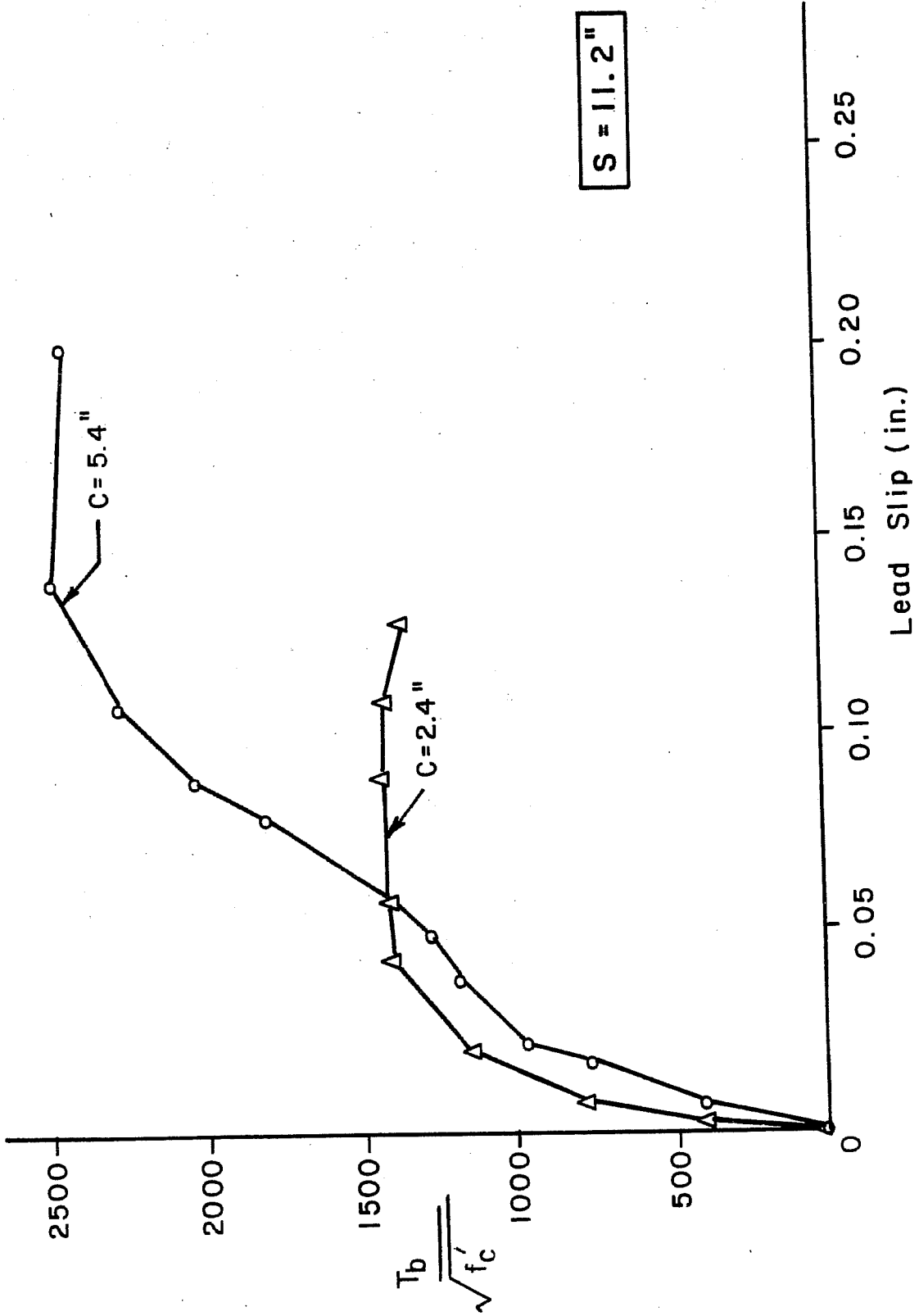

Fig. 5.8 Effect of clear cover: SCI, SC4

and the ultimate slip response of the bolt groups are significantly affected by a change in clear cover. Groups with 2.4 in. and 4.0 in. covers lost capacity rapidly once ultimate was reached, while groups with larger cover exhibited large slip without loss of bolt force.

In general, a definite trend of increasing ultimate capacity with increased clear cover is indicated in these tests. Also, tests with large cover generally sustained ultimate load capacity while undergoing a large amount of slip, while tests with shallow cover seem to fail abruptly with little warning. It should be noted, however, that the large slip capacity is associated with spiral yielding; therefore, an abrupt failure would also be expected for large cover if no transverse reinforcement were provided.

The spacing and location of transverse reinforcement is important in confining the concrete cover and in the ductility of the system. With regard to the stiffness of the bolt group, however, transverse reinforcement had minimal influence, since a significant amount of cracking had occurred before the stress in the ties had reached appreciable levels.

5.4 Center Bolt Performance in Three-Bolt Groups

The average bolt stress versus average lead slip curves for the four three-bolt tests are presented in Fig. 5.9. As in the two-bolt groups, an increase in bolt spacing resulted in an increase in group capacity. It is important to note that as spacing increased beyond 6 in. the group ultimate capacity increased only slightly.

The stress-slip curves for the center bolts in each of the three-bolt groups are shown in Fig. 5.10. Included in this graph is the stress-slip curve for test 3B-5, the single bolt reference, to illustrate the relative strength reductions of each center bolt. The increase in spacing allows more complete formation of the individual wedge-splitting mechanisms, resulting in a higher stress in the bolts. As spacing is increased, the center bolt stress approaches that of an individual isolated bolt.

5.5 Effect of Bolt Staggering

Two tests (STG1 and STG2) were conducted on anchor bolts embedded with variable lengths in a group (see Fig. 3.3). The staggered bolt groups are compared in Figs. 5.11 and 5.12 with bolt groups (SC1 and SC2) having uniform embedment length and identical clear cover and spacing.

Three-Bolt Test Series Bolt Stress vs Lead Slip Group Averages

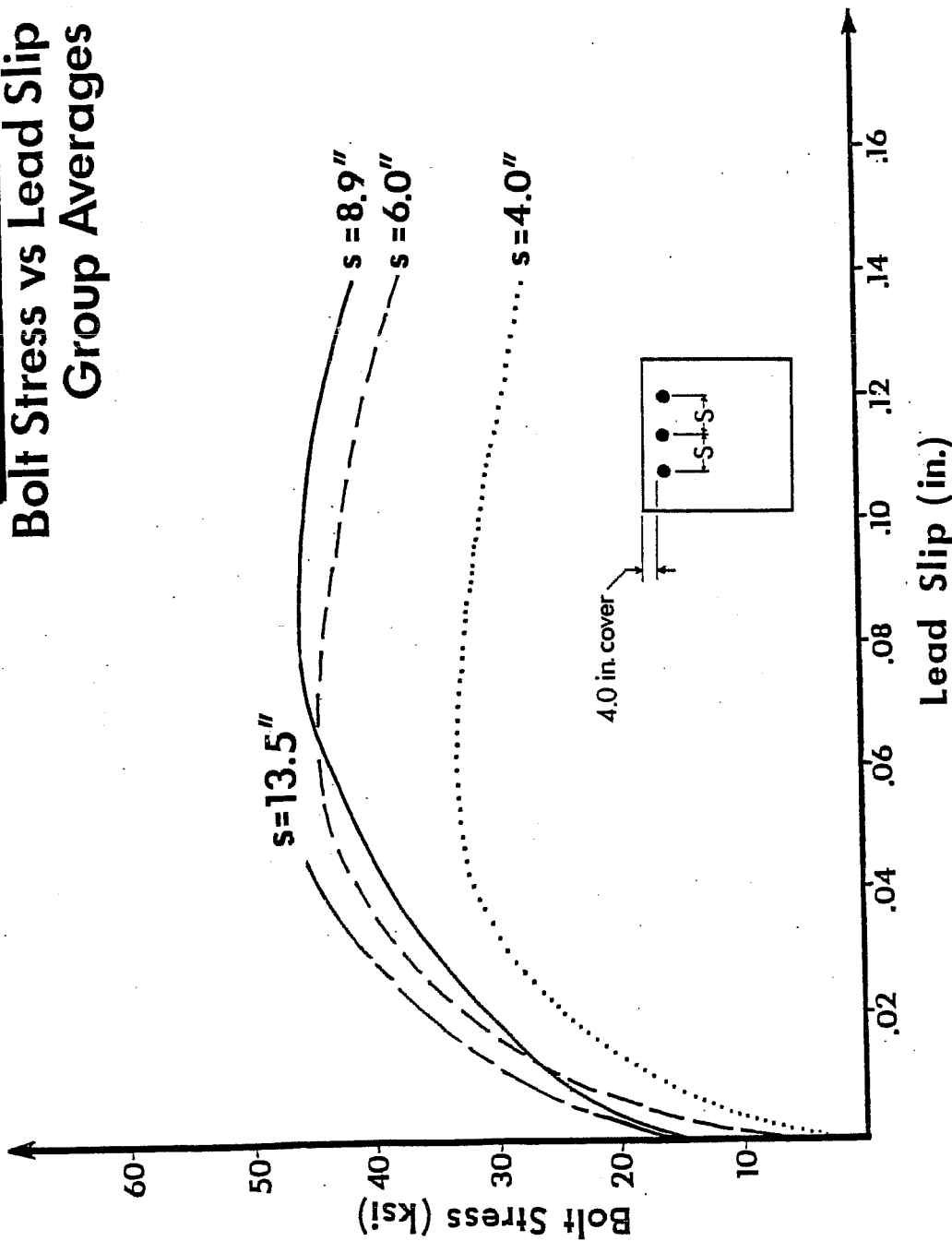

Fig. 5.9 Average stress-slip curves for 3-bolt groups

Three-Bolt Test Series Bolt Stress vs Lead Slip for Center Bolt

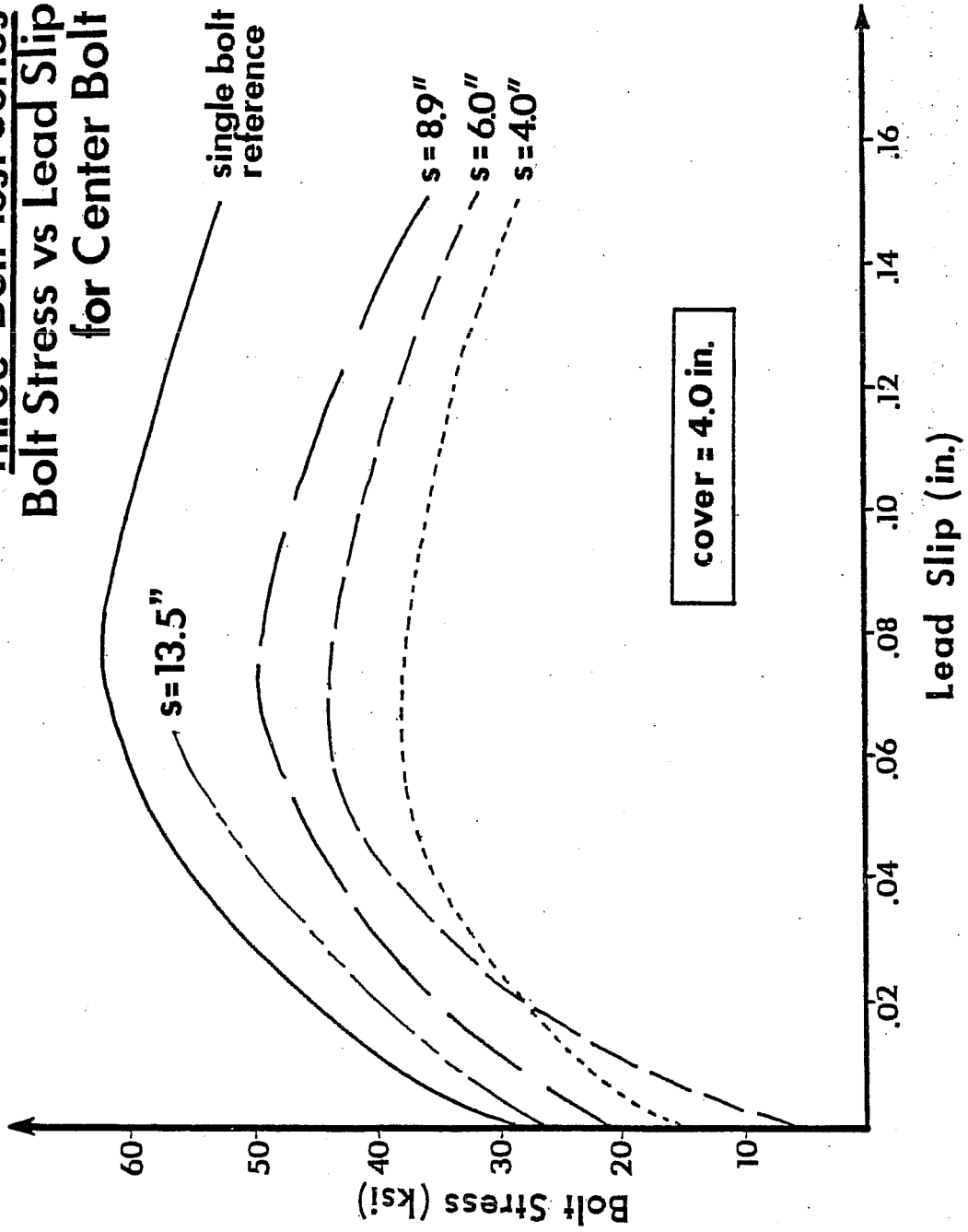

Fig. 5.10 Stress-slip curve for center bolts of 3-bolt groups

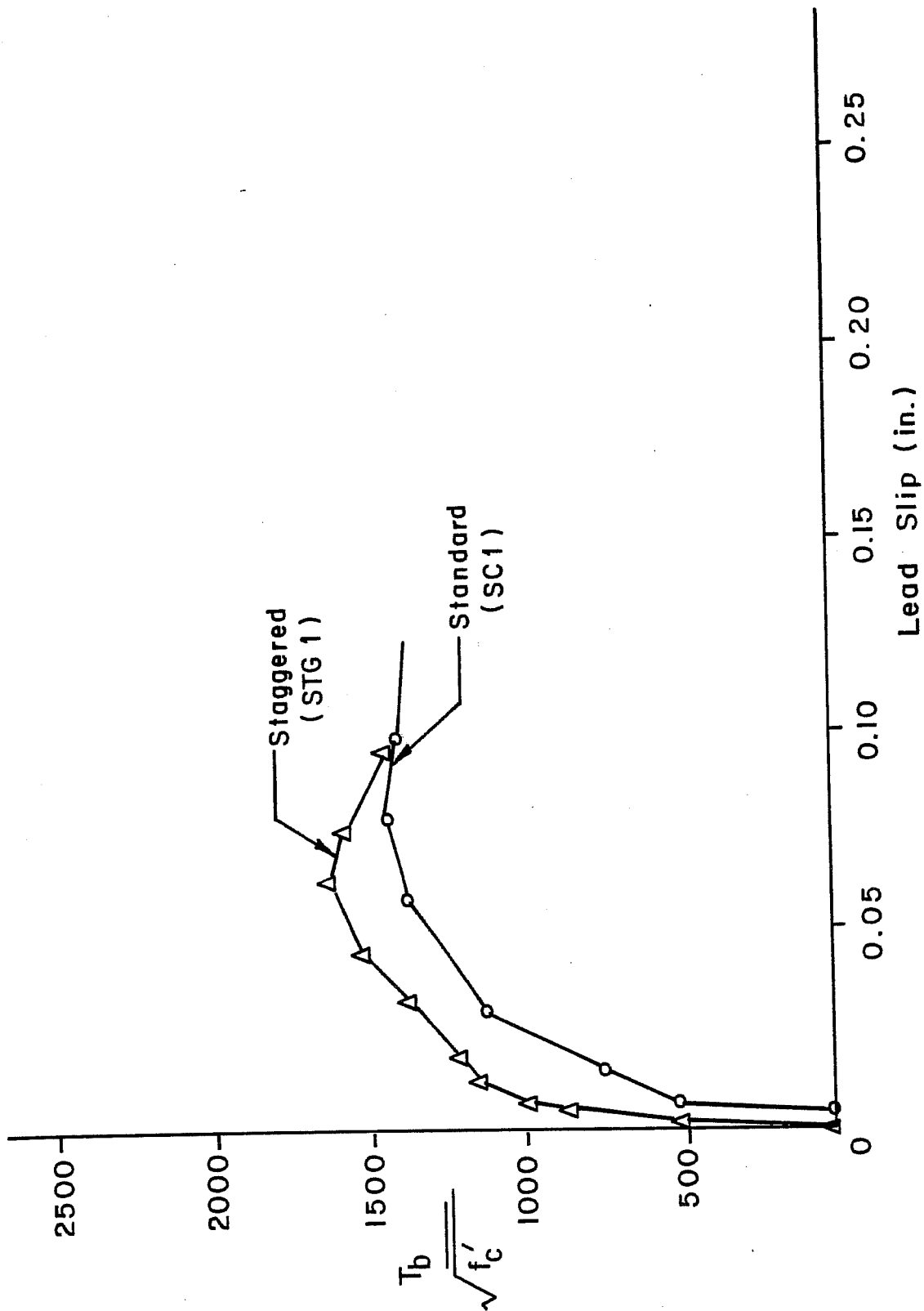

Fig. 5.11 Effect of bolt staggering: SC1, STG1

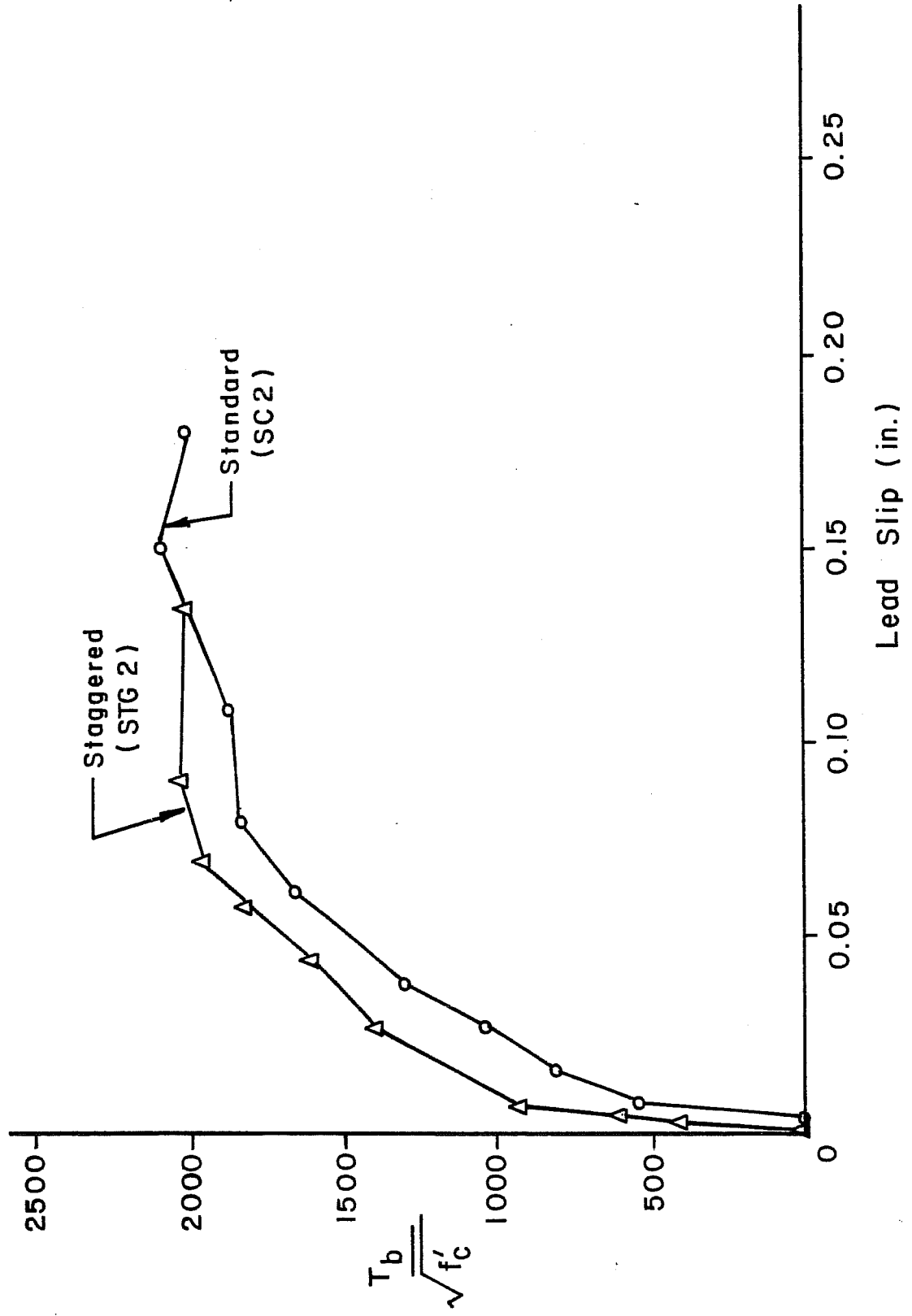

Fig. 5.12 Effect of bolt staggering: SC2, STG2

Staggered bolts in test STG1 with a 2.4 in. clear cover and 11.2 in. spacing showed a slight increase (about 15%) in the average bolt capacity over a bolt group (SC1) with similar geometry and uniform embedded length. In test STG2 with 5.4 in. clear cover and 8.9 in. spacing, staggering did not increase the average bolt capacity. The staggered bolts failed at comparable load levels with considerable interaction of cracking.

Perhaps a distinction can be made between the staggered group embedded in shallow cover and large spacing versus the group with deep cover and small spacing. The fact that cracking near the anchorage zone (prior to failure) is less extensive with shallow, rather than deep cover, explains why staggering was relatively more successful in reducing the bolt interaction for the shallow cover condition. The test results indicate the staggering is not a practical method to increase significantly the tensile capacity of an anchor bolt group. Perhaps an offset of the anchor bolts considerably larger than used in the test program might prove successful in increasing the group capacity. The value of such an alternative in terms of additional bolt material and installation difficulty seems doubtful.

5.6 Effect of Reduced Bearing Area

A nut without washers was placed at the embedded end of anchor bolts in test NOW. In Fig. 5.13, this bolt group is compared with another group (SC6) with washers. In both groups the clear cover and bolt spacing were the same. The average bolt capacity was reduced by 26% when washers were not used at the anchorage end. The anchor bolts in test NOW failed with very little, if any, interaction between adjacent bolts and performed quite well in comparison with isolated bolts having equal bearing area.

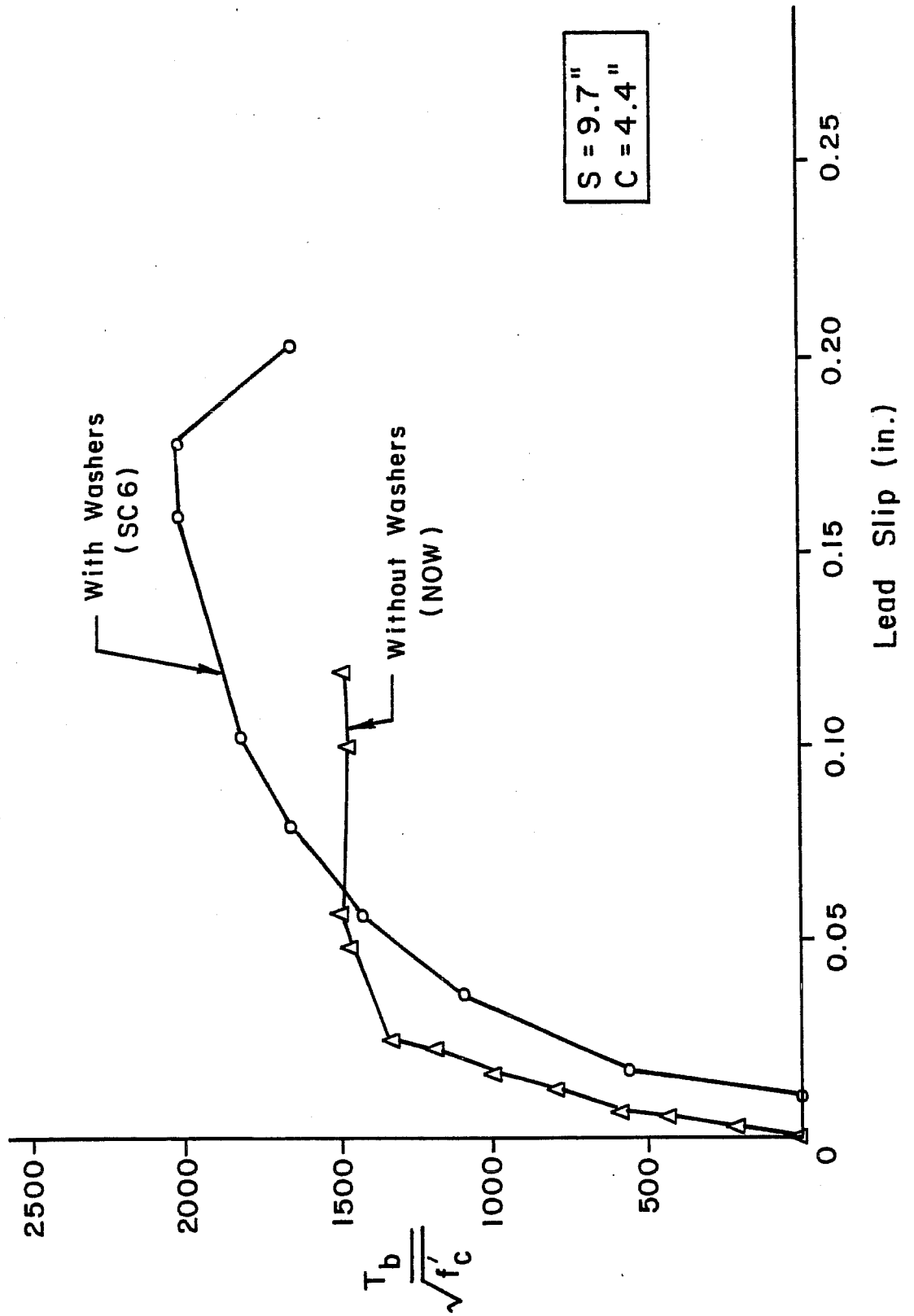

Fig. 5.13 Effect of reduced bearing area: SC6, NOW

CHAPTER 6

DESIGN EQUATION FOR ANCHOR BOLT GROUPS

6.1 Introduction

In this chapter, measured bolt tensile capacities are compared with the predicted capacity of an isolated bolt with similar geometry. A design equation is presented which combines the results of all bolt group tests, including those reported by Hasselwander et al. [1].

6.2 Single Bolt Capacity

The following equation was developed by Hasselwander [1] for predicting the nominal tensile capacity of an isolated anchor bolt failing in a wedge-splitting mode:

$$T_i = 0.14 A_b \sqrt{f'_c} [0.7 + \ln(2C/(D_w - D))] \quad (\text{Eq. 1})$$

where A_b is the net bearing area, D and D_w are the bolt and washer diameter, C is the clear cover, and f'_c is the concrete compressive strength. The embedment lengths (35 in.) were greater than $12(D_w - D)$ as suggested by Hasselwander to ensure a wedge-splitting type failure. Hasselwander's tests were performed on rectangular specimens; however, Lee and Breen [5] reported that the effect of circular specimen shape on bolt capacity was negligible compared to rectangular shape. Therefore, the results of bolts in circular piers will be compared with those in square piers. In obtaining a design equation, it is desirable to isolate the effect of bolt spacing on group strength; therefore, the effect of clear cover can be eliminated by examining the ratio of observed capacity to predicted capacity (T_{\max}/T_i) versus bolt spacing.

In Table 6.1, the main variables and the strength reduction are summarized for the bolt groups. The predicted isolated bolt capacity (T_i) has been calculated based on actual values of clear cover as measured in the anchorage region after testing. Average values of bolt capacity have been used. Test TB2 and SC3 are omitted from the data because of damage prior to testing.

The simplest means of evaluating group strength reduction would be to modify Hasselwander's single bolt equation with a reduction factor to account for the effect of bolt spacing. In Fig. 6.1, values of relative bolt capacity (T_{\max}/T_i) are plotted versus bolt spacing. A straight line fit using a least squares analysis has been used to represent the

Table 6.1 Strength reduction of bolts in a group

Test	f'_c (ksi)	Average T_{max} (kips)	Actual Clear Cover (in.)	Actual C-C Spacing (in.)	T_i (kips)	T_{max} T_i	T_{max} T_n (Eq.6)
<u>4-Bolt Groups</u>							
SC1	3.5	92	2.7	11.4	133	0.69	1.10
SC2	3.6	125	5.7	9.1	198	0.63	1.08
SC4	4.2	162	5.6	11.0	212	0.76	1.23
SC6	3.9	127	4.5	10.0	185	0.69	1.14
SC7	3.6	96	2.4	13.6	124	0.78	1.15
SC8	3.6	152	7.8	9.3	225	0.68	1.15
STG1	3.8	106	2.4	11.2	134	0.79	1.27
STG2	3.9	127	5.4	8.9	198	0.64	1.11
NOW	3.9	95	4.7	10.0	103	0.92	1.54
<u>2-Bolt Groups</u>							
TB1	3.4	117	4.2	9.2	167	0.70	1.20
TB3	3.5	154	6.4	9.9	205	0.75	1.26
TB4	4.6	121	2.8	9.0	155	0.78	1.34
TB5	4.7	119	4.0	6.0	191	0.62	1.20
TB6	4.7	178	4.9	13.5	212	0.84	1.25
TB7	4.2	95	2.7	6.2	144	0.66	1.26
TB8	4.2	106	3.7	4.0	174	0.61	1.27
TB9	4.3	170	7.3	6.0	238	0.71	1.37
<u>3-Bolt Groups</u>							
3B-1	3.6	78 (87)*	4.0	4.0	168	0.46 (0.52)*	0.97
3B-2	3.6	102 (104)	4.0	6.0	168	0.61 (0.62)	1.17
3B-3	3.7	102 (116)	4.0	8.9	168	0.61 (0.69)	1.05
3B-4	3.7	107 (132)	4.0	13.5	168	0.63 (0.79)	0.95
<u>Hasselwander's Tests: 2-Bolt Groups (1 in. dia.)</u>							
H5	2.7	32.4	2.5	5.0	57	0.57	1.13
H10	3.9	49.5	2.5	10.0	69	0.72	1.20
						Avg	1.19
						σ	0.13

* Center bolt values

general trend of the data. The equation of the line is of the following form:

$$T_{\max}/T_i = 0.02S + 0.52 \quad (\text{Eq. 2})$$

The lower bound on the data (largely due to the low values of the three-bolt groups is

$$T_{\max}/T_i = 0.02S + 0.4 \quad (\text{Eq. 3})$$

Therefore, modifying Eq. 1, the nominal tensile capacity of an anchor bolt in a two-bolt group, failing in a wedge-splitting mode, can be represented by

$$T_n = 140 A_b \sqrt{f'_c} [0.7 + \ln(2C/(D_w - D))](0.020S + 0.4) \quad (\text{Eq. 4})$$

where T_n is the nominal tensile capacity (lbs), A_b is the net bearing area (in.²), D and D_w are the bolt and washer diameter (in.), C is the clear cover to the bolt (in.), S is the center-to-center bolt spacing (in.), and f'_c is the concrete compressive strength (psi), with $(0.020S + 0.4) \leq 1.0$.

Theoretically, the strength of a two-bolt group should vary between 50% and 100% of the nominal capacity. Using the above equation, bolt groups would reach full capacity at a spacing of 30 in. It is important to note that in the range of bolt spacings presented here, capacities fell between 57% and 84%. Clearly, more test data are needed to accurately define the trend at large spacings; however, the range presented (4.0 in. to 13.6 in.) represents the majority of practical applications for highway related structures.

6.3 Design Equation

For design, two additional factors must be accounted for: (1) a capacity reduction factor (ϕ) must be included to account for scatter in test data and for variation in material properties and construction tolerances, and (2) failure of anchor bolt installations should be governed by bolt yielding to ensure ductility in the event of overload. Therefore, an acceptable design procedure could be based on the following:

For anchor bolt groups embedded in reinforced concrete piers and loaded in pure tension, design of pier shall be based on:

$$T_u \leq \phi T_n \quad (\text{Eq. 5})$$

where T_u is the factored bolt tensile capacity, ϕ is a capacity reduction factor of 0.75, and T_n is the nominal tensile capacity of the anchor bolt (lbs), computed by:

$$T_n \leq A_{sm} f_y < 140' A_b \sqrt{f'_c} [0.7 + \ln(2C/(D_w - D))] K_s \quad (\text{Eq. 6})$$

where

- A_b = net bearing area, in.², but not greater than $4D^2$
 A_{sm} = mean tensile area of anchor bolt, in.²
 D = bolt diameter, in.
 D_w = washer diameter, in., with thickness not less than $D_w/8$
 C = clear cover to bolt, in.
 K_s = spacing reduction factor = $(0.02S + 0.40) \leq 1.0$
 S = center-to-center bolt spacing, in.
 f'_c = concrete compressive strength, psi
 f_y = yield strength of the bolt material, psi

The embedment length (distance from critical section to bearing surface) must be not less than $12(D_w - D)$

It is important to note that the right side of Eq. 6 applies to bolts loaded in pure tension which fail by wedge-splitting. By requiring $A_{sm} f_y$ to be less than the capacity at failure in the concrete, the design bolt strength will be governed by the tensile capacity of the bolt material. The limits on bearing area, embedment length, and washer thickness were imposed by Hasselwander [1] to ensure that any failure in the concrete is of the wedge-splitting type. In addition, it is important to note that only bolts with a diameter of 1-3/4 in. were tested. Hasselwander's tests with 1 in. diameter bolts were consistent with results of the 1-3/4 in. tests. Therefore, Eq. 6 is likely to give a reasonable estimate of group strength for the range of bolt diameters typically used in highway structures. Care should be taken, however, in applying Eq. 6 to installations with bolt diameters greater than those tested, since the embedment length required to ensure a wedge-splitting failure for such diameters might vary considerably from bolts tested.

Table 6.1 lists the ratio of the measured bolt ultimate strength to that predicted from Eq. 6. The average ratio for all the tests is 1.19, with a standard deviation of 0.13.

The effect of continuous templates for several bolts and plate thickness on anchor strength will be discussed in the next chapter and adjustments to Eq. 6 will be described.

CHAPTER 7

SINGLE BOLT TEST PROGRAM

7.1 Introduction

Current SDHPT specifications for anchor bolts in traffic signal and overhead sign supports were reviewed and seven tests were devised to investigate the performance of single anchor bolts or bolts with a common bearing plate. Specifically, the ultimate tensile capacity of the bolts, effect of bolt material, and effect of anchorage type were investigated. In addition, a post-tension test was conducted to determine the bolt stress/nut rotation relationship. The purpose of the tests was to verify design procedures with test results.

Highway department specifications were paralleled as closely as possible in all tests. State Department of Highways and Public Transportation drawings were obtained for guidance in the construction of the anchor bolt installations being tested. Figure 7.1 illustrates the detail for the traffic signal support while Fig. 7.2 shows the detail for the overhead sign support. Notice that bolts have 90° bends are only used in the traffic signal supports while the overhead sign supports utilize a nut and circular steel plate anchorage. Single anchor bolts having three different anchorages and two steel grades were tested. Details of the anchorages are presented in Fig. 7.3. Although a constant embedment length was not used, the influence of embedment length was negligible with regard to load-deflection response. Two specimens were cast with four tests conducted on the first specimen and three tests on the second.

Test Objectives. The single anchor bolt test program had three primary objects, as listed below:

- (1) Behavior of anchorage--hook performance, strap effect
- (2) Anchorage strength--90° bend, 90° bend plus strap, nut plus strap
- (3) Post-tensioning behavior--bolt stress/rotation relationship, creep effects.

In this chapter a description of the test program, the test results, and analysis of data are presented. Whenever possible, repetition of previously described test procedures has been eliminated for brevity.

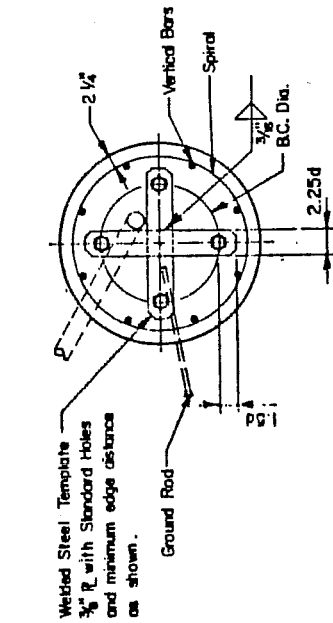

ANCHOR BOLT SIZE	
DIA.	LENGTH* THREAD*
3/4"	1-6" 3"
1 1/4"	2-11" 5"
1 1/2"	3-4" 6"
1 3/4"	3-10" 7"
2"	4-3" 8"

* Minimum dimensions are given.

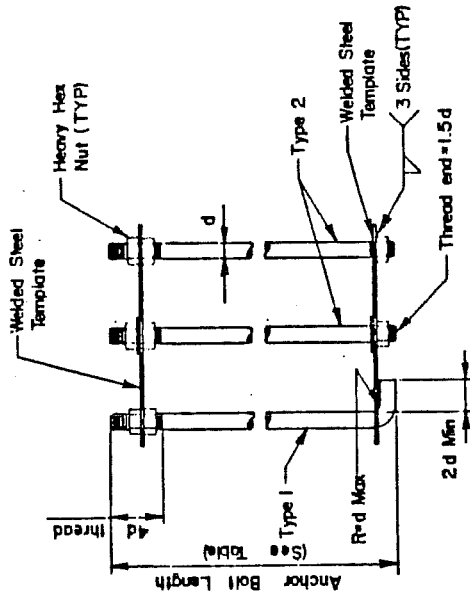

HOOKE ANCHOR
(TYPE 1)

NUT ANCHOR
(TYPE 2)

ANCHOR BOLT ASSEMBLY

FOUNDATION DESIGN TABLE

FDN. SHAFT TYPE	DRILLED SHAFT DIA.	REINFORCING STEEL VERTICAL BARS	DRILLED SHAFT LENGTH-Feet					ANCHOR BOLT DESIGN III		MAX. FIN. DESIGN LOADS MOMENT K-ft	SHEAR K-11	TYPICAL APPLICATION		
			TEXAS CONE PENETROMETER, N blows/ft	10	20	40	80	ANCHOR BOLT DIA.	ANCHOR TYPE					
24-A	24"	4-#5 "2 or 12"	5	4	3	3	3	3/4"	36	12 3/4"	1	10	1.0	Pedestal pole, pedestal mounted controller.
24-B	24"	6-#5 "2 or 12"	9	8	7	6	6	1 1/4"	36	15"	1	45	1.5	Small luminaire pole assembly.
30-A	30"	8-#6 "3 or 12"	10	9	8	7	6	1 1/4"	55	17 1/2"	1 or 2	60	3.0	Medium luminaire pole assembly.
30-B	30"	6-#7 "3 or 12"	12	11	10	9	7	1 1/4"	55	17"	1 or 2	80	4.0	Large luminaire pole assembly.
30-C	30"	8-#9 "3 or 9"	15	14	12	11	8	1 1/4"	55	17"	1 or 2	80	5.0	Medium mast arm pole assembly.
36-A	36"	12-#9 "3 or 6"	17	16	14	13	10	2-1/4"	55	21"	1 or 2	250	8.0	Large mast arm pole assembly. Extra large mast arm pole assemblies. Street pole taller than 30' 0" street pole with mast arm.

Fig. 7.1 SDHPT specifications for traffic signal foundations

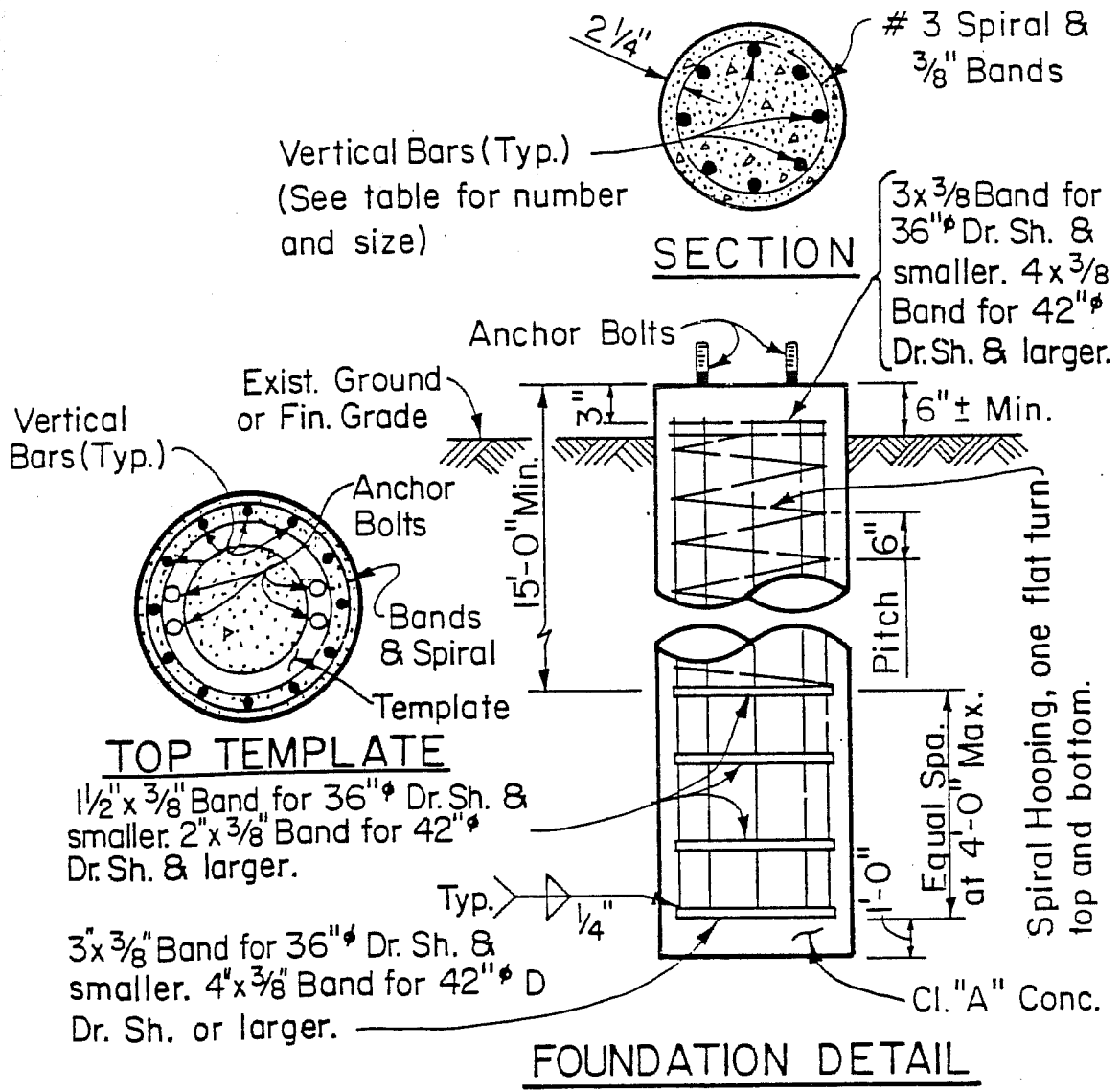

Fig. 7.2 SDHPT specifications for overhead sign support foundations

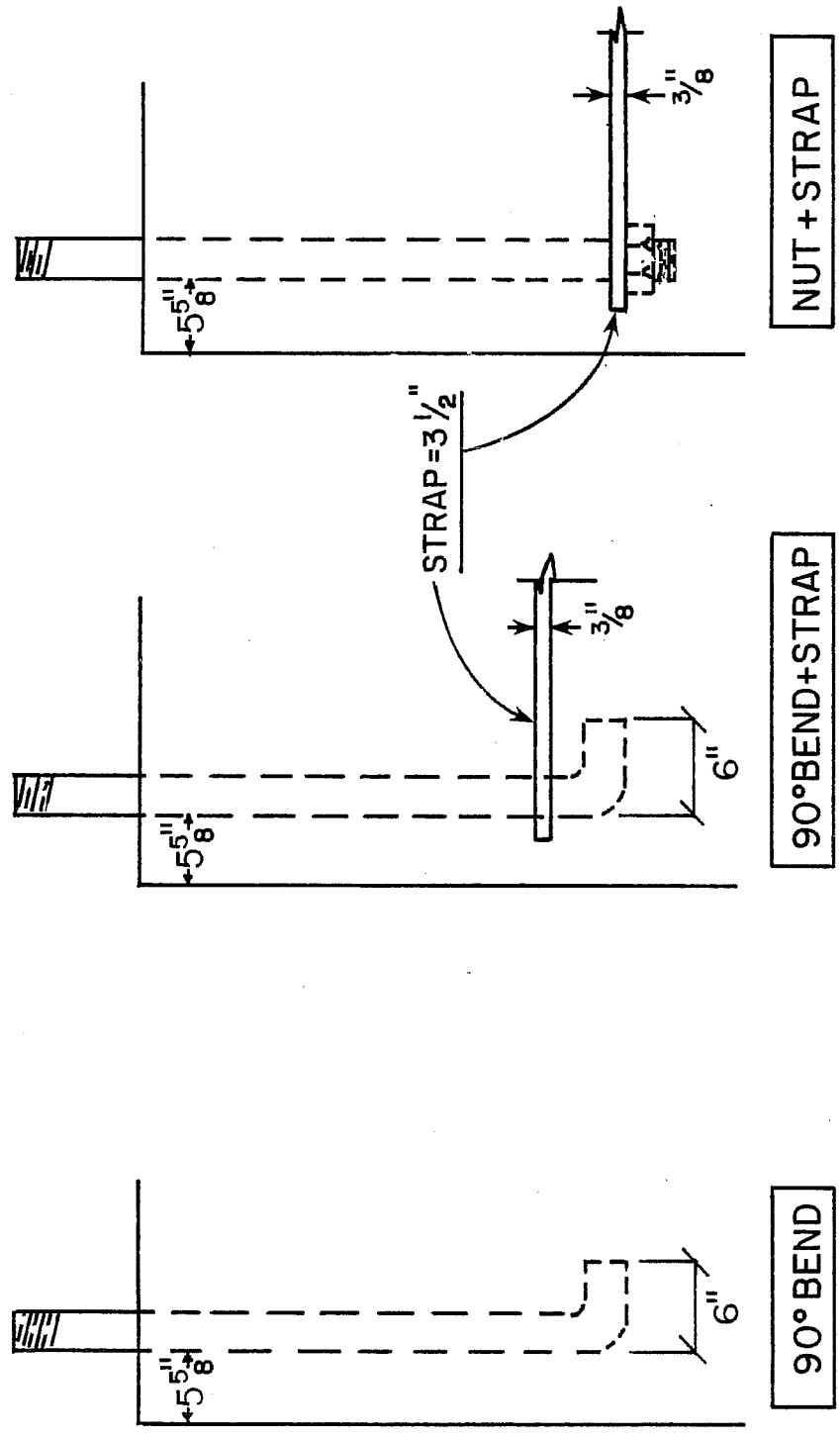

Fig. 7.3 Anchorage details

7.2 Experimental Program

The same basic experimental apparatus and procedure used for the bolt group tests was used for the single bolt tests. A summary of the single bolt tests appears in Table 7.1.

Two specimens were cast for the tests in this phase. A sketch of the first specimen cross section is shown in Fig. 7.4a. The 30 in. diameter specimen size was chosen as typical for highway applications. All four bolts in this specimen had 90° bends--two included a steel strap. The strap was fabricated from ASTM A36 steel and was dimensioned according to SDHPT specifications. Eight #9 reinforcing bars provided support in the longitudinal direction. Transverse reinforcement consisted of a spiral fabricated from #4 plain reinforcing bar and placed at a 9 in. vertical pitch. Clear concrete cover to the spiral was maintained at 2 in. Figure 7.4b shows the bolt arrangement with 90° bends and steel strap plates in place in the cardboard form.

The remaining single bolts were anchored in a 42 in. diameter specimen. A sketch of the second specimen cross section is shown in Fig. 7.5a. The anchorage for the single bolts in this specimen consisted of a nut and steel strap, as shown in Fig. 7.5b. A two-bolt arrangement, as used in overhead sign supports, was also embedded in the specimen. A typical 16 in. diameter drilled shaft was simulated by shifting the circular steel plate toward on edge. The two-bolt group was anchored using standard nuts. Twenty-six #11 reinforcing bars were placed in the longitudinal direction and the #4 spiral was fastened at a 6 in. vertical pitch. Clear cover was maintained at 2 in.

Two different grades of steel were used in the fabrication of the six anchor bolts. The low strength bolts conformed to ASTM A36M55, which provides a minimum yield strength of 55 ksi. The high strength bolts had a minimum yield of 105 ksi (ASTM A193B7). The 90° hooks in the bolts were supplied by the manufacturer.

Both specimens were cast with commercially obtained ready-mix concrete. The same mix design used in previous tests was also specified in these tests to produce 3600 psi compressive strength concrete.

The spiral was fabricated from Grade 40, #4 plain bar. The longitudinal bars inside the spiral were either #9 or #11.

Construction was the same as for the bolt groups in circular shafts. The bolts were positioned and fastened to the rebar cage outside the form. The entire cage/bolt assembly was lifted and placed in the form. This was necessary because the two interior steel plate arrangements made working inside the form impossible. Also, wooden slats, rather than a precut template, were used to support and position the bolts inside the form during concrete placement.

Table 7.1 Summary of single-bolt test series

Test	Bolt Material	Anchorage	Embedment (in.)	f'_c (ksi)
SB-1	A193 B7	90° bend	42	4.0
SB-2	A36 M55	90° bend	35	4.0
SB-3	A193 B7	90° bend + strap	35	4.0
SB-4	A36 M55	90° bend + strap	42	4.0
SB-5	A193 B7	nut + strap	35	3.5
SB-6	A36 M55	nut + strap	35	3.5
TB	A193 B7	nut + circular plate	35	3.5

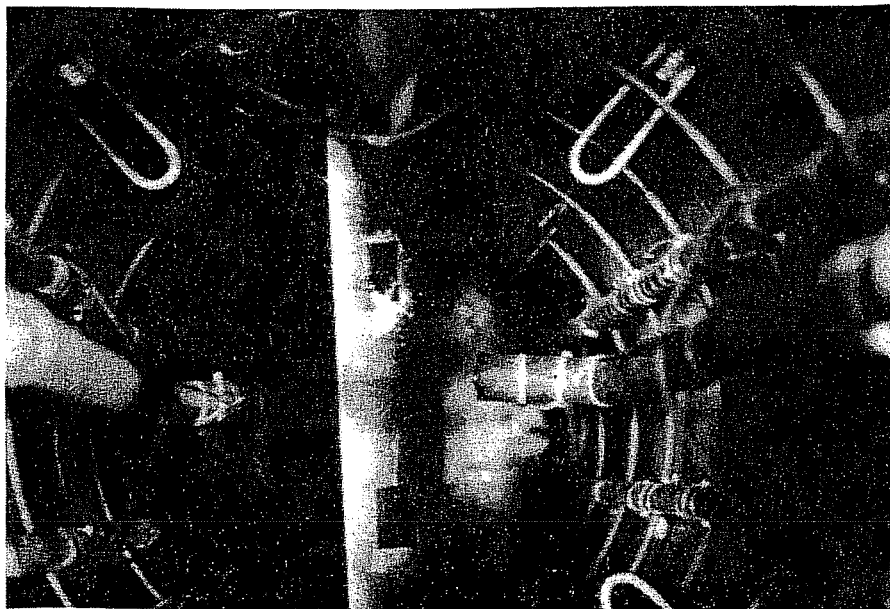
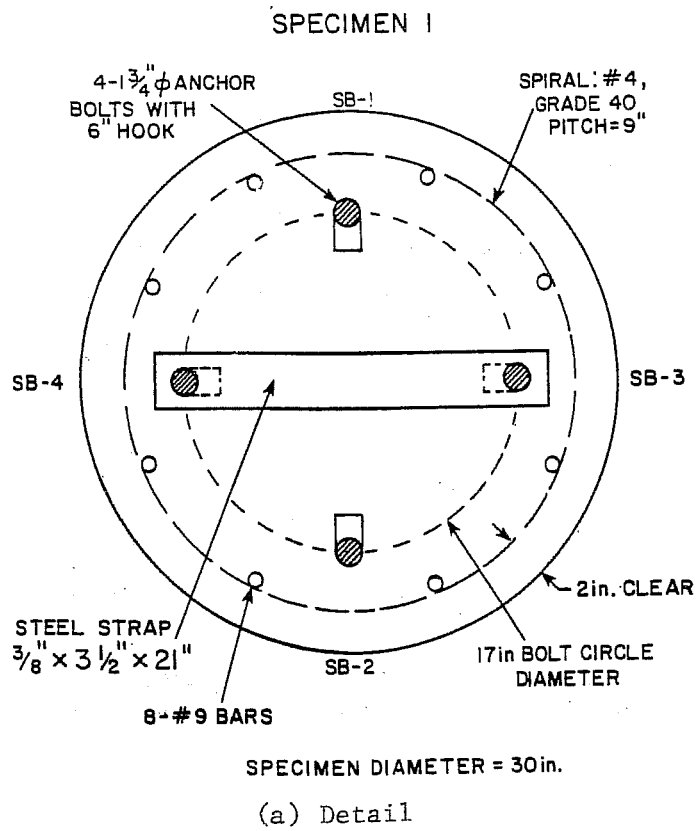

(b) Plan view of specimen 1 prior to casting

Fig. 7.4 Specimen 1

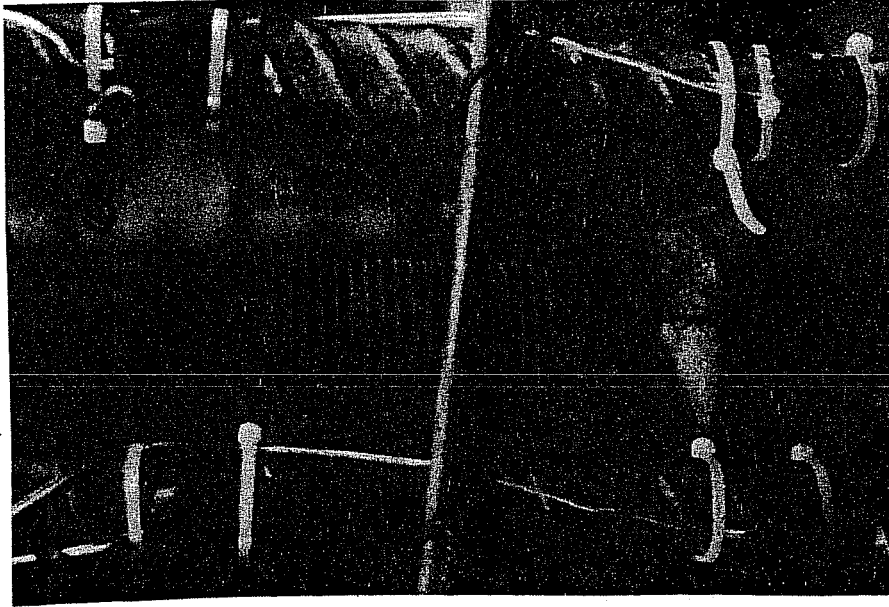

(b) Nut/steel strap anchorage

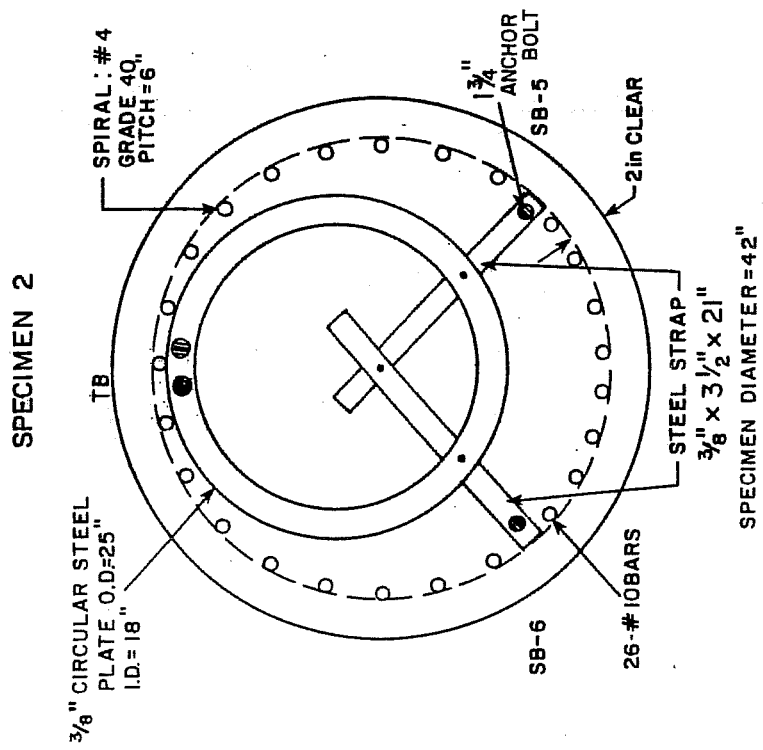

Fig. 7.5 Specimen 2

Electrical resistance strain gages were used to monitor stresses in the bolts and in the longitudinal reinforcing bars. Gage locations on the various bolt/anchorage arrangements are shown in Fig. 7.6.

The same loading system used in the bolt group tests was used for testing the single anchor bolts. The loading beam was designed for two-bolt and four-bolt groups, and for the single bolt tests the base plate was modified.

7.3 Test Results

Although the anchorages used in this series of tests were different than in previous tests, bolt behavior under loading was observed to be essentially the same. Displacement of the bolt increased steadily with application of load until ultimate was reached. At this point, the ultimate load could no longer be sustained and the bolt slip increased rapidly. Ultimate load was reached when the anchorage end failed in bearing, the concrete cover split and began to spall, or the bolt surpassed its yield strength.

7.3.1 Load-Slip Relationships. Bolt stress versus lead slip curves for six single bolt tests are shown in Figs. 7.7, 7.8, and 7.9. Each graph illustrates the load-slip response for the same anchorage but with different bolt materials. Yielding of the 90° bends in tests SB-1 and SB-2 is indicated in Fig. 7.7.

It is interesting to note that in the single bolt tests in which the anchorage included a 90° bend, yielding of the hook determined the failure of the system, except for the high-strength bolt having the hook and steel strap (SB-3).

The initial slope of the load-slip curves for the nut plus strap anchorages (Fig. 7.9) was quite low. This may have been due to the bearing of the nut against the strap. It is unlikely that cement paste filled the gap and some seating was necessary.

7.3.2 Surface Crack Development. In tests SB-1 and SB-2 (90° bends only), no cracking of the concrete surface was observed at any time during the test. Failure of the anchor bolt was the result of yielding of the 90° hook during loading. No cone of crushed and compacted concrete formed at the anchorage; consequently, the absence of wedge-splitting action produced no surface cracking.

Limited surface cracking was observed in tests SB-3 with a 90° bend and strap, as illustrated in Fig. 7.10. Note that the pattern is not the same as that in tests where washers provided anchorage. Although test SB-4 had an anchorage similar to SB-3, failure of the system was by yielding of the bolt; therefore, no cracking was observed.

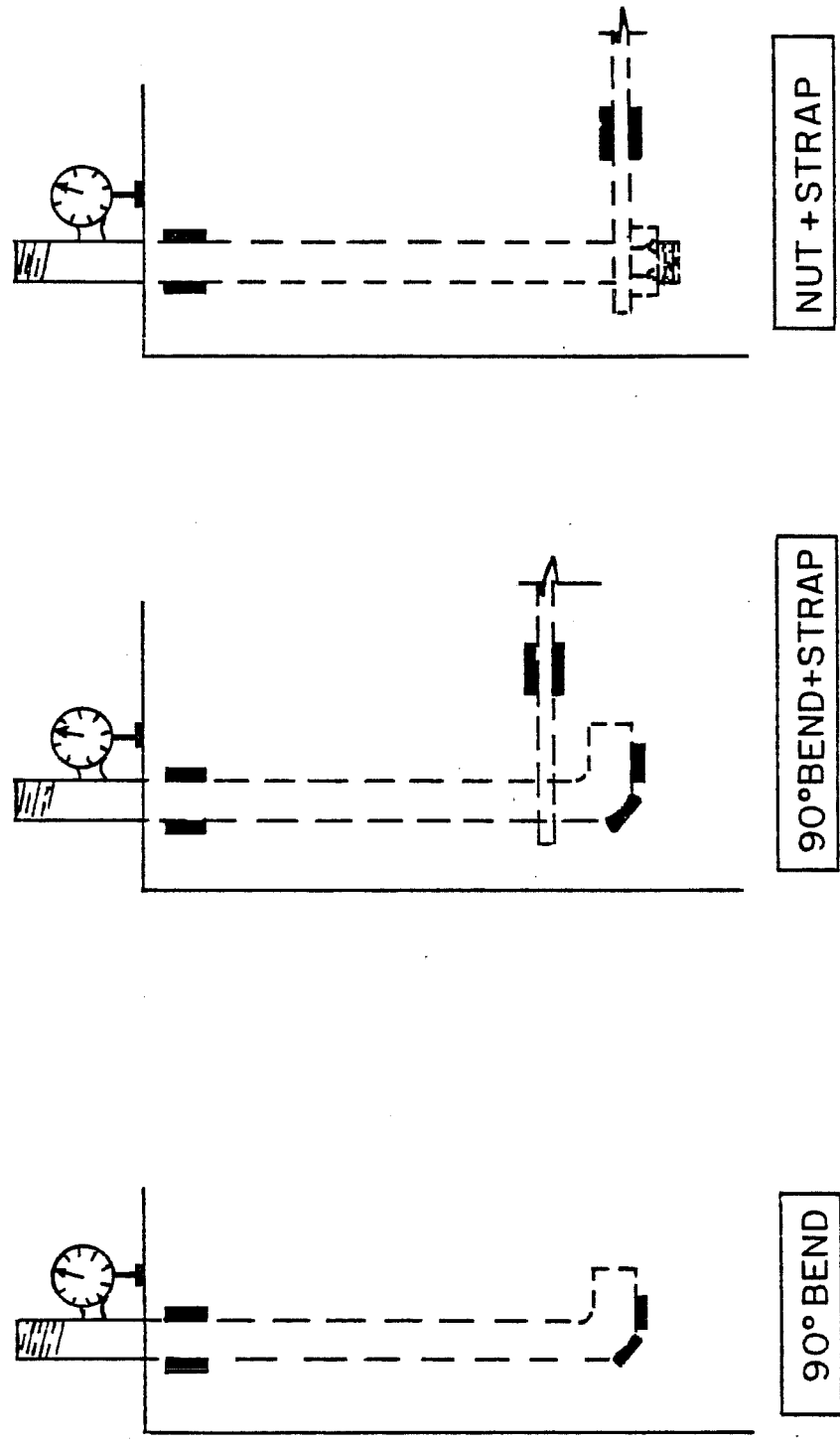

■ STRAIN GAGE ⊙ DIAL SLIP MEASUREMENT

Fig. 7.6 Bolt instrumentation

Bolt Tension vs. Lead Slip Anchorage - 90° bend

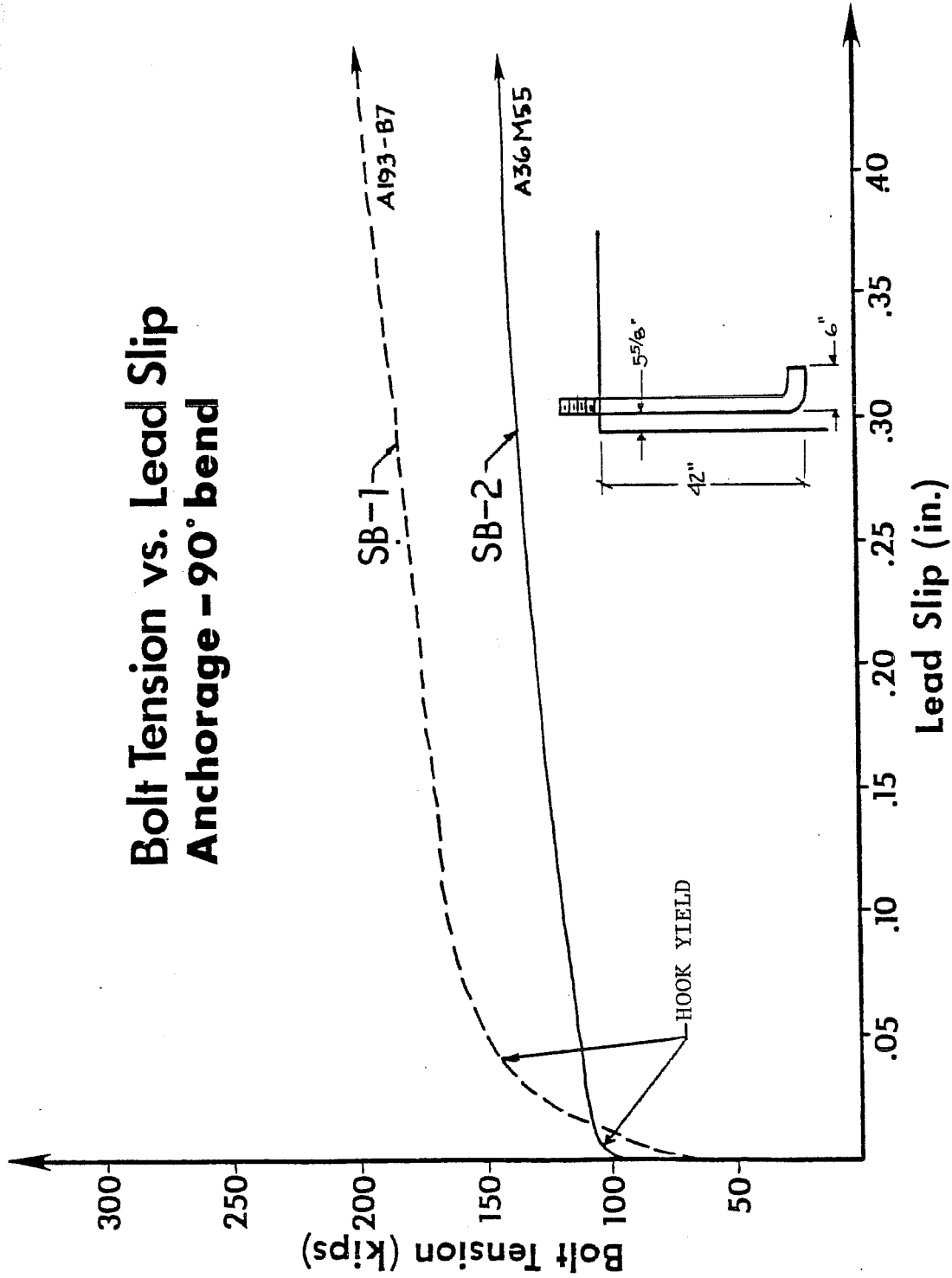

Fig. 7.7 Load-slip curves for tests SB1 and SB2

Bolt Tension vs. Lead Slip Anchorage - 90° bend + strap

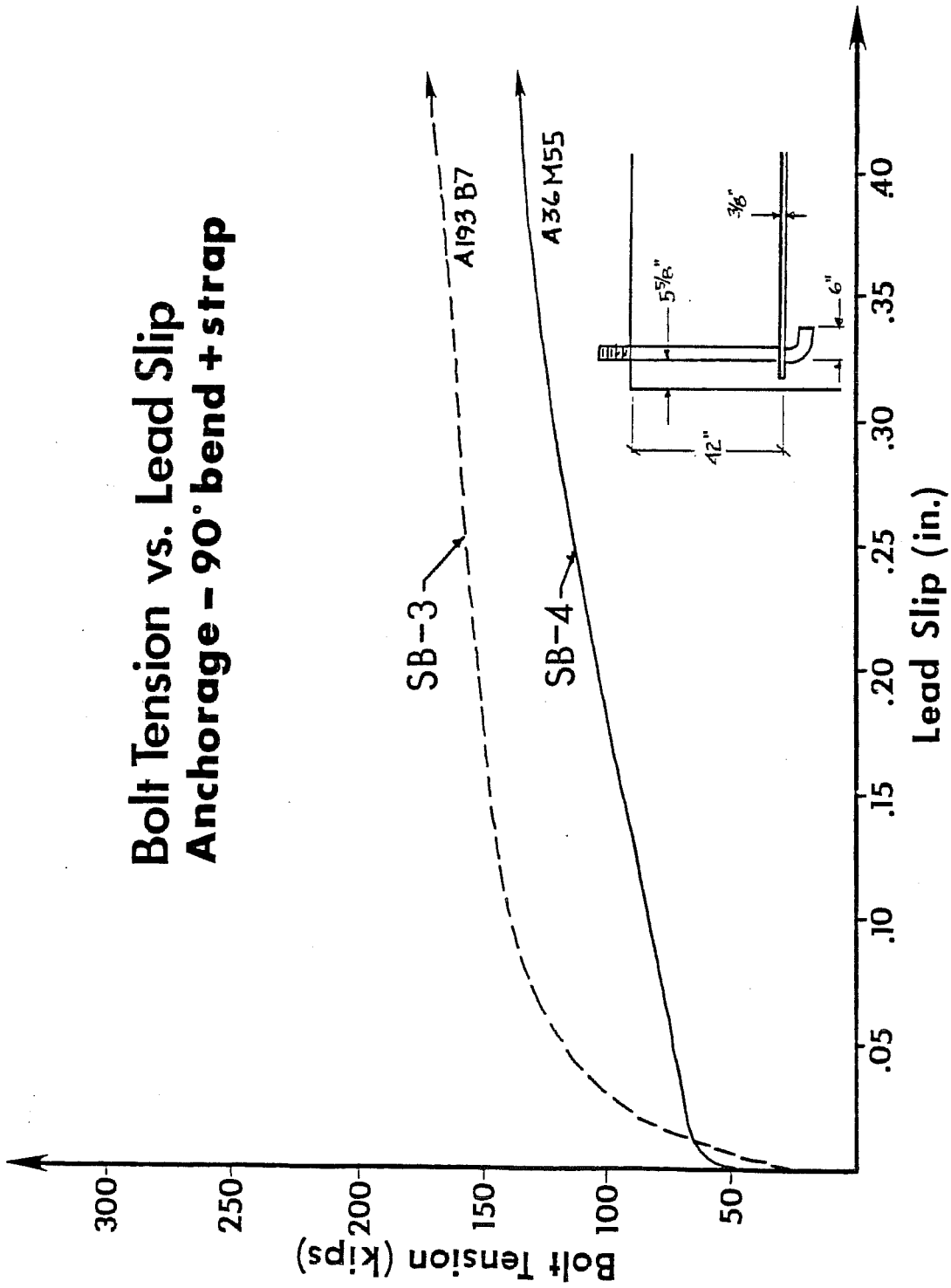

Fig. 7.8 Load-slip curves for tests SB3 and SB4

Bolt Tension vs. Lead Slip Anchorage - nut + strap

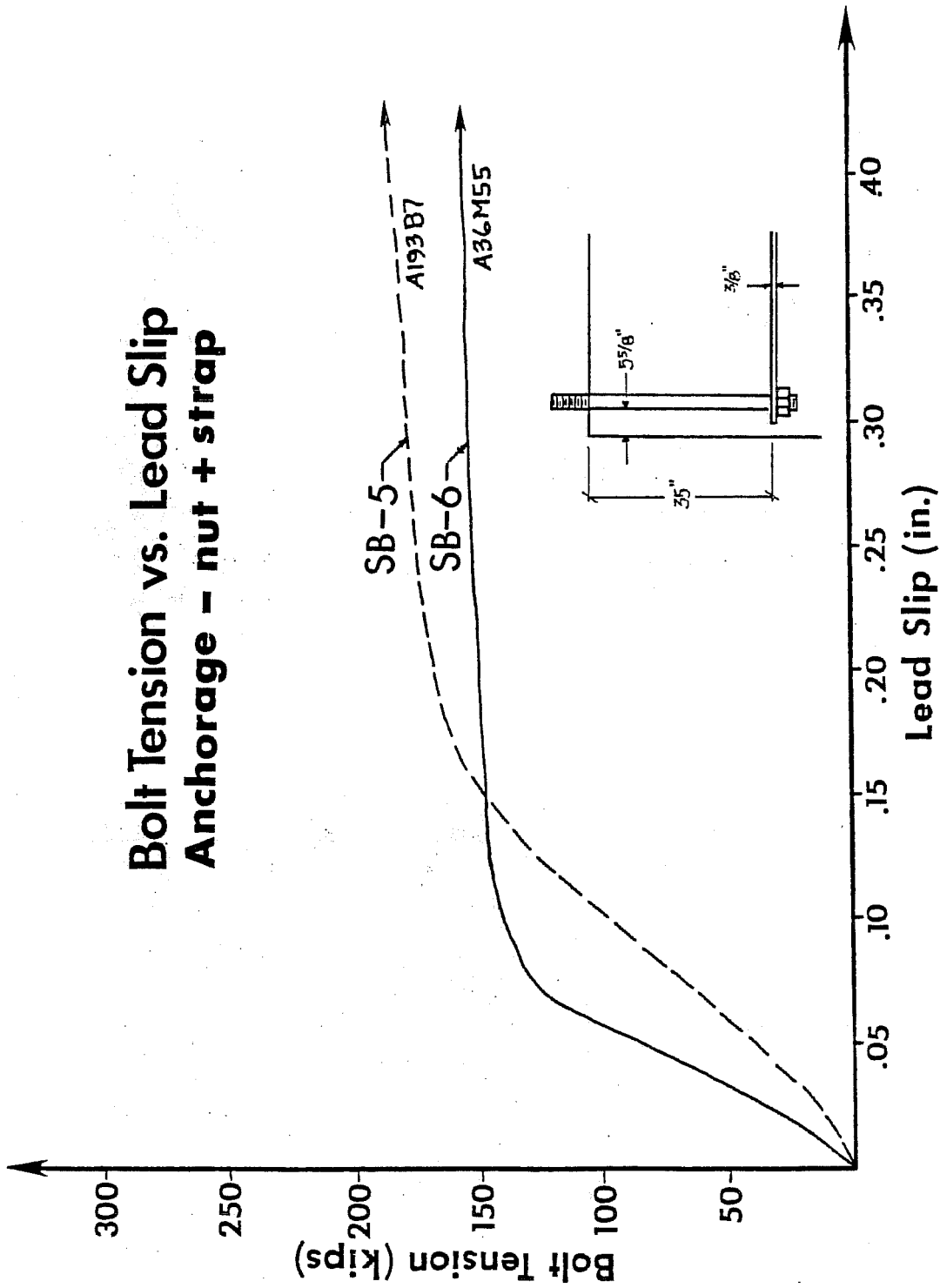

Fig. 7.9 Load-slip curves for tests SB5 and SB6

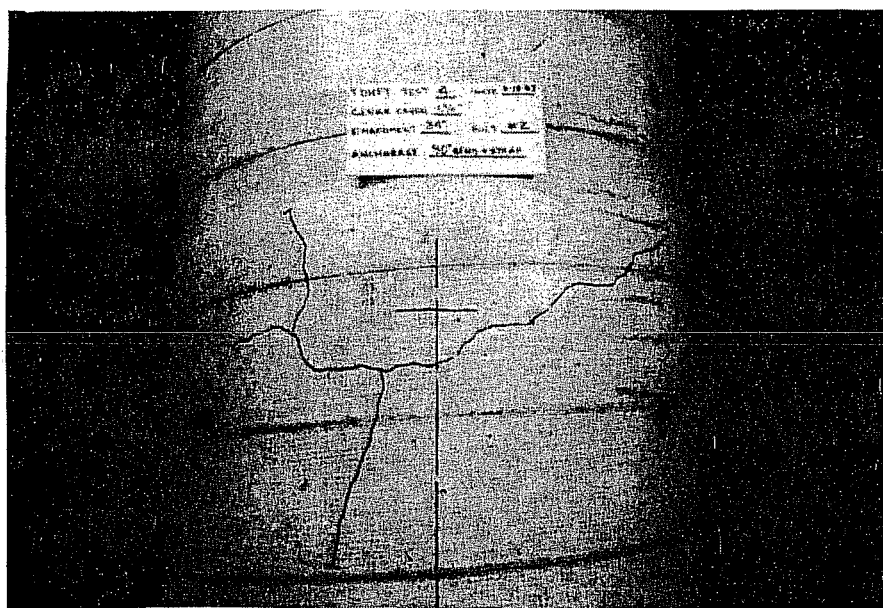

Fig. 7.10 Crack pattern of test SB3

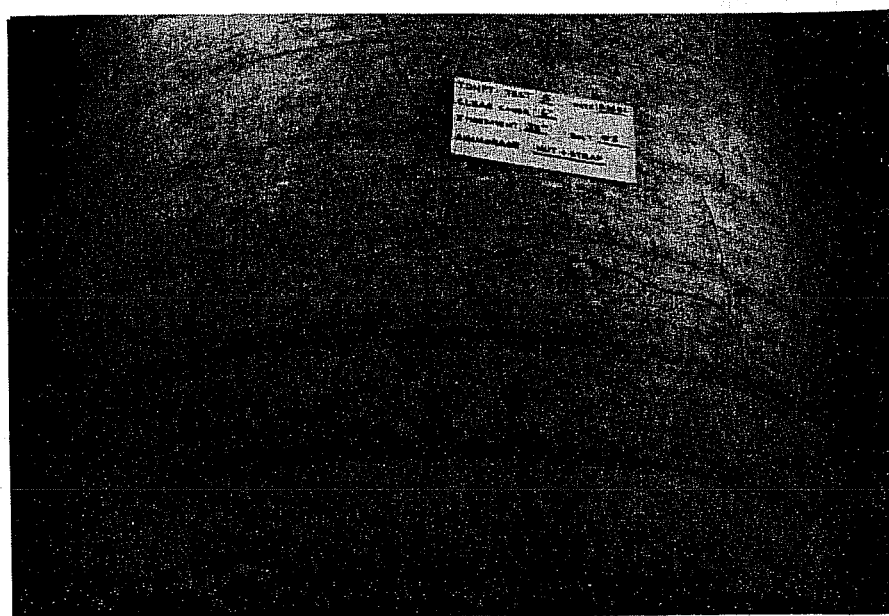

Fig. 7.11 Crack pattern of test SB5

The last two single bolt tests, SB-5 and SB-6, consisted of bolts having nut and strap anchorages. More extensive surface cracking was observed, as seen in Fig. 7.11. With a nut and strap, a crushed concrete cone formed at the anchorage and allowed the bolt to reach a higher stress.

The two-bolt group, test TB-1, consisting of a circular steel plate and nut anchorage system, exhibited crack propagation (Fig. 7.12) similar to previous two-bolt tests with small spacing.

7.4 Analysis of Results

7.4.1 Anchorage Type. For each single bolt test having similar bolt materials, the load-slip responses for the three types of anchorages are plotted in Figs. 7.13 and 7.14. The nut and strap anchorage was most effective in allowing the bolt to reach a higher level of stress. Contrary to expectations, the 90° bend acting alone proved slightly more effective than the 90° bend plus strap. Longitudinal stress in the steel straps remained relatively low during loading, indicating that the strap acts as a bearing plate against the concrete rather than a restraining device against cover splitting.

7.4.2 Bolt Material. Figures 7.13 and 7.14 also illustrate the effect of grade of steel on the performance of the bolt. Anchorages fabricated from A36M steel reached stresses above 55 ksi, while those made from A193 material did not reach 105 ksi.

It is evident that a portion of the 105 ksi bar strength is "wasted," that is, the bolt never reaches yield stress. Consideration should be given to using a larger bolt size or a greater number of lower strength bolts instead of the high strength bolts. The major consideration in such a decision is the relative cost of the two bolt materials and the fabrication and installation costs of the anchor bolt assembly.

7.4.3 Calculated Strength. In the single bolt tests, three anchorage types and two bolt materials were used. Failure of the tests with 90° bends and 90° plus steel straps was by yielding of the bend or yielding of the bolt material. Equation 6 is for wedge-splitting failures and, therefore, cannot be applied to these installations.

Text SB-5 was a high strength bolt with a nut/strap anchorage, while test TB had high strength bolts anchored in a circular steel plate. Figure 7.15 shows the anchorages for each of these tests. For computing bolt strength, an effective bearing area was used. In Eq. 6, the bearing plate thickness must be at least 1/8 of the diameter of bearing plate. With a 3/8 in. plate, the effective bearing area is

$$\pi/4[(8t)^2 + D^2] = 4.6 \text{ in.}^2$$

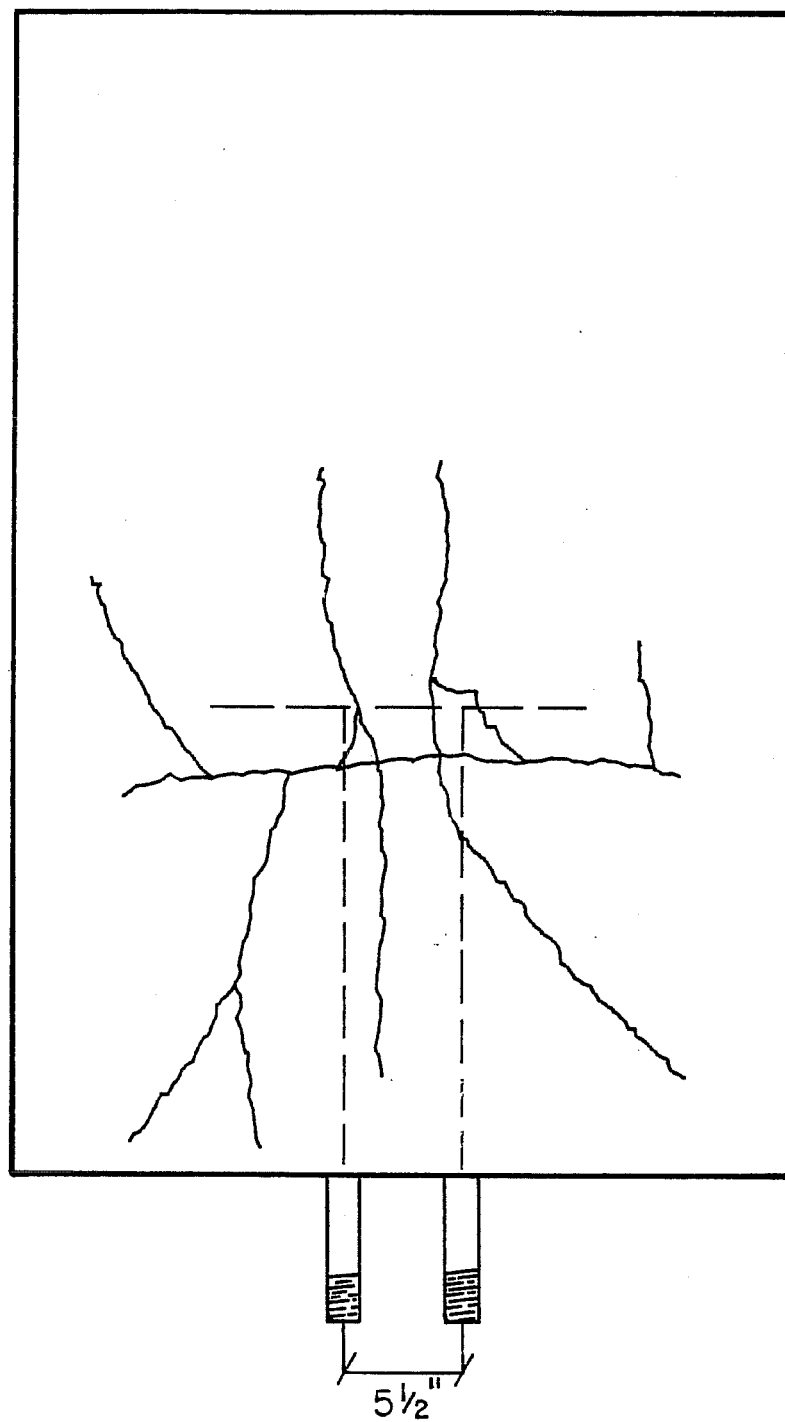

Fig. 7.12 Crack pattern of test TBI

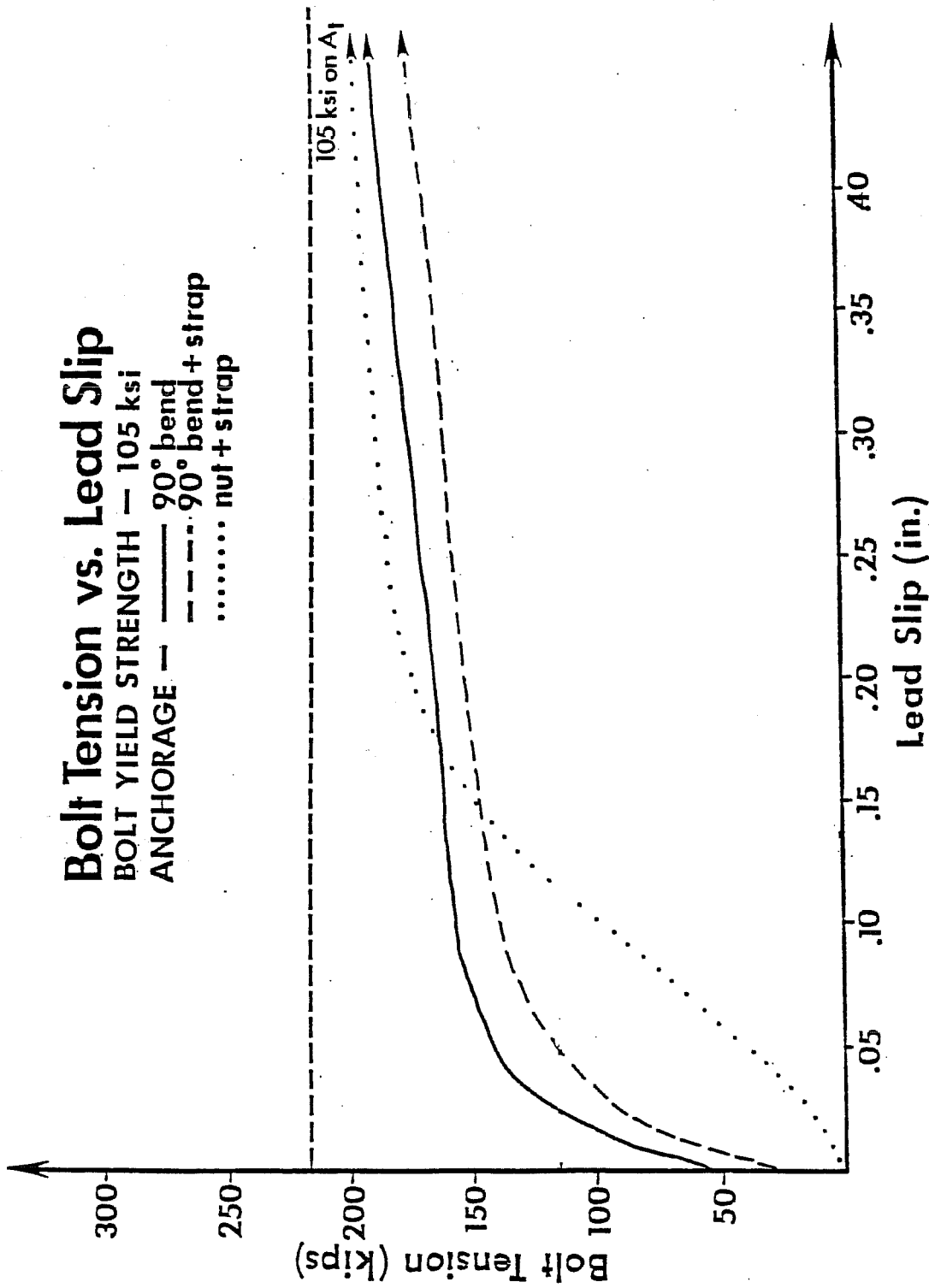

Fig. 7.13 Load-slip curves for tests SB1, SB3 and SB5

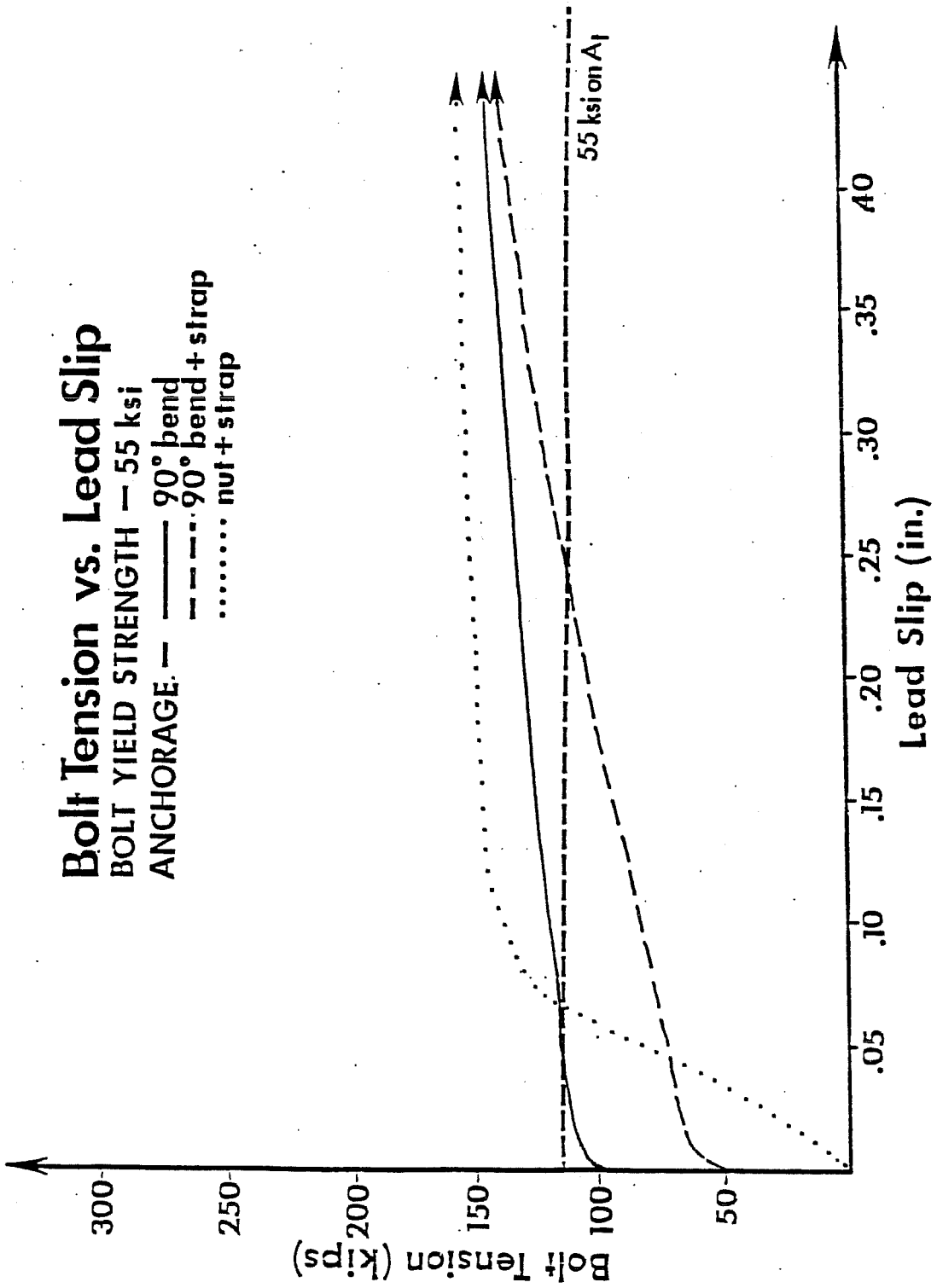
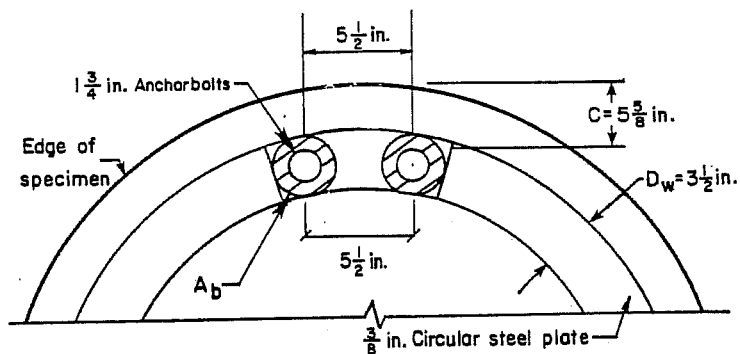
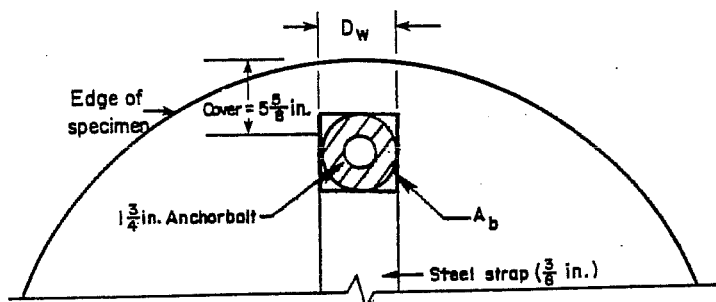

Fig. 7.14 Load-slip curves for tests SB2, SB4 and SB6



Test TB-1



Test SB-5

Fig. 7.15 Effective bearing area, tests TB-1 and SB-5

Table 7.2 Effective bearing area for tests SB-5 and TB-1

Test	f'_c (psi)	C (in.)	D_w	$D_w - D$ (in.)	S (in.)	T_{test} (kips)	Eff. A_b (in. ²)	T_i Eq. 6	$\frac{T_{test}}{T_i}$
SB-5	3540	5-5/8	3.5	1.75	---	179	7.2	154	1.16
			3.0*	1.25	---	179	4.6	111	1.60
TB	3540	5-5/8	3.5	1.75	5.5	144	7.2	78	1.85
			3.0*	1.25	5.5	144	4.6	56	2.57

* $D_w = 8 t = 3$ in.

Using a bearing area which is the largest inscribed circle, the bearing area is $\pi/4(3.5^2 - D^2) = 7.2 \text{ in.}^2$

It is assumed that the bearing area of the anchorage is a finite, well-defined area. In tests SB-5 and TB, only a portion of the steel plate is effective in bearing. It can be seen that the bolt capacity is conservatively estimated using the effective bearing area based on the thickness limitation of $D_w/8$. In the case of the two-bolt group (TB), the reduction for group effect may not be necessary where a single plate is used for anchorage of several bolts.

Figure 7.16 illustrates the behavior of the bolts with 90° bends under the action of tensile loads. During loading, the critical section at the start of the 90° bend is subjected to bending and axial tension. As the load increases, the concrete on the inside of the 90° bend begins to crush and consolidate. As crushing continues, the bend deforms and assumes the position indicated by the dashed lines in Fig. 7.16. A void is created along the outer edge of the bend. Additionally, crushing of the concrete in the tail region of the bend is possible due to deformation of the 90° hook. Because of this deformation a very complex stress situation exists in the anchorage and it is unlikely that Eq. 6 can be applied because the effective bearing area A_b is not well-defined.

7.5 Post-tension Test

Prior to testing the two-bolt group, test TB, the bolts were grouted at the concrete face and post-tensioned to investigate bolt stress induction and creep relaxation losses. Details of the bolt group/grout layer are shown in Fig. 7.17a. A 2 in. steel plate was positioned over the bolt group and a 3 in. thick layer of high strength grout was placed under the plate. The nuts were snugged tight and then rotated at 60 degree increments to a total rotation of 480 degrees. Figure 7.17b shows the snugging of the nut with a standard wrench and Fig. 7.17c shows tightening the nuts with a pneumatic impact wrench. At the end of each increment of rotation the strain gages at the lead end of the bolts were read.

The results of this test are presented in Fig. 7.18. A target load range based on 17.2 sq. in. bearing area and 300 degrees of rotation is shown as 68 ± 5 ksi on the gross area of the bolts. The calculated values in this figure are values currently used in the SDHPT Specification. The test curve represents the tension induced in the bolt as a function of nut rotation. Tension in the bolt group was maintained for 23 hours during which time the strain gages were read at 1-, 7-, 10-, and 1380-minute stages. The resulting bolt tension versus time relationship is shown as an extension of the test curve.

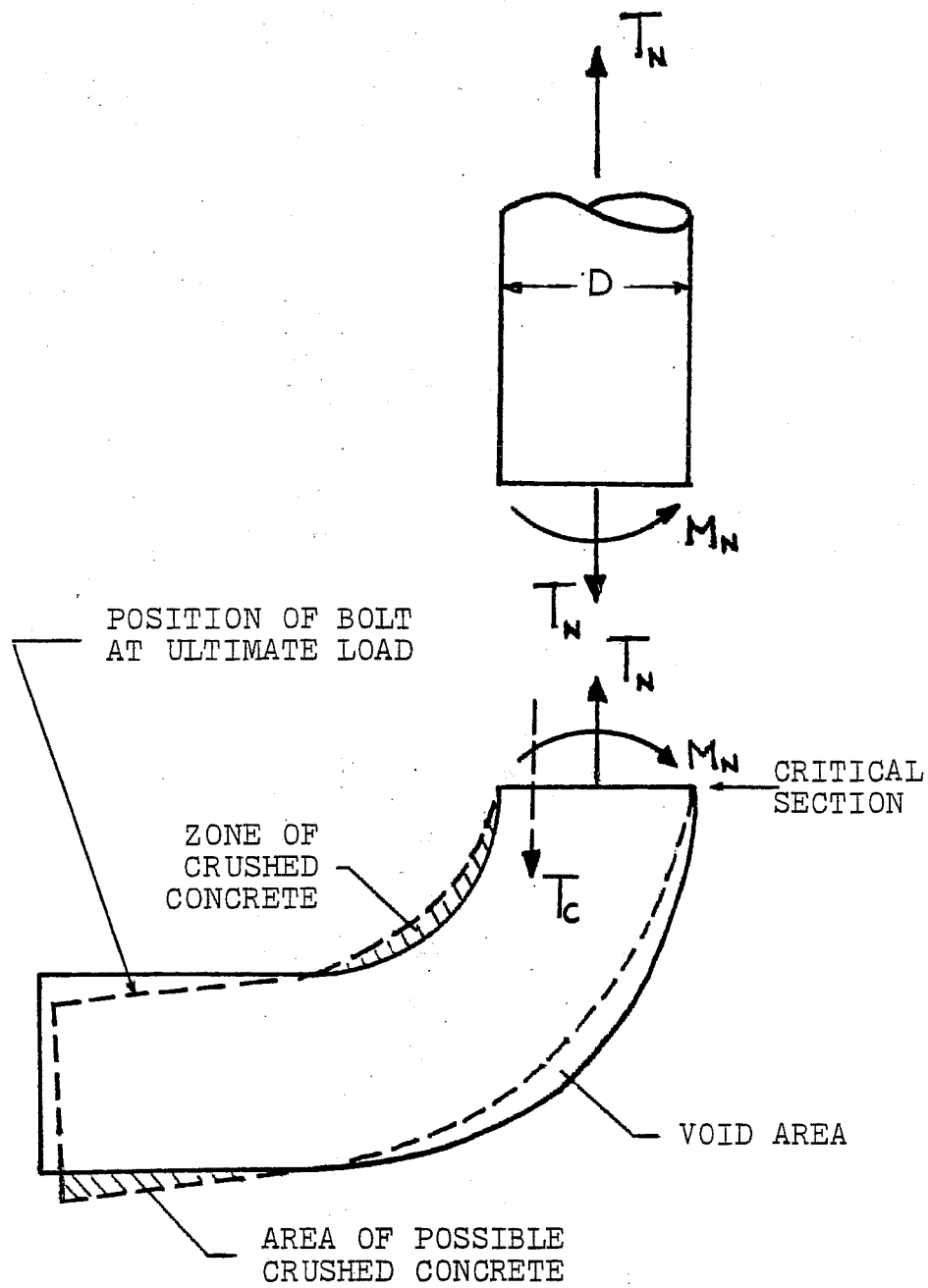
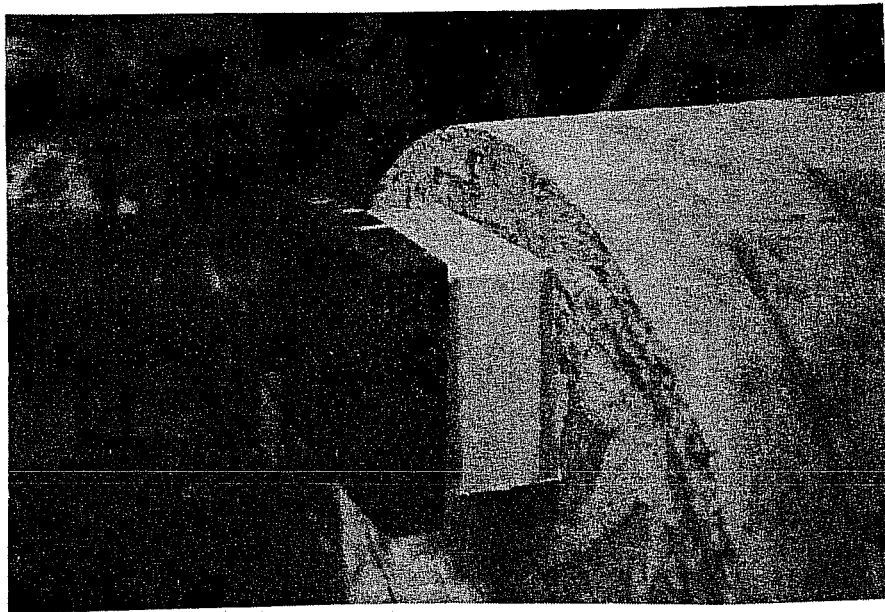
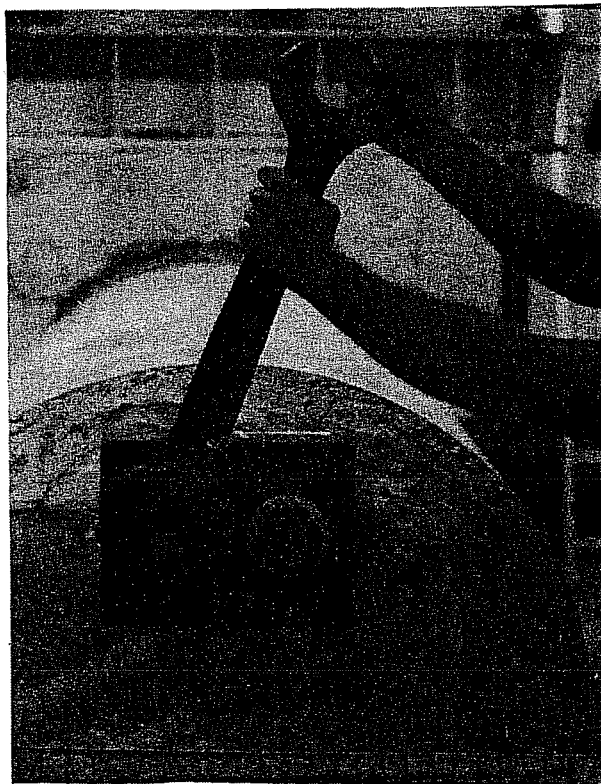

Fig. 7.16 Behavior of 90-degree bend



(a) Plate and grout



(b) Snugging nuts with standard wrench

Fig. 7.17 Post-tensioning test

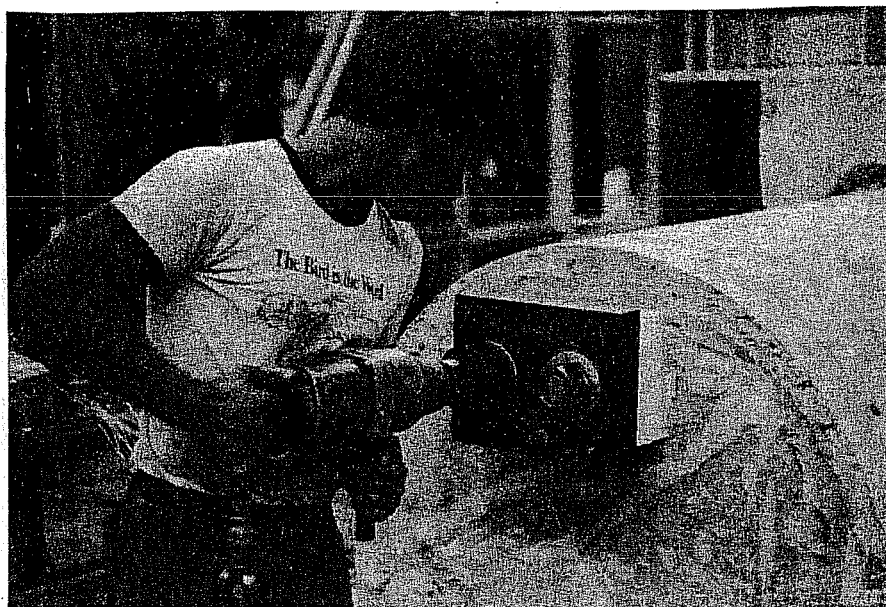

(c) Tightening with pneumatic wrench

Fig. 7.17 (Continued)

POST TENSION TEST

1 3/4" 8UN A193-B7 Bolts

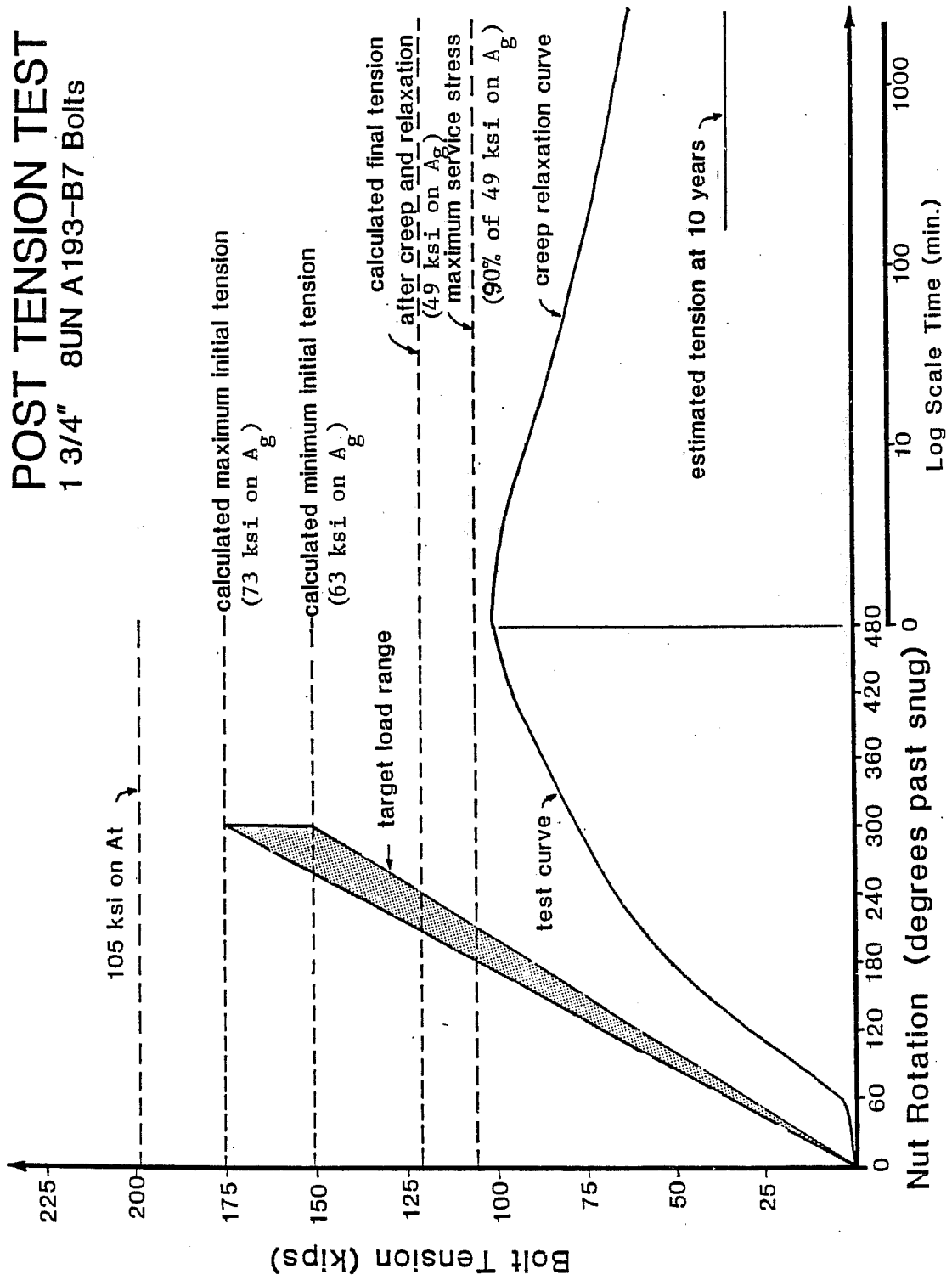

Fig. 7.18 Results of post-tension test

It is evident that the induced bolt stress did not reach the target load range. This has been attributed to possible compression of the washer, initial tightening of the nut, slip of the anchorage device, or a combination of the above.

The initial 60 degrees of rotation produced very little bolt tension. This is probably due to "slack" in the washer/nut/plate region. Prior to rotation of the nut with an impact wrench, the nut was "snugged" by using a standard cast iron wrench. It is clear that a more accurate definition of "snug" is required.

Since the maximum service stress level is greater than the applied bolt tension, the possibility of significant stress variation still exists, even though post-tensioning is intended to eliminate the problem.

CHAPTER 8

SUMMARY AND CONCLUSIONS

8.1 Summary

Bolt-Group Tests. In this study, the strength and behavior of high strength anchor bolt groups embedded in reinforced concrete piers was investigated. Fourteen 4-bolt groups embedded in circular piers were tested. Nine tests were conducted with 2-bolt groups in circular piers. Four tests on three-bolt groups in square piers were conducted. Bolts with a 1-3/4 in. diameter and a yield stress of 105 ksi were used. The anchorage length was 20 bar diameters and a nut and two or three standard washers provided bearing at the end.

The main objective of this series of tests was to determine the effects of bolt spacing and clear cover on the strength of the anchor bolt groups. Center-to-center bolt spacing ranged from 4.0 in. to 13.5 in.; clear cover ranged from 2.4 in. to 7.4 in. Bolt groups were compared in terms of normalized bolt tension versus bolt slip curves. In general, it was confirmed that as bolt spacing, clear cover, or the combination of both is increased, the group capacity is also increased. Also, groups with shallow clear cover failed very abruptly, while groups with large cover underwent a significant amount of slip while maintaining their load capacity before and after ultimate was reached.

Single Bolt Tests. Six single bolt tests were performed. The clear concrete cover to each bolt was maintained at 5-5/8 in. Two different steel grades were used in manufacturing the bolts (55 and 105 ksi). Anchorage for the bolts consisted of a 90° bend in the bolt, a 90° bend plus steel strap, or a nut and steel strap combination. The objectives of this series of tests were to determine the effects of the bolt material and the type of anchorage on the tensile strength of the installations. Bolts with 55 ksi yield strength reached stresses greater than yield while bolts with yield strengths of 105 ksi did not reach yield. The nut/strap anchorage proved to be the most effective of the three, while anchorages consisting of 90° bends and 90° bends plus straps performed similarly but less effectively than the nut/strap anchorage.

A post-tension test was performed on a two-bolt group as part of the single bolt test series. The stress induced in the bolts, resulting from a specified rotation of the nut, fell below expected values. A relatively slow buildup of stress at the early stages of post-tensioning indicated a general lack of tightness in the nut/washer/plate region after snugging

8.2 Conclusions

Bolt-Group Strength. The bolt group interaction and strength reduction were evaluated by comparing the average test capacity with the predicted capacity of an isolated bolt with similar geometry. It was observed that as bolt spacing decreased, the reduction in strength significantly increased. From a least squares analysis of the available data, the following modification to Hasselwander's [1] equation was produced for the nominal tensile capacity of an anchor bolt in a bolt group based on failure of the concrete:

$$T_n = 140 A_b \sqrt{f'_c} [0.7 + \ln(2C/(D_w - D))](0.02S + 0.4) \quad (\text{Eq. 6})$$

where A_b is the net bearing area (in.²), D and D_w are the bolt and washer diameter (in.), C is the clear cover (in.), and S is the bolt spacing (in.), with $(0.02S + 0.40) \leq 1.0$. Net bearing area is gross area of anchor plate or washer less the bolt area but not more than $4D^2$ nor less than the projecting area of the nut. For anchor plates or washers used in addition to the nut, the effective diameter of the washer D_w shall not be taken greater than 8 times the washer or anchor plate thickness. Where a continuous plate or template is used, the diameter D_w may be taken as the diameter of a circle concentric with the bolt and inscribed within the template or anchor plate. Equation 6 provides an estimate of the strength of closely spaced anchor bolts with edge cover typical of highway-related structures. The design tensile capacity, T_u , can be determined as:

$$T_u = \phi T_n$$

where ϕ is a capacity reduction factor of 0.75. To ensure ductility and prevent failure of the concrete due to overload:

$$\phi T_n \geq A_{sm} f_y$$

where A_{sm} is the meantensile area of the anchor bolt and f_y is the yield strength of the bolt material.

From observations of the tests and examination of calibrated strength, several conclusions can be drawn: (1) a significant percentage of existing highway anchor bolt installations probably do not have sufficient cover to provide any ductility in case of overload. Ductility is developed only if the transverse reinforcement is located some distance outside the bolt location, probably around two times the bolt diameter. (2) Designing piers with enough cover to yield large diameter high strength bolts ($f_y = 105$ ksi) would probably be uneconomical, and (3) designing piers to develop large diameter bolts of lower strength material or high strength small diameter bolts might prove to be more practical.

Single Bolt Tests. In the single bolt test series, the effectiveness of three different anchorage types was examined. A nut/steel strap anchorage proved most effective in developing strength. The 90° bends indicated that the bolt yields in flexure at the bend. As a result, localized crushing occurs at the bend and the bend gradually "straightens" as load or deformation is increased. The cones of concrete seen in anchorages with nuts and washers are not developed in the hooked bars.

REFERENCES

1. Hasselwander, G. B., Jirsa, J. O., Breen, J. E., and Lo, K., "Strength and Behavior of Anchor Bolts Embedded Near Edges of Concrete Piers," Research Report 29-2F, Center for Highway Research, The University of Texas at Austin, May 1977.
2. Cannon, R. W., Burdette, E. G., and Funk, R. R., "Anchorage to Concrete," Research and Development Report No. CEB 75-32, Civil Engineering Branch, Tennessee Valley Authority, Knoxville, December 1976.
3. ACI Committee 349, "Proposed Addition to: Code Requirements for Nuclear Safety Related Concrete Structures," Journal of the American Concrete Institute, August 1978.
4. Breen, J. E., "Development Length for Anchor Bolts," Research Report 55-1F, Center for Highway Research, The University of Texas at Austin, April 1964.
5. Lee, D. W., and Breen, J. E., "Factors Affecting Anchor Bolt Development," Research Report 88-1F, Center for Highway Research, The University of Texas at Austin, August 1966.
6. Swirsky, R. A., Dusel, J. P., Crozier, W. F., Stoker, J. R., and Nordlin, E. F., "Lateral Resistance of Anchor Bolts Installed in Concrete," Report FHWA-CA-ST-4167-77-12, California Department of Transportation, Sacramento, May 1977.
7. Klingner, R. E., and Mendonca, J. A., "Tensile Capacity of Short Anchor Bolts and Welded Studs: A Literature Review," unpublished research report, The University of Texas at Austin, June 1981.
8. Klingner, R. E., and Mendonca, J. A., "Shear Capacity of Short Anchor Bolts and Welded Studs: A Literature Review," unpublished research report, The University of Texas at Austin, June 1981.
9. Cichy, N. T., "Influence of Spacing and Concrete Edge Cover on the Strength of Anchor Bolt Groups," unpublished M.S. report, The University of Texas at Austin, May 1982.
10. Calzadilla, M. R., "Tensile Capacity of High-Strength Anchor Bolt Groups Embedded in Circular Concrete Piers," unpublished M.S. thesis, The University of Texas at Austin, December 1982.
11. Smart, W. H., "Strength and Behavior of Anchor Bolt Groups in Reinforced Concrete Piers," unpublished M.S. thesis, The University of Texas at Austin, May 1983.

12. Pavluvcik, M. P., "Strength and Behavior of Typical Anchor Bolt Installations in Highway Applications," unpublished M.S. thesis, The University of Texas at Austin, December 1983.
13. Texas Highway Department, "Standard Specifications for Construction of Highways, Streets, and Bridges," 1972 Edition.
14. American Society for Testing Materials, "Alloy Steel and Stainless Steel Bolting Materials for High-Temperature Services," ASTM A193-74.